

# Sensors, cables and accessories

## Catalog



**Legal notices**

Both this catalog and the product it describes are copyrighted. All rights belong to the publisher. The catalog may not be copied, reproduced, translated or made accessible to a third party in any form, neither in its entirety nor as an excerpt.

No liability may be claimed against the publisher regarding the product described in this catalog. The publisher assumes no liability for accuracy of the catalog contents. Furthermore, under no circumstances may the publisher be held liable for direct or indirect damage of any kind resulting from use of the product or the catalog, even if the publisher has expressly indicated the potential for occurrence of such damage.

The publisher assumes no liability for any product defects. This warranty and liability limitation applies to all distributors and sales partners as well.

The trademarks mentioned in this catalog are generally noted as such and are the property of their owners. Lack of such designation does not imply, however, that names are not protected by trademark laws.

©PRÜFTECHNIK Condition Monitoring; all rights reserved

**Contents and chapter overview** **C**

**Sensors for permanent installation** **1**

**Sensors for mobile data collection** **2**

**Mounting adapters and tools** **3**

**Cables, interfaces and accessories for permanent installation** **4**

**Sensor cables and connection adapters for mobile data collectors** **5**

**Communication cables** **6**

**Appendix** **A**



## C

## Contents

1

Order no. Product description Page

## Chapter 1

## Sensors for permanent installation

2

VIB 6.102 R : Industrial accelerometer for standard machinery, adhesive mount ..... 20

VIB 6.122 R : Industrial accelerometer for standard machinery, M8 thread mount ..... 20

VIB 6.132 R : Industrial accelerometer for standard machinery, UNC 5/16 thread mount ..... 20

3

VIB 6.125 R : Industrial accelerometer for standard machinery, M8 thread mount, high-temperature version..... 20

VIB 6.135 R : Industrial accelerometer for standard machinery, UNC 5/16 thread mount, high-temperature version..... 20

VIB 6.107 : Industrial accelerometer for low-speed machinery, adhesive mount..... 22

VIB 6.127 : Industrial accelerometer for low-speed machinery, M8 thread mount..... 22

4

VIB 6.137 : Industrial accelerometer for low-speed machinery, UNC 5/16 thread mount..... 22

VIB 6.125 RIP : Industrial accelerometer for standard machinery ( $n > 60 \text{ min}^{-1}$ ) ..... 24VIB 6.125 IDEX : Industrial accelerometer for standard machinery ( $n > 60 \text{ min}^{-1}$ ), intrinsically safe ..... 24VIB 6.129 IP : Industrial accelerometer for low-speed machinery ( $n > 20 \text{ min}^{-1}$ ) ..... 24

5

VIB 6.129 IDEX : Industrial accelerometer for low-speed machinery ( $n > 20 \text{ min}^{-1}$ ), intrinsically safe ..... 24

VIB 6.202-3: Mini accelerometer with RG 174 cable, 3 meters ..... 26

VIB 6.202-6: Mini accelerometer with RG 174 cable, 6 meters ..... 26

VIB 6.203-3: Mini accelerometer with Spec 44 cable, 3 meters..... 26

VIB 6.203-6: Mini accelerometer with Spec 44 cable, 6 meters..... 26

6

VIB 6.215: Hybrid triaxial accelerometer for VIBGUARD 1 Hz ... 10 kHz (Z) ..... 30

VIB 6.216: Hybrid triaxial accelerometer for VIBGUARD 0.1 Hz ... 10 kHz (Z) ..... 30

VIB 5.731 : VIBROTECTOR vibration transmitter, 10 Hz - 1 kHz ..... 32

VIB 5.736 : VIBROTECTOR vibration transmitter, 2 Hz - 1 kHz ..... 32

VIB 6.172 : ICP-type accelerometer for very low-speed machinery 0.1 Hz - 10 kHz, Mil connector..... 34

VIB 6.195 : CLD accelerometer for very low-speed machinery 0.1 Hz - 10 kHz, Mil connector ..... 34

A

VIB 6.102 DEX : Industrial accelerometer for standard machinery, adhesive mount, intrinsically safe ..... 36

VIB 6.122 DEX : Industrial accelerometer for standard machinery, M8 thread mount, intrinsically safe ..... 36

VIB 6.132 DEX : Industrial accelerometer for standard machinery, UNC 5/16 thread mount, intrinsically safe ..... 36

VIB 6.107 DEX : Industrial accelerometer for low-speed machinery, adhesive mount, intrinsically safe..... 40

VIB 6.127 DEX : Industrial accelerometer for low-speed machinery, M8 thread mount, intrinsically safe..... 40

VIB 6.137 DEX : Industrial accelerometer for low-speed machinery, UNC 5/16 thread mount, intrinsically safe..... 40

VIB 6.202-6XD: Mini accelerometer with RG 174 cable, 6 meters, intrinsically safe ..... 42

VIB 6.202-10XD: Mini accelerometer with RG 174 cable, 10 meters, intrinsically safe ..... 42

VIB 6.203-3XD: Mini accelerometer with Spec 44 cable, 3 meters, intrinsically safe..... 42

VIB 6.203-6XD: Mini accelerometer with Spec 44 cable, 6 meters, intrinsically safe..... 42

VIB 5.731 EX : VIBROTECTOR vibration transmitter, 10 Hz - 1 kHz, intrinsically safe ..... 44

VIB 5.736 EX : VIBROTECTOR vibration transmitter, 2 Hz - 1 kHz, intrinsically safe ..... 44

VIB 6.172 XICP: ICP-type accelerometer for very low-speed machinery ( $n > 6 \text{ min}^{-1}$ ), intrinsically safe ..... 46

VIB 5.991-DIS: Inductive displacement sensor ..... 48

VIB 5.992-NX: Inductive RPM sensor for wind power plants incl. cable ..... 49

VIB 5.992-STD: Default RPM sensor for Online CMS, incl. cable ..... 50

VIB 6.610: Temperature probe PT100 for permanent mounting ..... 51

VIB 6.620 SET : Inductive RPM sensor for VIBRONET Signalmaster incl. connector; ( $f < 300 \text{ Hz}$ ) ..... 52VIB 6.620 : Inductive RPM sensor for VIBRONET Signalmaster w/o connector; ( $f < 300 \text{ Hz}$ )..... 52

VIB 6.621 : Connector for sensor VIB 6.620..... 52

VIB 6.622 SET : Inductive RPM sensor for VIBRONET Signalmaster incl. connector; ( $f < 1500 \text{ Hz}$ ) ..... 53VIB 6.622 : Inductive RPM sensor for VIBRONET Signalmaster w/o connector; ( $f < 1500 \text{ Hz}$ )..... 53

VIB 6.621 : Connector for sensor VIB 6.622..... 53

VIB 6.641: Proximity sensor for Online CMS incl. cable (3-15 mm) ..... 54

VIB 6.645 SET: Displacement sensor for Online CMS incl. cable (2-10 mm)..... 55

VIB 5.993-MIC: Measuring microphone , CL 1 (DIN EN 60 651)..... 56

VIB 6.411 SET: WEARSCANNER set with switching output ..... 58

VIB 8.170: Online VIEW 4.0 for up to 100 data points ..... 60

VIB 8.171: Online VIEW 4.0 for up to 250 data points ..... 60

VIB 8.172: Online VIEW 4.0 for up to 500 data points ..... 60

VIB 8.173: Online VIEW 4.0 for up to 1000 data points ..... 60

## Contents

Order no. Product description Page

### Chapter 2

#### Sensors for mobile data collection

VIB 8.660 VS :	VIBCODE transducer for VIBSCANNER and VIBXPERT.....	64
VIB 8.660 VD :	VIBCODE transducer for VIBROTIP .....	64
VIB 8.660 XVS :	VIBCODE transducer with intrinsic safety for VIBSCANNER EX and VIBXPERT EX .....	66
VIB 8.660 XVD :	VIBCODE transducer with intrinsic safety for VIBROTIP EX and VIBTOOL.....	66
VIB 6.142 R:	Mobile industrial accelerometer for standard machinery (n > 600 min <sup>-1</sup> ).....	68
VIB 6.147:	Mobile industrial accelerometer for low-speed machinery (n > 120 min <sup>-1</sup> ) .....	69
VIB 6.142 DEX:	Mobile industrial accelerometer for standard machinery (n > 600 min <sup>-1</sup> ), intrinsically safe.....	70
VIB 6.147 DEX:	Mobile industrial accelerometer for low-speed machinery (n > 120 min <sup>-1</sup> ), intrinsically safe .....	72
VIB 6.162 VD :	Dual sensor for vibration and temperature measurement with VIBSCANNER EX / VIBXPERT EX .....	74
VIB 6.162 VT :	Dual sensor for vibration and temperature measurement with VIBTOOL.....	74
VIB 8.606 VS :	TIPTECTOR handheld probe set for VIBSCANNER and VIBXPERT.....	76
VIB 8.606 VD :	TIPTECTOR handheld probe set for VIBROTIP .....	76
VIB 8.606 XVS :	TIPTECTOR handheld probe set for VIBSCANNER EX, intrinsically safe .....	78
VIB 8.606 XVD :	TIPTECTOR handheld probe set for VIBROTIP EX, intrinsically safe .....	78
VIB 8.666 VS :	Mobile accelerometer with quick fitting coupling for VIBSCANNER and VIBXPERT .....	80
VIB 8.666 VD :	Mobile accelerometer with quick fitting coupling for VIBROTIP .....	80
VIB 6.655 :	Triaxial accelerometer for VIBXPERT .....	81
VIB 8.605 :	Built-in temperature probe for VIBROTIP / VIBSCANNER (spare part).....	82
VIB 8.607-1,5 :	Temperature probe with magnetic holder, 1.5 m.....	82
VIB 8.608 :	Handheld temperature probe.....	82
VIB 6.631 :	Laser trigger / Laser RPM sensor.....	84
VIB 6.631 EX:	Laser trigger / Laser RPM sensor, intrinsically safe .....	86
VIB 6.640:	Inductive proximity sensor for VIBXPERT incl. cable (3-15 mm) .....	88
VIB 6.672:	LED stroboscope .....	89
VIB 6.673:	Current clamp (400A AC/ 600A DC).....	90

### Chapter 3

#### Mounting adapters and tools

VIB 3.411 :	Screwed adapter with locking nut, M8 to M8.....	93
VIB 3.412 :	Screwed adapter with locking nut, M8 to M10.....	93
VIB 3.413 :	Screwed adapter with locking nut, M8 to M12 .....	93
VIB 3.414 :	Screwed adapter with locking nut, UNC 5/16 to UNC 5/16.....	93
VIB 3.415 :	Screwed adapter with locking nut, UNC 5/16 to UNC 3/8 - 16.....	93
VIB 3.416 :	Screwed adapter with locking nut, UNC 5/16 to UNC 1/2 -13 .....	93
VIB 3.417-M5 :	Screwed adapter for mini accelerometer, UNF 1/4 to M5-flat .....	94
VIB 3.417-M6 :	Screwed adapter for mini accelerometer, UNF 1/4 to M6-flat .....	94
VIB 3.437 :	Screwed adapter for CLD- /ICP-type accelerometer and VIBROTECTOR, UNF 1/4 to M8-90° .....	94
VIB 3.438 :	Screwed adapter for CLD- /ICP-type accelerometer and VIBROTECTOR, UNF 1/4 to M8-flat .....	94
VIB 3.439 :	Screwed adapter for CLD- /ICP-type accelerometer and VIBROTECTOR, UNF 1/4 to M5-flat .....	94
VIB 3.480 :	M8 thread for CLD- /ICP-type accelerometer and VIBROTECTOR vibration transmitter.....	94
VIB 3.435 :	Screwed adapter for mobile industrial accelerometer, M5-flat to M5-120° .....	95
VIB 3.436 :	Screwed adapter for mobile industrial accelerometer, M5-flat to M6-90° .....	95
VIB 3.440 :	Screwed adapter for mobile industrial accelerometer, M5-flat to M8-90° .....	95
VIB 3.441 :	Screwed adapter for mobile industrial accelerometer, M5-flat to UNC5/16-90° .....	95
VIB 3.474 :	Screwed adapter for industrial accelerometer, M8-90° to M16.....	95
VIB 3.475 :	Screwed adapter for industrial accelerometer, M8-90° to M20.....	95
VIB 8.772 :	Screwed adapter for industrial accelerometer, M8-90° to M10-120° .....	95
VIB 3.418 :	Adhesive adapter for mini accelerometer, UNF 1/4 thread .....	96
VIB 3.430 :	Adhesive adapter for mobile industrial accelerometer, M5-flat .....	96
VIB 3.431 :	Adhesive adapter for industrial accelerometer, M8-90° .....	96
VIB 3.432 :	Adhesive adapter for industrial accelerometer, UNC 5/16-90° .....	96
VIB 3.433 :	Adhesive adapter for CLD-/ICP-type accelerometer and VIBROTECTOR vibration transmitter .....	96
VIB 3.420 :	Magnetic holder for curved surfaces, M5 internal thread .....	97
VIB 3.422 :	Magnetic holder for flat surfaces, M5 internal thread .....	97
VIB 3.423 :	Magnetic holder for flat surfaces, ¼-28 UNF thread.....	97
VIB 8.586 :	Extension post for industrial accelerometer, M8 x 55 mm.....	98
VIB 8.587 :	Extension post for industrial accelerometer, M8 x 95 mm.....	98
VIB 8.588 :	Extension post for industrial accelerometer, M8 x 170 mm.....	98
VIB 8.589 :	Extension post for industrial accelerometer, M8 x 35 mm.....	98

## C

## Contents

1

Order no. Product description Page

VIB 8.590 :	Extension post for industrial accelerometer, UNC 5/16 x 2 1/8" .....	98
VIB 8.591 :	Extension post for industrial accelerometer, UNC 3/8 x 3 3/4" .....	98
VIB 8.592 :	Extension post for industrial accelerometer, UNC 1/2 x 6 5/8" .....	98
VIB 8.679 SET :	VIBCODE measurement stud, M8, high quality stainless steel (VA1.4571), 1 pc.....	99
VIB 8.680 SET :	VIBCODE measurement stud, M8, stainless steel (VA1.4305), 1 pc.....	99
VIB 8.680 A25 :	VIBCODE measurement studs, M8, stainless steel (VA1.4305), 25 pcs.....	99
VIB 8.689 SET :	VIBCODE measurement stud, UNC 5/16, high quality stainless steel (VA1.4571), 1 pc.....	99
VIB 8.689 A25 :	VIBCODE measurement studs, UNC 5/16, high quality stainless steel (VA1.4571), 25 pcs.....	99
VIB 8.690 SET :	VIBCODE measurement stud, UNC 5/16, stainless steel (VA1.4305), 1 pc.....	99
VIB 8.690 A25 :	VIBCODE measurement studs, UNC 5/16, stainless steel (VA1.4305), 25 pcs.....	99
VIB 8.576 :	VIBCODE measurement stud with extension post, M8 x 55 mm.....	100
VIB 8.577 :	VIBCODE measurement stud with extension post, M8 x 95 mm.....	100
VIB 8.578 :	VIBCODE measurement stud with extension post, M8 x 170 mm.....	100
VIB 8.580 :	VIBCODE measurement stud with extension post, UNC 5/16 x 2 1/8" .....	100
VIB 8.581 :	VIBCODE measurement stud with extension post, UNC 3/8 x 3 3/4" .....	100
VIB 8.582 :	VIBCODE measurement stud with extension post, UNC 3/8 x 6 5/8" .....	100
VIB 8.571 :	VIBCODE measurement stud with locking nut, M8 .....	101
VIB 8.572 :	VIBCODE measurement stud with locking nut, M10 .....	101
VIB 8.573 :	VIBCODE measurement stud with locking nut, M12 .....	101
VIB 8.594 :	VIBCODE measurement stud with locking nut, UNC 5/16 .....	101
VIB 8.595 :	VIBCODE measurement stud with locking nut, UNC 3/8 - 16 .....	101
VIB 8.596 :	VIBCODE measurement stud with locking nut, UNC 1/2 -13 .....	101
VIB 8.685 SET :	VIBCODE measurement stud for adhesive mounting, 1 pc.....	102
VIB 8.685 A25 :	VIBCODE measurement stud for adhesive mounting, 25 pcs.....	102
VIB 8.563 A25 :	VIBCODE code ring, 25 pcs.....	103
VIB 8.566 :	Protective cap for VIBCODE stud.....	103
VIB 8.568/B :	Color coding for protective cap, black, 25 pcs.....	103
VIB 8.568/GN :	Color coding for protective cap, green, 25 pcs.....	103
VIB 8.568/GR :	Color coding for protective cap, gray, 25 pcs.....	103
VIB 8.568/W :	Color coding for protective cap, white, 25 pcs.....	103
VIB 8.568/Y :	Color coding for protective cap, yellow, 25 pcs.....	103
VIB 8.692 :	VIBCODE encoding tool.....	103
VIB 6.632 :	Stand for laser trigger / laser RPM sensor .....	104
VIB 3.306 :	Reflective tape .....	104
VIB 32000 :	Measurement stud for accelerometer type VIB 8.666, M8x24, nickel-plated.....	105
VIB 32010 :	Measurement stud for accelerometer type VIB 8.666, M8x24, stainless steel.....	105
VIB 32200 :	Measurement stud for accelerometer type VIB 8.666, M8x113, nickel-plated.....	105
VIB 32210 :	Measurement stud for accelerometer type VIB 8.666, M8x113, stainless steel.....	105
VIB 32310 :	Measurement stud for accelerometer type VIB 8.666, M8x202, stainless steel.....	105
VIB 32410 :	Measurement stud for accelerometer type VIB 8.666, M8x291, stainless steel.....	105
VIB 33000 A25 :	Measurement stud for accelerometer type VIB 8.666, adhesive mount, stainless steel, 25 pcs.....	105
VIB 81025:	Protective cap for measurement stud, black.....	105
VIB 3.450:	Probe tip for mobile industrial accelerometer type VIB 6.14x.....	106
VIB 8.610 :	PRÜFTECHNIK counter sink bit .....	107
VIB 8.693 :	M8 thread tap .....	107
VIB 8.694 :	90° counter sink bit.....	107
VIB 8.696 :	UNC5/16 thread tap .....	107

## Chapter 4

## Cables, interfaces and accessories for permanent installation

VIB 90006 :	Coaxial cable for hazardous areas, PVC cable sheath, blue.....	112
VIB 90007 :	Coaxial cable for high ambient temperatures (< 150°C), oil-resistant .....	112
VIB 90008 :	Coaxial cable for low ambient temperatures (> - 40°C).....	112
VIB 90009 :	Coaxial cable, halogen free and highly flame retardant .....	112
VIB 90093 :	Coaxial cable for high ambient temperatures (< 125°C), oil-resistant .....	112
VIB 90080 :	Standard triaxial cable.....	113
VIB 90180 :	Standard triaxial cable, armored version.....	113
VIB 81026 :	Crimping tool for coaxial cables.....	114
VIB 81052 :	Cutting tool for coaxial cables .....	114
VIB 81053 :	Cable stripper for triaxial cables.....	114
VIB 81054 :	Replacement blade for cable stripper VIB 81053 .....	114

## Contents

Order no.	Product description	Page
VIB 6.730 :	Protective sheath for standard coaxial cables.....	115
VIB 6.725-100 :	Shield connector set for coaxial and twisted-pair cables.....	116
VIB 90061 :	Shielded twisted-pair sensor cable, PUR sheath.....	117
VIB 90065 :	Stranded sensor cable, silicone sheath and cable armor .....	117
VIB 90070 :	Multi-core twisted-pair sensor cable.....	118
VIB 90030 :	Industrial Ethernet cable for WEARSCANNER (CAT5).....	119
VIB 5.740-X :	Pre-assembled sensor cable, silicone sheath and cable armor, straight connector .....	120
VIB 5.741-X :	Pre-assembled sensor cable, silicone sheath and cable armor, angled connector.....	120
VIB 5.745-L :	Pre-assembled sensor cable, PUR sheath, angled connector .....	121
VIB 5.746-L :	Pre-assembled sensor cable, PUR sheath, straight connector (Stainless steel VA 1.4305).....	121
VIB 3.570-L :	Pre-assembled cable for intrinsically safe VIBROTECTOR and ICP-type accelerometers .....	122
VIB 3.575-10 :	Sensor cable for hybrid triaxial accelerometers (VIB 6.215 / VIB 6.216), 10 meters .....	123
VIB 3.575-20 :	Sensor cable for hybrid triaxial accelerometers (VIB 6.215 / VIB 6.216), 20 meters.....	123
VIB 5.771 :	Pre-assembled VIBREX cable .....	124
VIB 309007-6 :	Pre-assembled twisted-pair VIBNODE cable, PUR sheath, 6 meters long .....	125
VIB 309007-10 :	Pre-assembled twisted-pair VIBNODE cable, PUR sheath, 10 meters long .....	125
VIB 309007-15 :	Pre-assembled twisted-pair VIBNODE cable, PUR sheath, 15 meters long .....	125
VIB 309007-20 :	Pre-assembled twisted-pair VIBNODE cable, PUR sheath, 20 meters long .....	125
VIB 7.115-6 :	Pre-assembled coaxial VIBNODE cable, PVC sheath, 6 meters long .....	125
VIB 7.115-12 :	Pre-assembled coaxial VIBNODE cable, PVC sheath, 12 meters long .....	125
VIB 6.420-L :	Pre-assembled WEARSCANNER cable for power supply & data transmission incl. M12 connector VIB 6.421.....	126
VIB 6.426-L :	Pre-assembled WEARSCANNER cable for switching output, incl. M12 connector VIB 6.425 .....	126
VIB 3.550 :	Limiting device for CLD-type accelerometers with intrinsic safety .....	127
0 2088 0009 :	Safety barrier for ICP-type accelerometers with intrinsic safety .....	127
0 2088 0010 :	Transmitter supply unit for VIBROTECTOR EX.....	127
VIB 6.770/9 :	Junction box (aluminium) for the extension of a sensor cable, coaxial - coaxial .....	129
VIB 6.770/13 :	Junction box (aluminium) for the extension of a sensor cable, coaxial - triaxial .....	129
VIB 6.770/9-S :	Junction box (stainless steel) for the extension of a sensor cable, coaxial - coaxial.....	129
VIB 6.770/13-S :	Junction box (stainless steel) for the extension of a sensor cable, coaxial - triaxial.....	129
VIB 6.776 :	Junction box (plastic) for the extension of a sensor cable, twisted-pair / 2-pin .....	129
VIB 6.775/9 :	Junction box for the extension of two sensor cables, coaxial - coaxial .....	131
VIB 6.775/13 :	Junction box for the extension of two sensor cables, coaxial - triaxial .....	131
VIB 8.306 :	Field multiplexer with threaded fitting M12 for VIBRONET Signalmaster.....	132
VIB 8.306 S :	Field multiplexer with threaded fitting M20 for VIBRONET Signalmaster.....	132
VIB 8.306 V :	Field multiplexer with stainless steel housing for VIBRONET Signalmaster .....	132
VIB 8.306 EX :	Field multiplexer for VIBRONET Signalmaster, aluminium housing, intrinsically safe, 224x120 mm .....	133
VIB 8.310 :	Temperature module for VIBRONET field multiplexer .....	134
VIB 8.312 :	Process parameters module (current/ voltage) for VIBRONET field multiplexer.....	134
VIB 8.313 :	RPM module for VIBRONET field multiplexer .....	134
VIB 8.310 EX :	Temperature module for VIBRONET field multiplexer, intrinsically safe .....	134
VIB 8.313 EX :	RPM module for VIBRONET field multiplexer, intrinsically safe .....	134
VIB 8.314 EX :	Vibration module for VIBRONET field multiplexer, intrinsically safe .....	134
VIB 7.560 :	VIBROWEB connection box .....	135
VIB 7.580 :	Open ring spanner, 14x17 .....	136
VIB 7.581 :	Open ring spanner, 19x22 .....	136
VIB 7.582 :	Open ring spanner, 24x27 .....	136
VIB 7.583 :	Open ring spanner, 24x25 .....	136
VIB 7.590 :	Metric cable fitting M 16, 5 pieces.....	137
VIB 7.591 :	Metric cable fitting M 25, 2 pieces .....	137
VIB 7.592 :	Metric cable fitting M 20, 5 pieces .....	137
VIB 7.593 :	Metric cable fitting M 12, 5 pieces .....	137
VIB 7.595 :	Shield clamp SK8, 5 pieces .....	137
VIB 81060 :	Screw driver 2.5 x 35.....	137
VIB 91001 :	TNC plug to threaded fitting, angled, oilproof .....	138
VIB 91002 :	TNC plug to TNC socket, angled .....	138
VIB 91009 :	BNC plug to crimp contact, angled .....	138
VIB 93022 :	TNC plug to crimp contact, straight.....	138
VIB 93031 :	TNC plug to threaded fitting, straight.....	138
VIB 93033 :	TNC socket to TNC socket, straight.....	138
VIB 93047 :	TNC socket to crimp contact, straight.....	138
VIB 93055 :	TNC plug to BNC plug, straight .....	138

## C

## Contents

## 1

Order no.	Product description	Page
-----------	---------------------	------

## 2

VIB 93060 :	BNC plug to crimp contact, straight.....	138
VIB 93062 :	TNC socket to BNC plug, straight.....	138
VIB 93067 :	TNC plug to BNC socket, straight.....	138
VIB 93077 :	TNC plug to crimp contact, angled.....	138
VIB 94010 :	Plug-in connector, 2-pin, straight.....	139
VIB 94011 :	Plug-in connector, 2-pin, angled.....	139
VIB 91000 :	Chassis connector, TNC socket to crimp contact.....	140
VIB 93035 :	Dust cap for TNC socket.....	140
VIB 93036 F :	Bulkhead connector w/ fastening flange, TNC socket to TNC socket.....	140
VIB 93036 S :	Bulkhead connector single hole screw version, TNC socket to TNC socket.....	140
VIB 93056 :	Bulkhead connector w/ fastening flange, BNC socket to TNC socket.....	140
VIB 93061 :	Dust cap for BNC socket.....	140
VIB 93090 :	Chassis connector, BNC socket to crimp contact.....	140
VIB 6.700 :	Dust cap for industrial accelerometer (type VIB 6.1xx), straight, 10 pcs.....	141
VIB 6.701 :	Dust cap for industrial accelerometer (type VIB 6.1xx), straight, oil-resistant, 10 pcs.....	141
VIB 6.710 :	Dust cap for industrial accelerometer (type VIB 6.1xx), angled, 10 pcs.....	141
VIB 6.711 :	Dust cap for industrial accelerometer (type VIB 6.1xx), angled, oil-resistant, 10 pcs.....	141
VIB 6.720 :	Clamp for dust cap, cable end, 10 pcs.....	141
VIB 6.721 :	Clamp for dust cap, sensor end, 10 pcs.....	141
VIB 6.722 :	Dust cap sleeve, 10 pcs.....	141
VIB 8.745 :	Installation checker.....	143
VIB 6.760 :	IP 68 option for industrial accelerometer (type VIB 6.1xx).....	144
VIB 6.761 :	IP 68 option for industrial accelerometer (type VIB 6.1xx), short version.....	144

## 3

## 4

## 5

## 6

## A

**Chapter 5****Sensor cables and connection adapters for mobile data collectors**

VIB 5.436 :	Spiral connection cable for current linedrive accelerometer (VIBSCANNER / VIBXPART).....	147
VIB 5.437-2,9 :	Straight connection cable for current linedrive accelerometer, 2.9 meters (VIBSCANNER / VIBXPART).....	147
VIB 5.437-5 :	Straight connection cable for current linedrive accelerometer, 5 meters (VIBSCANNER / VIBXPART).....	147
VIB 5.444-5 :	Universal cable extension for analog measurement channel, 5 meters.....	148
VIB 5.339:	Cable extension for Current Linedrive accelerometer, 8 meters.....	149
VIB 4.701-2 :	Straight connection cable for CLD-type accelerometer, BNC angled plug, 2 meters (VIBROTIP).....	150
VIB 4.701-5 :	Straight connection cable for CLD-type accelerometer, BNC angled plug, 5 meters (VIBROTIP).....	150
VIB 4.702-2 :	Straight connection cable for CLD-type accelerometer, Microdot angled plug, 2 meters (VIBROTIP).....	150
VIB 4.702-5 :	Straight connection cable for CLD-type accelerometer, Microdot angled plug, 5 meters (VIBROTIP).....	150
VIB 4.704-2 :	Straight connection cable for CLD-type accelerometer, TNC angled plug, 2 meters (VIBROTIP).....	150
VIB 4.704-5 :	Straight connection cable for CLD-type accelerometer, TNC angled plug, 5 meters (VIBROTIP).....	150
VIB 321926-2 :	Spiral connection cable for CLD-type accelerometer, TNC plug, 2 meters (VIBROTIP).....	150
VIB 8.618-1,5 :	TIPTECTOR cable, straight, 1.5 meters (VIBROTIP).....	151
VIB 8.618-5 :	TIPTECTOR cable, straight, 5 meters (VIBROTIP).....	151
VIB 5.438-0.5 :	Straight connection cable for ICP-type accelerometer, 0.5 m, BNC-connector (VIBSCANNER/ VIBXPART).....	152
VIB 5.422 :	Spiral connection cable for ICP-type accelerometer, MIL-connector (VIBSCANNER / VIBXPART).....	152
VIB 5.345-6 :	Cable extension for VIB 5.422, 6 meters, MIL-connector (VIBSCANNER / VIBXPART).....	152
VIB 5.433 :	Cable adapter for the measurement of signal-low voltage with VIBXPART II / VIBSCANNER.....	153
VIB 5.434 :	Cable adapter for the measurement of signal-low current with VIBXPART II / VIBSCANNER.....	153
VIB 5.433 X :	Cable adapter for the measurement of signal-low voltage with VIBXPART EX / VIBSCANNER EX.....	155
VIB 5.432-2,9 :	Connection cable for RPM sensors (VIBSCANNER / VIBXPART).....	157
VIB 4.750-5 :	Cable extension for VIB 5.432-2,9.....	157
VIB 5.443 :	Connection cable for TTL trigger sensors (VIBSCANNER / VIBXPART).....	157
VIB 5.431 :	Cable for analog signal output ( VIBSCANNER / VIBXPART ).....	158
VIB 5.332 :	Keyphasor adapter for machine protection systems (VIBSCANNER / VIBXPART).....	159
VIB 5.332 X :	Keyphasor adapter for machine protection systems (VIBSCANNER EX / VIBXPART EX).....	160
VIB 5.333 :	Cable adapter for TTL / strobe output (VIBXPART).....	161
VIB 5.336 :	Cable adapter for triaxial accelerometer (VIBXPART).....	162
VIB 5.341 :	VST 24V adapter for VIBXPART II.....	163
VIB 5.342 :	Analog cable for VST 24V adapter.....	163



## Contents

Order no.	Product description	Page
VIB 5.343 :	Digital cable for VST 24V adapter .....	163
VIB 5.344 :	VIBROTECTOR cable for VST 24V adapter .....	163
VIB 5.439 :	Connection cable for Pt100 temperature probe (VIBSCANNER) .....	165
VIB 5.445 :	Manual channel switch for 2-plane balancing with VIBSCANNER .....	166
VIB 5.446 :	Automatic channel switch for 2-plane balancing with VIBSCANNER .....	166
VIB 8.749 :	Current Linedrive converter for data collector with voltage input .....	167
VIB 5.449-CLD :	Cable adapter for CLD-type accelerometer VIB 6.195 .....	168
VIB 5.449-ICP :	Cable adapter for ICP-type accelerometer VIB 6.172 .....	168
VIB 4.705 :	BNC to QLA cable adapter .....	169
VIB 8.617 :	QLA angled plug .....	169
VIB 6.780 :	Terminal holder for bulkhead connectors .....	170
VIB 10473 :	Dust cap for TNC connector .....	170
VIB 6.785 :	SwitchBox - Channel switching unit for CLD-/ ICP-type accelerometers, 12 ch. ....	171
VIB 8.746-VD :	SPM cable adapter for VIBROTIP .....	172
VIB 8.746-VS :	SPM cable adapter for VIBSCANNER / VIBXPERT .....	172
VIB 5.346:	Connection cable, VIBXPERT II to VIBRONET field multiplexer .....	173
VIB 5.346-MUX :	BNC connection adapter for cable VIB 5.436 .....	173

## Chapter 6

### Communication cables

VIB 5.330 MUSB :	VIBXPERT II USB cable for peripheral devices (Master) .....	177
VIB 5.330 SUSB :	VIBXPERT II USB cable for communication (Slave) .....	177
VIB 5.330 MEM :	VIBXPERT II adapter for USB pen drive .....	177
VIB 5.330-USB :	VIBXPERT II USB pen drive .....	177
VIB 5.330 UNV :	Universal communication adapter for VIBXPERT EX .....	178
VIB 5.338 :	USB cable for VIBXPERT EX .....	178
VIB 5.331:	VIBXPERT II Ethernet cable .....	180
VIB 5.430-2 :	Serial PC cable (VIBSCANNER / VIBXPERT) .....	181
VIB 5.448 :	Adapter cable, serial to USB (VIBSCANNER / VIBXPERT) .....	181
VIB 8.619 :	Serial PC cable (VIBROTIP) .....	181
VIB 8.619-USB :	Serial to USB cable adapter for VIBROTIP EX .....	182
VIB 5.955-X :	Patch cable (VIBRONET Signalmaster / VIBROWEB) .....	183
VIB 5.957-2 :	Crossover ethernet cable (VIBRONET Signalmaster / VIBROWEB), 2 m .....	183
VIB 5.957-5 :	Crossover ethernet cable (VIBRONET Signalmaster / VIBROWEB), 5 m .....	183
VIB 5.956-X :	System bus cable for VIBRONET Signalmaster with X connectors .....	184

## Appendix

Ordering information for customized sensor cables .....	186
VIB 2.200 : Balancing and Vibration model (Rotor kit) .....	187
Accelerometer performance characteristics (selection) .....	188
Portable instruments connection overview .....	189
Information about installing sensors and cables in hazardous areas .....	192
The patented Tandem-Piezo accelerometer .....	195
Advantages of current linedrive accelerometers .....	196
PRÜFTECHNIK worldwide .....	197
PRÜFTECHNIK Service & Diagnostic Center .....	198
Index by order number .....	199

## C

## Chapter overview

1 For reasons of clarity, the products in this catalog are organized into chapters, which are based on their location and application on-site.

2 Basically this categorization depends on whether the

product can be assigned to the permanently installed on-line systems or to the portable instruments.

The overview below shows the appropriate division of the chapters.

3 Chapter 4  
**Cables, interfaces and accessories for permanent installation**

Chapter 6  
**Communication cables**

4

5

6

A

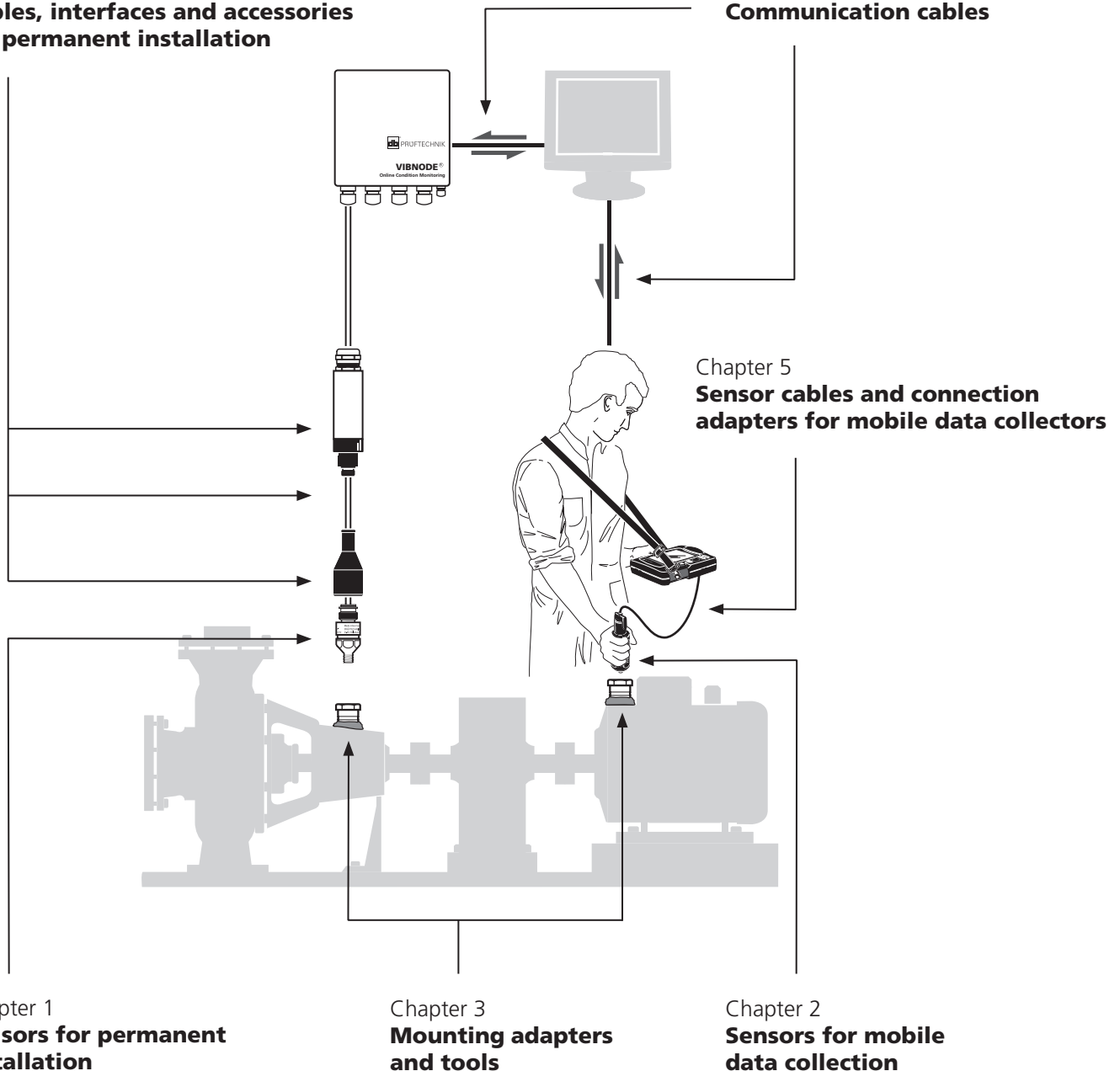

## Chapter contents, organized by location and application

### Chapter 1

#### Sensors for permanent installation

Order no.	Description	Page
VIB 5.991-DIS	Inductive displacement sensor	48
VIB 5.992-NX	Inductive RPM sensor incl. cable	49
VIB 5.992-STD	Default RPM sensor for Online CMS	50
VIB 5.993-MIC	Microphone	56
VIB 5.731 VIB 5.736	VIBROTECTOR vibration transmitter, 10 mm/s or 20 mm/s	32
VIB 5.731 EX VIB 5.736 EX	VIBROTECTOR vibration transmitter, 10 mm/s or 20 mm/s, intrinsically safe	44
VIB 6.102 R	Industrial accelerometer for standard machinery, adhesive mount	20
VIB 6.102 DEX	-, intrinsically safe	36
VIB 6.107	Industrial accelerometer for low-speed machinery, adhesive mount	22
VIB 6.107 DEX	-, intrinsically safe	40
VIB 6.122 R	Industrial accelerometer for standard machinery, M8 thread mount	20
VIB 6.122 DEX	-, intrinsically safe	36
VIB 6.125 R	-, high-temperature version	20
VIB 6.125 RIP VIB 6.125 IDEX	-, suitable for IP 68 option --, intrinsically safe	24
VIB 6.127	Industrial accelerometer for low-speed machinery, M8 thread mount	22
VIB 6.127 DEX	-, intrinsically safe	40
VIB 6.129 IP VIB 6.129 IDEX	-, suitable for IP 68 option --, intrinsically safe	24
VIB 6.132 R	Industrial accelerometer for standard machinery, UNC 5/16 thread mount	20
VIB 6.132 DEX	-, intrinsically safe	36
VIB 6.135 R	-, high-temperature version	20
VIB 6.137	Industrial accelerometer for low-speed machinery, UNC 5/16 thread mount	22
VIB 6.137 DEX	-, intrinsically safe	40
VIB 6.152 DEX	Industrial accelerometer, low sensitivity, intrinsically safe	38
VIB 6.172	ICP-type accelerometer for very low- speed machinery 0.1 Hz - 10 kHz	34
VIB 6.172 XICP	-, intrinsically safe	46
VIB 6.195	CLD-type accelerometer for very low- speed machinery 0.1 Hz - 10 kHz	34
VIB 6.202-3 /-6 VIB 6.203-3 /-6	Mini accelerometer, RG 174 or Spec 44, 3 m / 6 m	26
VIB 6.202...XD VIB 6.203...XD	-, intrinsically safe	42
VIB 6.215 VIB 6.216	Triaxial accelerometers for VIBGUARD 1 Hz ... 10 kHz 0.1 Hz ... 10 kHz	30

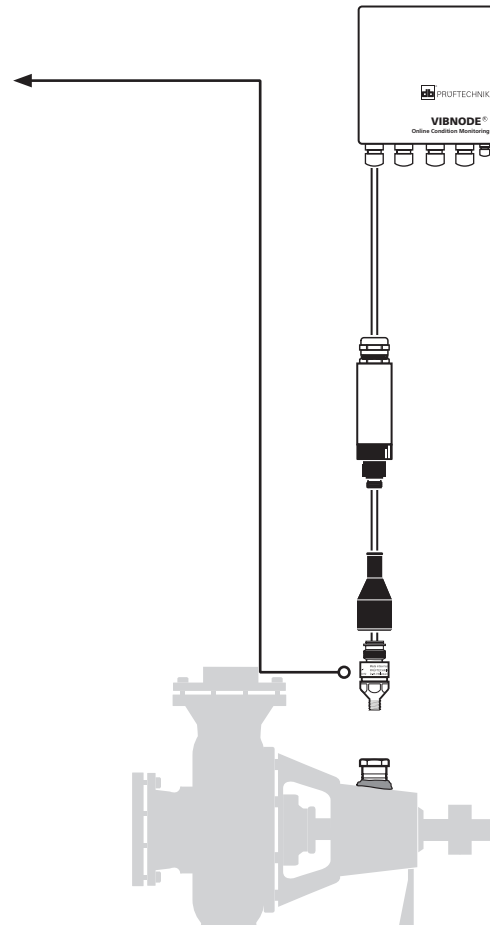

Order no.	Description	Page
VIB 6.411 SET	WEARSCANNER particle counter	58
VIB 6.610	Temperature probe PT100	51
VIB 6.620 SET VIB 6.621	Inductive RPM sensor for VIBRONET Sig- nalmaster incl. connector (f< 300 Hz) Connector for sensor VIB 6.620	52
VIB 6.622 SET VIB 6.621	Inductive RPM sensor for VIBRONET Sig- nalmaster incl. connector (f<1500 Hz) Connector for sensor VIB 6.622	53
VIB 6.641	Proximity sensor for Online CMS incl. cable (3-15 mm)	54
VIB 6.645 SET VIB 6.646	Displacement sensor for Online CMS incl. cable (2-10 mm) Connection cable for sensor VIB 6.645	55
VIB 7.205-2,9	VIBCONNECT RF sensor	28

## C

## Chapter contents, organized by location and application

1

2

3

4

5

6

A

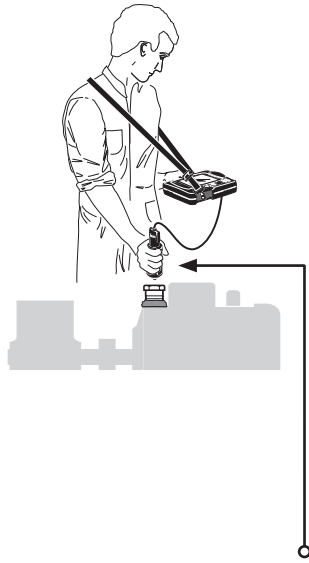

## Chapter 2

## Sensors for mobile data collection

Order no.	Description	Page
VIB 6.142 R	Mobile industrial accelerometer for standard machinery	68
VIB 6.142 DEX	Mobile industrial accelerometer for standard machinery, intrinsically safe	70
VIB 6.147	Mobile industrial accelerometer for low-speed machinery	69
VIB 6.147 DEX	Mobile industrial accelerometer for low-speed machinery, intrinsically safe	72
VIB 6.162 VD VIB 6.162 VT	Dual sensor for vibration and temperature measurement with VIBSCANNER/ VIBXPART (VD) VIBTOOL (VT)	74
VIB 6.631	Laser trigger / Laser RPM sensor	84
VIB 6.631 EX	Laser trigger / Laser RPM sensor, intrinsically safe	86
VIB 6.640	Inductive proximity sensor for VIBXPART / VIBSCANNER	88
VIB 6.655	Triaxial accelerometer for VIBXPART	81
VIB 6.672	LED stroboscope	89
VIB 6.673	Current clamp	90

Order no.	Description	Page
VIB 8.605	Built-in temperature probe for VIBROTIP / VIBSCANNER (spare part)	82
VIB 8.606 VD VIB 8.606 VS	TIPTECTOR handheld probe, -, set for VIBROTIP -, set for VIBSCANNER / VIBXPART	76
VIB 8.606 XVD VIB 8.606 XVS	TIPTECTOR handheld probe, intr. safe -, set for VIBROTIP EX -, set for VIBSCANNER EX	78
VIB 8.607-1,5 VIB 8.608	Temp. probe with magnetic holder Hand-held temperature probe	82
VIB 8.609 VIB 8.633	TIPTECTOR grip extension, 100 mm TIPTECTOR grip	76
VIB 8.660 VS VIB 8.660 VD VIB 8.660 VIB 8.691	VIBCODE transducer incl. cable -, for VIBSCANNER and VIBXPART -, for VIBROTIP -, as replacement part w/o cable Dust cap for VIBCODE transducer	64
VIB 8.660 XVS VIB 8.660 XVD VIB 8.660 HEX	VIBCODE transducer incl. cable, int. safe -, for VIBSCANNER EX and VIBXPART EX -, for VIBROTIP EX and VIBTOOL -, as replacement part w/o cable	66
VIB 8.666 VD VIB 8.666 VS VIB 8.666 R	Mobile accelerometer with quick fitting coupling incl. cable -, for VIBROTIP -, for VIBSCANNER / VIBXPART -, as replacement part w/o cable	80

## Chapter contents, organized by location and application

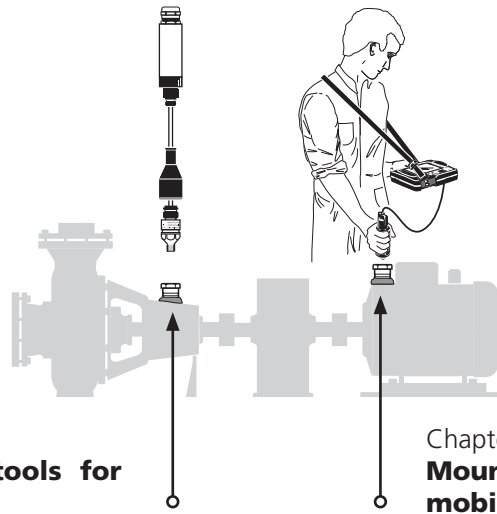

### Chapter 3

#### Mounting adapters and tools for permanent installation

Order no.	Description	Page
VIB 3.411 VIB 3.412 VIB 3.413 VIB 3.414 VIB 3.415 VIB 3.416	Screwed adapter with locking nut for industrial accelerometers -, M8 to M8 -, M8 to M10 -, M8 to M12 -, UNC 5/16 to UNC 5/16 -, UNC 5/16 to UNC 3/8 - 16 -, UNC 5/16 to UNC 1/2 - 13	93
VIB 3.417-M5 VIB 3.417-M6	Screwed adapter for mini accelerometer, -, UNF1/4 to M5 -, UNF1/4 to M6	94
VIB 3.418 VIB 3.431 VIB 3.432 VIB 3.433	Adhesive adapter for -, mini accelerometer -, industrial accelerometer, M8-90° -, industrial accelerometer, UNC 5/16 -, CLD-/ICP-type accelerometer and VIBROTECTOR vibration transmitter	96
VIB 3.437 VIB 3.438 VIB 3.439	Screwed adapter for CLD-/ICP-type accelerometer and VIBROTECTOR -, UNF 1/4 to M8/90° -, UNF 1/4 to M8 -, UNF 1/4 to M5	94
VIB 3.474 VIB 3.475 VIB 8.772	Screwed adapter for industrial accelerometers, -, M8-90° to M16 -, M8-90° to M20 -, M8-90° to M10-120°	95
VIB 3.480	M8 thread for CLD-/ICP-type accelerometer and VIBROTECTOR vibration transmitter	94
VIB 8.586 VIB 8.587 VIB 8.588 VIB 8.589 VIB 8.590 VIB 8.591 VIB 8.592	Extension post for industrial accelerometer -, M8 x 55 mm -, M8 x 95 mm -, M8 x 170 mm -, M8 x 35 mm -, UNC 5/16 x 2 1/8" -, UNC 5/16 x 3 3/4" -, UNC 5/16 x 6 5/8"	98
VIB 8.693 VIB 8.694 VIB 8.696	M8 thread tap 90° counter sink bit UNC5/16 thread tap	107

### Chapter 3

#### Mounting adapters and tools for mobile data collection

Order no.	Description	Page
VIB 3.306	Reflective tape for laser trigger	104
VIB 3.420 VIB 3.422 VIB 3.423	Magnetic holder for -, curved surfaces, M5 -, flat surfaces, M5 -, flat surfaces, ¼-28 UNF	97
VIB 3.430	Adhesive adapter, M5	96
VIB 3.435 VIB 3.436 VIB 3.440 VIB 3.441	Screwed adapter -, M5-flat to M5-120° -, M5 to M6 -, M5 to M8 -, M5 to UNC 5/16	95
VIB 3.450	Probe tip, M5	106
VIB 6.632	Stand for laser trigger / laser RPM sensor	104
VIB 8.563 A25 VIB 8.566 VIB 8.568	VIBCODE code ring, 25 pcs. Protective cap for VIBCODE stud Color coding for protective cap	103
VIB 8.571 VIB 8.572 VIB 8.573 VIB 8.594 VIB 8.595 VIB 8.596	VIBCODE meas. stud w/ locking nut -, M8 -, M10 -, M12 -, UNC 5/16-18 -, UNC 3/8-16 -, UNC 1/2-13	101
VIB 8.576 VIB 8.577 VIB 8.578 VIB 8.580 VIB 8.581 VIB 8.582	VIBCODE meas. stud w/ extension post -, M8 x 55 -, M8 x 95 -, M8 x 170 -, UNC 5/16 x 2 1/8" -, UNC 5/16 x 3 3/4" -, UNC 5/16 x 6 5/8"	100
VIB 8.610	PRÜFTECHNIK counter sink bit	107
VIB 8.679 SET VIB 8.680 SET	VIBCODE meas. stud -, M8, VA 1.4571 -, M8, VA 1.4305	99
VIB 8.685 SET	VIBCODE measurement stud for adhesive mounting	102
VIB 8.689 SET VIB 8.690 SET	VIBCODE meas. stud -, UNC 5/16, VA 1.4571 -, UNC 5/16, VA 1.4305	99
VIB 8.692	VIBCODE encoding tool	103
VIB 32000 VIB 32010 VIB 32200 VIB 32210 VIB 32310 VIB 32410 VIB 33000A25	Meas. stud for accelerometer VIB 8.666 -, M8x24, nickel-plated -, M8x24, stainless steel -, M8x113, nickel-plated -, M8x113, stainless steel -, M8x202, stainless steel -, M8x291, stainless steel -, adhesive mount	105
VIB 81025	Protective cap for measurement stud	105

## C

## Chapter contents, organized by location and application

## Chapter 4

## Cabel interfaces

Order no.	Description	Page
0 2088 0009 0 2088 0010 VIB 3.550	Safety barrier for ICP-type accelerometers Transmitter supply unit VIBROTECTOR EX Limiting device, CLD-type accelerometers	127
VIB 7.560	VIBROWEB connection box	135
VIB 6.770/9 VIB 6.770/13 VIB 6.776	Junction box (extension of a sensor cable) -, coaxial - coaxial -, coaxial - triaxial -, twisted-pair/ 2-pin	129
VIB 6.775/9 VIB 6.775/13	Junction box (extension of 2 sensor cables) -, coaxial - coaxial -, coaxial - triaxial	131
VIB 8.306 VIB 8.306 S VIB 8.306 V	VIBRONET field multiplexer, 9-channel, -, w/ threaded fitting M12 -, w/ threaded fitting M20 -, stainless steel housing, M20	132
VIB 8.306 EX	VIBRONET field multiplexer, 9-channel, -, intrinsically safe, aluminium housing	133
VIB 8.310 VIB 8.310 EX VIB 8.312 VIB 8.313 VIB 8.313 EX VIB 8.314 EX	Connection modules for VIBRONET MUX Temperature module -, intrinsically safe Process parameters module (U / I) RPM module -, intrinsically safe Vibration module, intrinsically safe	134

## Chapter 4

## Cables for permanent installation

Order no.	Description	Page
VIB 3.570-L	Pre-assembled cable for intrins. safe VIBROTECTOR and ICP-type accelerometers	122
VIB 3.575-10 VIB 3.575-20	Sensor cable for triaxial accelerometers (VIB 6.215 / VIB 6.216), 10 / 20 meters	123
VIB 5.740-X VIB 5.741-X	Sensor cable for VIBROTECTOR & CLD-/ICP-type accelerometers -, silicone sheath, straight connector -, silicone sheath, angled connector	120
VIB 5.745-L VIB 5.746-L	Sensor cable for VIBROTECTOR & CLD-/ICP-type accelerometers -, PUR sheath, angled connector -, PUR sheath, straight connector	119
VIB 5.771	Pre-assembled VIBREX cable	124
VIB 6.420-L VIB 6.426-L	Pre-assembled WEARSCANNER cables... for power supply & data transmission for switching output	126
VIB 7.115-6 VIB 7.115-12	Pre-assembled VIBNODE cables -, Twisted-pair (TP), 6 m -, Twisted-pair (TP), 12 m	125
VIB 90006 VIB 90007 VIB 90008 VIB 90009 VIB 90093	Coaxial cable RG58 -, for hazardous areas (blue) -, oil-resistant, max. 150°C -, for low ambient temperatures > - 40°C -, halogen free & highly flame retardant -, oil-resistant, max. 125°C	112
VIB 90030	Industrial Ethernet cable, CAT5	119
VIB 90061 VIB 90065	Twisted-pair sensor cable, PUR sheath Sensor cable, silicone and cable armor	117
VIB 90070	Multi-core twisted-pair sensor cable	118
VIB 90080 VIB 90180	Standard triaxial cable Standard triaxial cable, armored version	113
VIB 309007- 6 VIB 309007-10 VIB 309007-15 VIB 309007-20	Pre-assembled VIBNODE cables -, coaxial, 6 m -, coaxial, 10 m -, coaxial, 15 m -, coaxial, 20 m	125

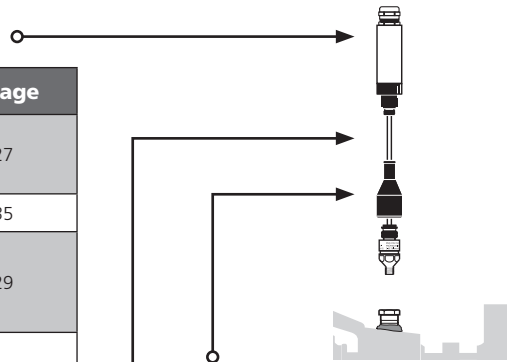

## Chapter 4

## Accessories for cable connection

Order no.	Description	Page
VIB 6.700 VIB 6.701 VIB 6.710 VIB 6.711 VIB 6.720 VIB 6.721 VIB 6.722	Dust caps for accelerometers VIB 6.1xx -, straight -, straight and oil-resistant -, angled -, angled and oil-resistant Clamp for dust cap, cable end -, sensor end Dust cap sleeve	141
VIB 6.725-100	Shield connector set for coaxial and twisted-pair cables	116
VIB 6.730	Protective sheath for coaxial cables	115
VIB 6.760 VIB 6.761	IP 68 option for accelerometer VIB 6.1xx -, short version	144
VIB 7.580..3	Open ring spanners size 14x17 / 19x22 / 24x27 / 24x25	136
VIB 7.590..3 VIB 7.595	Metric cable fittings M16 / M20 / M25 / M12 Shield clamp SK8	137
VIB 8.718	Cable clamp for prot. sheath VIB 6.730	115
VIB 8.745	Installation checker	143
VIB 81015	Protective sleeve for cable type RG 174	26
VIB 81026 VIB 81052 VIB 81053 VIB 81054	Crimping tool for coaxial cables Cutting tool for coaxial cables Cable stripper for triaxial cables Placement blade for cable stripper	114
VIB 81060	Screw driver 2.5 x 35	137
VIB 91000	Chassis connector, TNC socket to crimp	140
VIB 91001 VIB 91002 VIB 91009 VIB 93022	TNC plug to threaded fitting, angled TNC plug to TNC socket, angled BNC plug to crimp contact, angled TNC plug to crimp contact, straight	138
VIB 93025	TNC plug to crimp contact, RG174 cable	26
VIB 93031 VIB 93033	TNC plug to threaded fitting, straight TNC socket to TNC socket, straight	138
VIB 93035 VIB 93036 F VIB 93036 S	Dust cap for TNC socket Bulkhead connector w/ fastening flange -, single hole screw version	140
VIB 93047 VIB 93055	TNC socket to crimp contact, straight TNC plug to BNC plug, straight	138
VIB 93056	Bulkhead connector, flange, BNC- TNC	140
VIB 93060	BNC plug to crimp contact, straight	138
VIB 93061	Dust cap for BNC socket	140
VIB 93062 VIB 93067 VIB 93077	TNC socket to BNC plug, straight TNC plug to BNC socket, straight TNC plug to crimp contact, angled	138
VIB 93090	Chassis connector, BNC socket to crimp	140
VIB 94010 VIB 94011	Plug-in connector, 2-pin, straight Plug-in connector, 2-pin, angled	139

## Chapter contents, organized by location and application

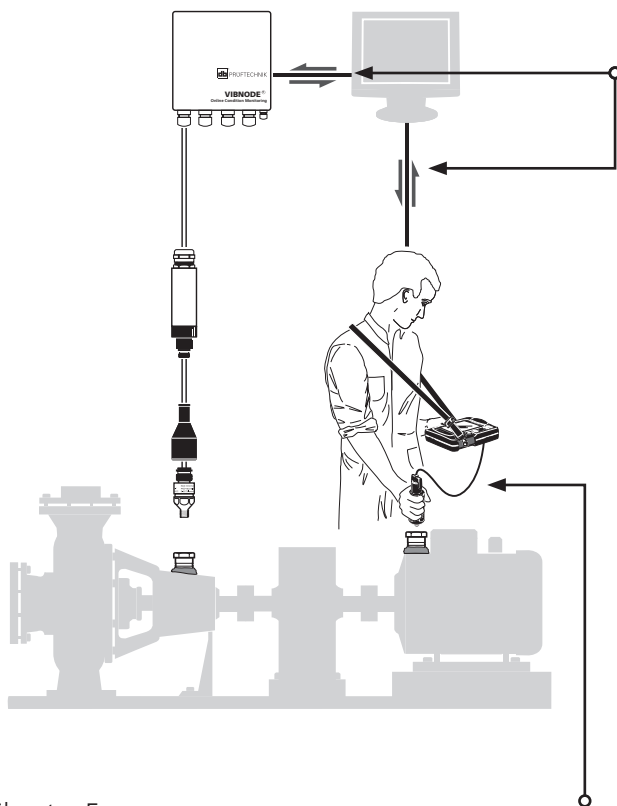

### Chapter 5

#### Sensor cables and connection adapters for data collectors

Order no.	Description	Page
VIB 321926-2	Spiral cable, TNC-QLA	150
VIB 4.701-2 VIB 4.701-5 VIB 4.702-2 VIB 4.702-5 VIB 4.704-2 VIB 4.704-5	Straight cable, BNC - QLA, 2 m -, BNC - QLA, 5 m -, Microdot - QLA, 2 m -, Microdot-QLA, 5 m -, TNC - QLA, 2 m -, TNC - QLA, 5 m	150
VIB 4.750-5	Cable extension for RPM sensor, 5m	157
VIB 5.332	Keyphasor adapter for machine protection systems, VIBSCANNER / VIBXPERT	159
VIB 5.332 X	Keyphasor adapter for machine protection systems, VIBSCANNER EX / VIBXPERT EX	160
VIB 5.333	Cable adapter for TTL / strobe output, VIBXPERT	161
VIB 5.336	Cable adapter for triaxial accelerometer VIB 6.655, VIBXPERT	162
VIB 5.339	Cable extension for Current Linedrive accelerometer, 8 meters	149
VIB 5.341 VIB 5.342 VIB 5.343 VIB 5.344	VST 24V adapter for VIBXPERT Analog cable for VST 24V adapter Digital cable for VST 24V adapter VIBROTECTOR cable for VST 24V	163
VIB 5.345-6 VIB 5.422	Cable extension for VIB 5.422 Spiral connection cable for ICP-type accelerometer, MIL-connector	152
VIB 5.346 VIB 5.346-MUX	VIBXPERT II connection cable for VIBRONET field multiplexer VIB 8.306 BNC adapter for cable VIB 5.346	173
VIB 5.431	Cable for analog signal output	158
VIB 5.432-2,9	Connection cable for RPM sensors	157

### Chapter 6

#### Communication cables

Order no.	Description	Page
VIB 5.330 MUSB VIB 5.330 SUSB VIB 5.330 MEM VIB 5.330-USB	VIBXPERT USB cable for periph. devices VIBXPERT USB cable for PC VIBXPERT II adapter for USB pen drive VIBXPERT II USB pen drive	177
VIB 5.330-UNV	Universal communication adapter for VIBXPERT EX	178
VIB 5.331	Ethernet cable, VIBXPERT	180
VIB 5.338	USB cable, VIBXPERT EX	178
VIB 5.430-2 VIB 5.448	Serial PC cable, VIBSCANNER / VIBXPERT Adapter cable, serial to USB, VIBSCANNER / VIBXPERT	181
VIB 5.955-X VIB 5.957-2 /-5	Patch cable, VIBRONET / VIBROWEB Crossover ethernet cable, VIBRONET / VIBROWEB	183
VIB 5.956-X	System bus cable, VIBRONET	184
VIB 8.619	Serial PC cable, VIBROTIP	181
VIB 8.619-USB	Serial to USB cable adapter, VIBROTIP EX	182

**C**

1

2

3

4

5

6

A



# Chapter 1

## Sensors for permanent installation



C

**1**

2

3

4

5

6

A

## Contents : Sensors for permanent installation

Order no.	Description	Page
VIB 5.991-DIS	Inductive displacement sensor	48
VIB 5.992-NX	Inductive RPM sensor incl. cable	49
VIB 5.992-STD	Default RPM sensor for Online CMS	50
VIB 5.993-MIC	Microphone	56
VIB 5.731 VIB 5.736	VIBROTECTOR vibration transmitter, 10 mm/s or 20 mm/s	32
VIB 5.731 EX VIB 5.736 EX	VIBROTECTOR vibration transmitter, 10 mm/s or 20 mm/s, intrinsically safe	44
VIB 6.102 R	Industrial accelerometer for standard machinery, adhesive mount	20
VIB 6.102 DEX	-, intrinsically safe	36
VIB 6.107	Industrial accelerometer for low-speed machinery, adhesive mount	22
VIB 6.107 DEX	-, intrinsically safe	40
VIB 6.122 R	Industrial accelerometer for standard machinery, M8 thread mount	20
VIB 6.122 DEX	-, intrinsically safe	36
VIB 6.125 R	-, high-temperature version	20
VIB 6.125 RIP VIB 6.125 IDEX	-, suitable for IP 68 option --, intrinsically safe	24
VIB 6.127	Industrial accelerometer for low-speed machinery, M8 thread mount	22
VIB 6.127 DEX	-, intrinsically safe	40
VIB 6.129 IP VIB 6.129 IDEX	-, suitable for IP 68 option --, intrinsically safe	24
VIB 6.132 R	Industrial accelerometer for standard machinery, UNC 5/16 thread mount	20
VIB 6.132 DEX	-, intrinsically safe	36
VIB 6.135 R	-, high-temperature version	20
VIB 6.137	Industrial accelerometer for low-speed machinery, UNC 5/16 thread mount	22
VIB 6.137 DEX	-, intrinsically safe	40
VIB 6.152 DEX	Industrial accelerometer, low sensitivity, intrinsically safe	38
VIB 6.172	ICP-type accelerometer for very low- speed machinery 0.1 Hz - 10 kHz	34
VIB 6.172 XICP	-, intrinsically safe	46
VIB 6.195	CLD-type accelerometer for very low- speed machinery 0.1 Hz - 10 kHz	34
VIB 6.202-3 /-6 VIB 6.203-3 /-6	Mini accelerometer, RG 174 or Spec 44, 3 m / 6 m	26
VIB 6.202...XD VIB 6.203...XD	-, intrinsically safe	42

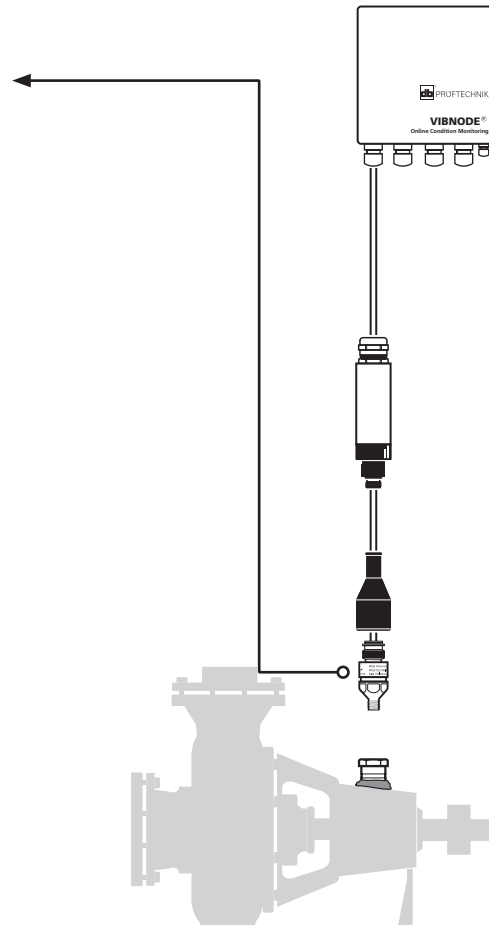

Order no.	Description	Page
VIB 6.215 VIB 6.216	Triaxial accelerometers for VIBGUARD 1 Hz ... 10 kHz 0.1 Hz ... 10 kHz	30
VIB 6.411 SET	WEARSCANNER particle counter	58
VIB 6.610	Temperature probe PT100	51
VIB 6.620 SET VIB 6.621	Inductive RPM sensor for VIBRONET Sig- nalmaster incl. connector (f< 300 Hz) Connector for sensor VIB 6.620	52
VIB 6.622 SET VIB 6.621	Inductive RPM sensor for VIBRONET Sig- nalmaster incl. connector (f<1500 Hz) Connector for sensor VIB 6.622	53
VIB 6.641	Proximity sensor for Online CMS incl. cable (3-15 mm)	54
VIB 6.645 SET VIB 6.646	Displacement sensor for Online CMS incl. cable (2-10 mm) Connection cable for sensor VIB 6.645	55
VIB 7.205-2,9	VIBCONNECT RF sensor	28

C

## Industrial accelerometers for standard machinery ( $n > 60 \text{ min}^{-1}$ )

1

VIB 6.102 R : Industrial accelerometer for standard machinery, adhesive mount

VIB 6.122 R : Industrial accelerometer for standard machinery, M8 thread mount

VIB 6.132 R : Industrial accelerometer for standard machinery, UNC 5/16 thread mount

2

VIB 6.125 R : Industrial accelerometer for standard machinery, M8 thread mount, high-temperature version

VIB 6.135 R : Industrial accelerometer for standard machinery, UNC 5/16 thread mount, high-temperature version

3

4

5

6

A



Adhesive mount



Thread mount



Vibration acceleration



Bearing condition



Pump cavitation

### Application

These accelerometers are suitable for vibration measurements up to 20 kHz on machinery with rotational speeds above  $60 \text{ min}^{-1}$ , for shock pulse measurements on roller bearings and for cavitation measurements in pumps.

The accelerometers are mainly used for continuous machine condition monitoring in an industrial environment. The signal acquisition and processing is carried out with a condition monitoring system from PRÜFTECHNIK (e.g. VIBNODE, VIBROWEB,...).

### Installation accessories

Mounting tools for screw threads:

VIB 8.693 M8 screw tap  
 VIB 8.696 UNC 5/16 screw tap  
 VIB 8.694 90° countersink bit

Mounting adapters for M8 screw threads:

VIB 3.474 Screwed adapter to M16  
 VIB 3.475 Screwed adapter to M20  
 VIB 8.772 Screwed adapter to M10  
 VIB 3.411 -, w/ locking nut to M8  
 VIB 3.412 -, w/ locking nut to M10  
 VIB 3.413 -, w/ locking nut to M12  
 VIB 3.431 -, w/ adhesive mount

Mounting adapters for UNC 5/16 screw threads:

VIB 3.414 Screwed ad. w/ locking nut to UNC 5/16  
 VIB 3.415 -, w/ locking nut to UNC 3/8 - 16  
 VIB 3.416 -, w/ locking nut to UNC 1/2 - 13  
 VIB 3.432 -, w/ adhesive mount

Extension post for M8 screw threads:

VIB 8.586 length: 55 mm  
 VIB 8.587 length: 95 mm  
 VIB 8.588\* length: 170 mm  
 VIB 8.589 length: 35 mm

Extension post for UNC 5/16 screw threads:

VIB 8.590 length: 2 1/8"  
 VIB 8.591 length: 3 3/4"  
 VIB 8.592\* length: 6 5/8"

\* only for shock pulse measurements!

Installation material for adhesive mount:  
 2-component adhesive (e.g. WEICON HB 300).

## Technical data

PARAMETER		VIB 6.102 R	VIB 6.122 R	VIB 6.132 R	VIB 6.125 R	VIB 6.135 R
Measurement	Signaling system	Current LineDrive, 3.5 mA closed current with superposed AC signal				
	Transmission factor ± 3%	1.0 $\mu\text{A}/\text{ms}^{-2}$ (Reference: 159 Hz; 25 °C)				
	Frequency range ± 5%	2 Hz ... 8 kHz				
	± 10%	1 Hz ... 12 kHz				
	± 3dB	1 Hz ... 20 kHz				
	Resonance frequency	36 kHz				
	Linearity range ± 10%	± 961 $\text{ms}^{-2}$				
	Temperature range, w/ Rayolin cable	-30 °C ... +80 °C	-30 °C ... +100 °C		-30 °C ... +125 °C	
w/ Teflon cable	not available			-30 °C ... +135 °C (short-term up to +150 °C)		
Electrical	Power requirement	> 10 mA / 7-18 VDC				
	Transverse sensitivity	< 5% at 10 kHz				
	Temperature sensitivity	< 0.05 $\text{ms}^{-2}/\text{K}$				
	Magnetic sensitivity	< 5 $\text{ms}^{-2}/\text{T}$ (at 50 Hz)				
	Base strain sensitivity	< 0.1 $\text{ms}^{-2}/\mu\text{m}/\text{m}$				
	Electrical noise, rms	< 0.01 $\text{ms}^{-2}$ from 2 Hz				
	Output impedance	> 1 MOhm				
	Insulation	> 10 <sup>9</sup> MOhm				
Mechanical	Case material	Stainless steel VA 1.4305				
	Environmental protection	IP 65 (w/ cable)				
	Cable connection	TNC socket				
	Shock limit	< 250 $\text{kms}^{-2}$				
	Weight	40 g				
	Installation height A (see below)					
	w/ coaxial cable & straight TNC plug	> 119 mm	> 115 mm			
	... and angled TNC plug	59 mm	55 mm			
	Mounting	Adhesive	M8 thread	UNC 5/16 thread	M8 thread	UNC 5/16 thread

### Dimensions

in mm

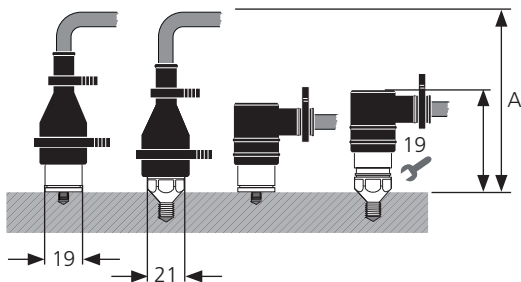

### Frequency response

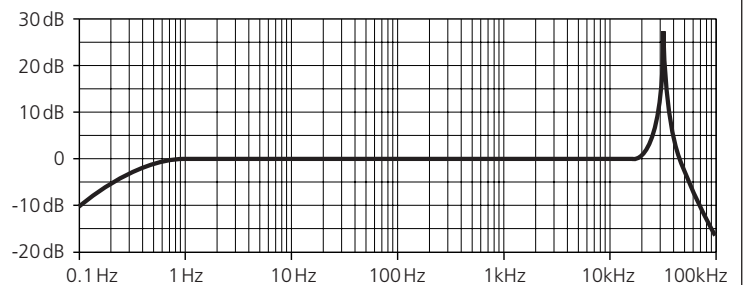

C

## Industrial accelerometers for low-speed machinery ( $n > 20 \text{ min}^{-1}$ )

1

VIB 6.107 : Industrial accelerometer for low-speed machinery, adhesive mount

VIB 6.127 : Industrial accelerometer for low-speed machinery, M8 thread mount

VIB 6.137 : Industrial accelerometer for low-speed machinery, UNC 5/16 thread mount

2

3

4

5



Adhesive mount



Thread mount



Vibration acceleration

6

### Application

These accelerometers are suitable for vibration measurements up to 10 kHz on low-speed machinery with rotational speeds above  $20 \text{ min}^{-1}$ . High frequency shock pulse measurements for bearing condition evaluation and pump cavitation are not possible with this series.

The accelerometers are mainly used for continuous machine condition monitoring in an industrial environment. The signal acquisition and processing is carried out with a condition monitoring system from PRÜFTECHNIK (e.g. VIBNODE, VIBROWEB,...).

A

### Installation accessories

Mounting tools for screw threads:

VIB 8.693 M8 screw tap  
 VIB 8.696 UNC 5/16 screw tap  
 VIB 8.694 90° countersink bit

Mounting adapters for M8 screw threads:

VIB 3.474 Screwed adapter to M16  
 VIB 3.475 Screwed adapter to M20  
 VIB 8.772 Screwed adapter to M10  
 VIB 3.411 -, w/ locking nut to M8  
 VIB 3.412 -, w/ locking nut to M10  
 VIB 3.413 -, w/ locking nut to M12  
 VIB 3.431 -, w/ adhesive mount

Mounting adapters for UNC 5/16 screw threads:

VIB 3.414 Screwed ad. w/ locking nut to UNC 5/16  
 VIB 3.415 -, w/ locking nut to UNC 3/8 - 16  
 VIB 3.416 -, w/ locking nut to UNC 1/2 - 13  
 VIB 3.432 -, w/ adhesive mount

Extension post for M8 screw threads:

VIB 8.586 length: 55 mm  
 VIB 8.587 length: 95 mm  
 VIB 8.588\* length: 170 mm  
 VIB 8.589 length: 35 mm

Extension post for UNC 5/16 screw threads:

VIB 8.590 length: 2 1/8"  
 VIB 8.591 length: 3 3/4"  
 VIB 8.592\* length: 6 5/8"  
 \* only for shock pulse measurements!

Installation material for adhesive mount:  
 2-component adhesive (e.g. WEICON HB 300).

## Technical data

PARAMETER		VIB 6.107	VIB 6.127	VIB 6.137
Measurement	Signaling system	Current LineDrive, 3.5 mA closed current with superposed AC signal		
	Transmission factor $\pm 4\%$	5.35 $\mu\text{A}/\text{ms}^{-2}$ (Reference: 159 Hz; 25 °C)		
	Frequency range $\pm 5\%$	2 Hz ... 4 kHz		
	$\pm 10\%$	1 Hz ... 6 kHz		
	$\pm 3\text{dB}$	0.3 Hz ... 10 kHz		
	Resonance frequency	17 kHz; > 20 dB damped		
	Linearity range $\pm 10\%$	$\pm 450 \text{ ms}^{-2}$		
Electrical	Temperature range, w/ Rayolin cable	-30 °C ... +80 °C	-30 °C ... +100 °C	
	Power requirement	> 10 mA / 7-18 VDC		
	Transverse sensitivity	< 5% at 10 kHz		
	Temperature sensitivity	< 0.01 $\text{ms}^{-2}/\text{K}$		
	Magnetic sensitivity	< 1 $\text{ms}^{-2}/\text{T}$ (at 50 Hz)		
	Base strain sensitivity	< 0.1 $\text{ms}^{-2}/\mu\text{m}/\text{m}$		
	Electrical noise, rms	< 0.002 $\text{ms}^{-2}$ from 2 Hz		
	Output impedance	> 300 kOhm		
	Insulation	> 10 <sup>9</sup> MOhm		
	Mechanical	Case material	Stainless steel VA 1.4305	
Environmental protection		IP 65 (w/ cable)		
Cable connection		TNC socket		
Shock limit		< 50 $\text{kms}^{-2}$		
Weight		41 g	43 g	
Installation height A (see below)				
w/ coaxial cable & straight TNC plug		> 124 mm	> 120 mm	
... and angled TNC plug		64 mm	60 mm	
Mounting		Adhesive	M8 thread	UNC 5/16 thread

### Dimensions

in mm

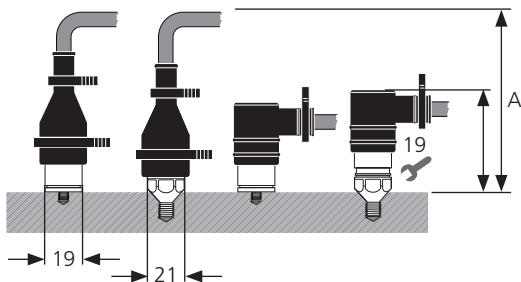

### Frequency response

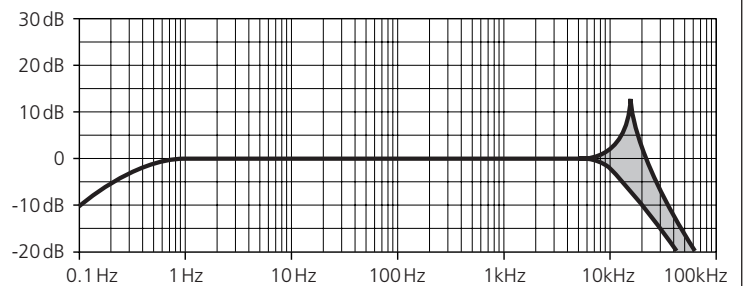

C

## Industrial accelerometers for use in liquid media (IP 68)

1

VIB 6.125 RIP : Industrial accelerometer for standard machinery ( $n > 60 \text{ min}^{-1}$ )

VIB 6.125 IDEX : Industrial accelerometer for standard machinery ( $n > 60 \text{ min}^{-1}$ ), intrinsically safe

VIB 6.129 IP : Industrial accelerometer for low-speed machinery ( $n > 20 \text{ min}^{-1}$ )

VIB 6.129 IDEX : Industrial accelerometer for low-speed machinery ( $n > 20 \text{ min}^{-1}$ ), intrinsically safe

2

3

4

5

6

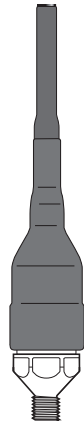

Thread mount

Accelerometer w/  
IP 68 option

Vibration acceleration



Bearing condition



Pump cavitation



0044

**IP 68 (Option)**

A

### Application

These accelerometers are suitable for vibration measurements on rotating machinery. The accelerometer series VIB 6.125 can additionally be used for shock pulse measurements on roller bearings and for cavitation measurements in pumps.

In combination with the IP 68 option the accelerometers can be used under water and in hot and chemical aggressive fluids. The signal acquisition and processing is carried out with a condition monitoring system from PRÜFTECHNIK (e.g. VIBNODE, VIBROWEB,...).

The accelerometer of the series VIB 6.125 IDEX and VIB 6.129 IDEX are gas and dust explosion-proof. They are suitable for use with dusts having a minimum ignition temperature for 5 mm layers of not less than 210 °C. The maximum ambient temperature is 80°C.

### Notes on intrinsic safety

The accelerometers of the series VIB 6.125 IDEX and VIB 6.129 IDEX may only be connected to designated devices with the following interface parameters:

$$U_{\max} = 24\text{V}$$

$$P_{\max} = 300\text{mW}$$

$$C_i = 15\text{nF}$$

$$L_i = \text{negligible small}$$

The following documents must be considered:

- EC type examination certificate TÜV 02 ATEX 1865
- 1st supplement dated from 01.03.2007
- 2nd supplement dated from 22.06.2011

Additionally the installation notes for hazardous areas annexed in this catalog must be observed.

### Installation accessories

Mounting tools for screw threads:

VIB 8.693 M8 screw tap

VIB 8.694 90° countersink bit

Mounting adapters for M8 screw threads:

VIB 3.474 Screwed adapter to M16

VIB 3.475 Screwed adapter to M20

VIB 8.772 Screwed adapter to M10

VIB 3.411 -, w/ locking nut to M8

VIB 3.412 -, w/ locking nut to M10

VIB 3.413 -, w/ locking nut to M12

Extension post for M8 screw threads:

VIB 8.586 length: 55 mm

VIB 8.587 length: 95 mm

VIB 8.588\* length: 170 mm

VIB 8.589 length: 35 mm

\* only for shock pulse measurements!

IP 68 option for use in liquid media:

VIB 6.760 IP 68 option, oil-resistant, long version

VIB 6.761 IP 68 option, oil-resistant, short version



## Technical data

PARAMETER		VIB 6.125 RIP	VIB 6.125 IDEX	VIB 6.129 IP	VIB 6.129 IDEX
Measurement	Signaling system	Current LineDrive, 3.5 mA closed current with superposed AC signal			
	Transmission factor	1,0 $\mu\text{A}/\text{ms}^2$ (Reference: 159 Hz; 25 °C) $\pm$ 3%		5.35 $\mu\text{A}/\text{ms}^2$ (Reference: 159 Hz; 25 °C) $\pm$ 4%	
	Frequency range $\pm$ 5%	2 Hz ... 8 kHz		2 Hz ... 4 kHz	
	$\pm$ 10%	1 Hz ... 12 kHz		1 Hz ... 6 kHz	
	$\pm$ 3dB	1 Hz ... 20 kHz		0.3 Hz ... 10 kHz	
	Resonance frequency	36 kHz		17 kHz; > 20 dB damped	
	Linearity range $\pm$ 10%	$\pm$ 961 $\text{ms}^{-2}$		$\pm$ 450 $\text{ms}^{-2}$	
	Temperature range, w/ Rayolin cable	-30 °C ... +125 °C	--	-30 °C ... +125 °C	--
	w/ PVC cable	--	-30 °C ... +80 °C	--	-30 °C ... +80 °C
w/ Teflon cable	-30 °C ... +135 °C	--	-30 °C ... +135 °C	--	
Electrical	Power requirement	> 10 mA / 7-18 VDC			
	Transverse sensitivity	< 5% at 10 kHz			
	Temperature sensitivity	< 0.05 $\text{ms}^{-2}/\text{K}$		< 0.01 $\text{ms}^{-2}/\text{K}$	
	Magnetic sensitivity	< 5 $\text{ms}^{-2}/\text{T}$ (at 50 Hz)		< 1 $\text{ms}^{-2}/\text{T}$ (at 50 Hz)	
	Base strain sensitivity	< 0.1 $\text{ms}^{-2}/\mu\text{m}/\text{m}$			
	Electrical noise, rms	< 0.01 $\text{ms}^{-2}$ from 2 Hz		< 0.002 $\text{ms}^{-2}$ from 2 Hz	
	Output impedance	> 1 MOhm		> 300 kOhm	
	Insulation	> 10 <sup>9</sup> MOhm			
Mechanical	Case material	Stainless steel VA 1.4571, chemical resistant			
	Environmental protection	IP 65 w/ cable, IP 68 w/ option VIB 6.760 / VIB 6.761			
	Cable connection	TNC socket			
	Shock limit	< 250 $\text{kms}^{-2}$		< 50 $\text{kms}^{-2}$	
	Weight	40 g		43 g	
	Installation height, w/ IP 68 option VIB 6.760	> 140 mm			
	Installation height, w/ IP 68 option VIB 6.761	> 120 mm			
Mounting	M8 thread				
EX	Marking, gas explosion protection	--	Ex II 2 G Ex ib IIC T4	--	Ex II 2 G Ex ib IIC T4
	Marking, dust explosion protection	--	Ex II 2 D Ex ib IIIB T <sub>5</sub> 187°C	--	Ex II 2 D Ex ib IIIB T <sub>5</sub> 187°C

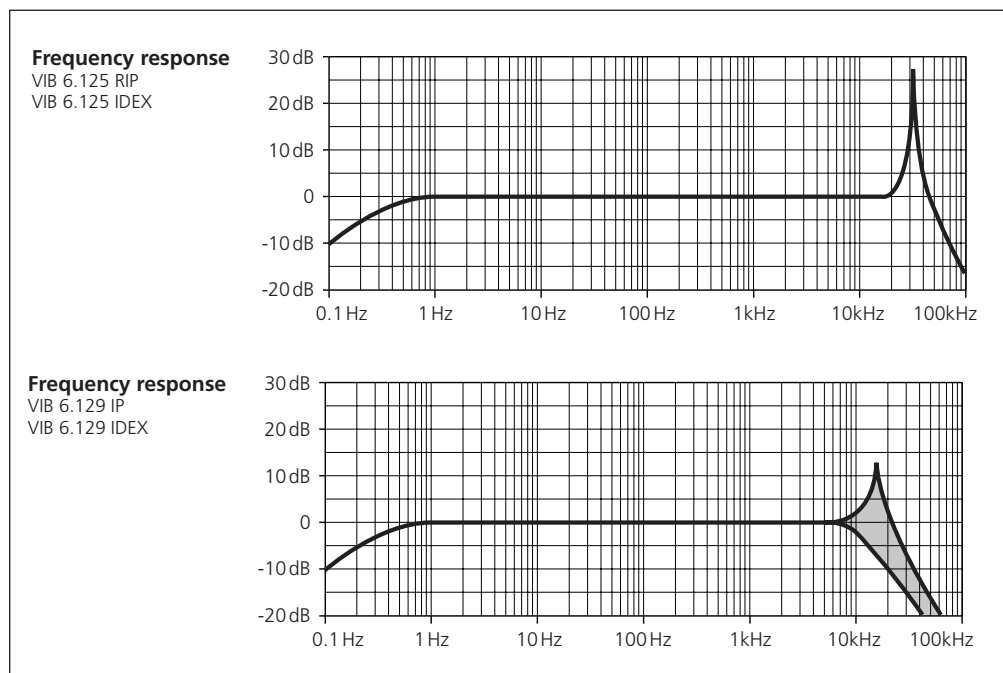

C

## Mini accelerometers

1

VIB 6.202-3: Mini accelerometer with RG 174 cable, 3 meters

VIB 6.202-6: Mini accelerometer with RG 174 cable, 6 meters

VIB 6.203-3: Mini accelerometer with Spec 44 cable, 3 meters

VIB 6.203-6: Mini accelerometer with Spec 44 cable, 6 meters

2

3

4

5

6

A

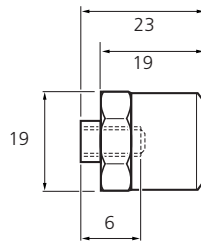
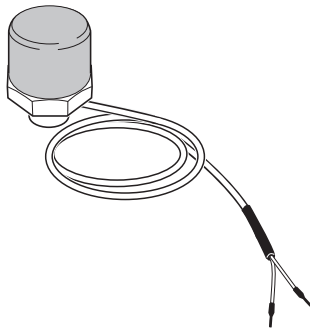

Dimensions in mm

size 19



Vibration acceleration



Bearing condition



Pump cavitation

### Application

These accelerometers are suitable for vibration measurements up to 10 kHz on machinery with rotational speeds above 120 min<sup>-1</sup>, for shock pulse measurements on roller bearings and for cavitation measurements in pumps.

The compact design and the position of the cable, which is passed through the base, reduces the installation space required for this type of accelerometers considerably.

The accelerometers are mainly used for continuous machine condition monitoring in an industrial environment. The signal acquisition and processing is carried out with a condition monitoring system from PRÜFTECHNIK (e.g. VIBNODE, VIBROWEB,...).

### Installation accessories

VIB 3.417-M5	M5 screwed adapter for mini accelerom.
VIB 3.417-M6	M6 screwed adapter for mini accelerom.
VIB 3.418	Adhesive adapter for mini accelerom.
VIB 3.423	Magnetic holder for flat surfaces

Installation material for adhesive mount:  
2-component adhesive (e.g. WEICON HB 300).

Installation material for sensor cable  
VIB 93025 TNC plug for RG 174 cable  
VIB 81015 Protective sleeve for RG 174 cable

### Extending the sensor cable

To extend the sensor cable installed, use shielded cables (coaxial or triaxial) that are electrically connected in a junction box (e.g. VIB 6.776).

### Mounting types

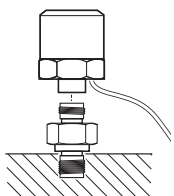

Screwed adapter  
VIB 3.417-M5  
VIB 3.417-M6

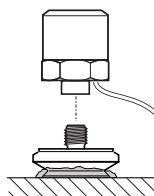

Adhesive adapter  
VIB 3.418

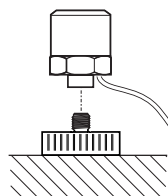

Magnetic adapter  
VIB 3.423

### Accessories for RG 174 cable



TNC plug  
VIB 93025



TNC plug + protective sleeve  
VIB 93025 + VIB 81015

## Technical data

PARAMETER		VIB 6.202	VIB 6.203
Measurement	Signaling system	Current Line Drive; $3.5 \pm 1.5$ mA closed current with superposed AC signal	
	Transmission factor $\pm 10\%$	$1.0 \mu\text{A}/\text{ms}^{-2}$ (Reference: 159 Hz; 25 °C)	
	Frequency range $\pm 10\%$	4 Hz ... 8 kHz	
	$\pm 3\text{dB}$	2 Hz ... 10 kHz	
	Resonance frequency	30 kHz	
	Linearity range $\pm 10\%$	$\pm 961 \text{ ms}^{-2}$ ( $\pm 98\text{g}$ )	
	Temperature range	$-30 \text{ °C} \dots +80 \text{ °C}$	$-30 \text{ °C} \dots +120 \text{ °C}$
Electrical	Power requirement	$> 10 \text{ mA} / 7\text{-}18 \text{ VDC}$	
	Temperature sensitivity	$< 0.08 \text{ ms}^{-2}/\text{K}$	
	Electrical noise, rms	$< 0.1 \text{ ms}^{-2}$ ab 2 Hz	
	Output impedance	$> 250 \text{ k}\Omega$	
Mechanical	Case material	Stainless steel VA 1.4305 / Grivory HTV (resistant amongst others to diesel, crude oil, hydraulic and engine oil, lubricants, tar, turpentine)	
	Environmental protection	IP 65 (w/ cable)	
	Shock limit	$< 250 \text{ kms}^{-2}$	
	Weight	22 g	
	Dimensions	see figure	
	Mounting	Adapter w/ UNF 1/4 thread	
	Connection cable		
	Specification	Coaxial, RG 174/U	Coaxial, Raychem Spec. 44
	Diameter	2.8 mm	2.4 mm
	Material	PVC - Polyvinylchloride	PVDF - Polyvinylidenfluoride: highly resistant to many acids, alkalis, hydrocarbon solvents, fuels, lubricants, water, and many missile fuels and oxidizers
Protective sleeve, material	EVA, non halogen line Temp.range: $-40\text{ °C} \dots +70\text{ °C}$	---	

C

1

2

3

4

5

6

A

Frequency response - VIB 6.202 / VIB 6.203

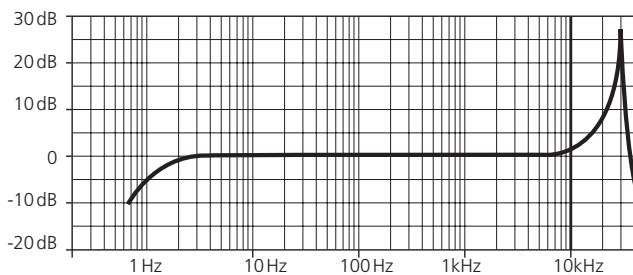

C

**VIB 7.205-2,9: VIBCONNECT RF sensor**

1

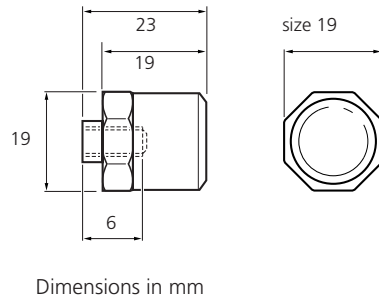
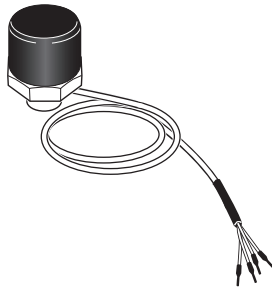

Vibration acceleration



Temperature

2

3

4

5

**Application**

This accelerometer is suitable for vibration measurements up to 10 kHz on machinery with rotational speeds above 300 min<sup>-1</sup> and for temperature measurements.

6

The compact design and the position of the cable reduces the installation space required for this type of accelerometers considerably.

A

The accelerometer is used together with the wireless CMS VIBCONNECT RF for continuous machine condition monitoring in an industrial environment.

**Installation accessories**

- VIB 3.417-M5 M5 screwed adapter for mini accelerom.
- VIB 3.417-M6 M6 screwed adapter for mini accelerom.
- VIB 3.418 Adhesive adapter for mini accelerom.
- VIB 3.423 Magnetic holder for flat surfaces

Installation material for adhesive mount:  
2-component adhesive (e.g. WEICON HB 300).

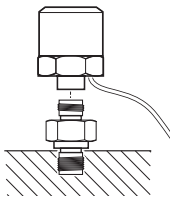
**Mounting types**

Screwed adapter  
VIB 3.417-M5  
VIB 3.417-M6

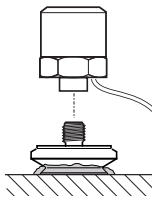

Adhesive adapter  
VIB 3.418

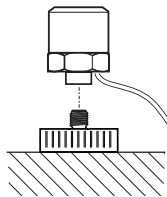

Magnetic adapter  
VIB 3.423

## Technical data

PARAMETER		VIB 7.205-2,9
Measurement, Vibration	Sensortype	Combined accelerometer / temperature sensor with low power consumption
	Output $\pm 10\%$	3.5 mV / ms <sup>2</sup>
	Max. measuring range $\pm 10\%$	500 m/s <sup>2</sup> rms
	Offset	2.5 VDC
	Frequency range $\pm 10\%$	10 Hz ... 8 kHz
	$\pm 3\text{dB}$	5 Hz ... 10 kHz
Temperature	Resonance frequency	23 kHz (Resonance rise: 9 dB)
	Temperature measuring range	-40 °C ... +85 °C
	Output $\pm 3\%$	-5.5 mV/K
Electrical	Benchmark	898 mV at 25°C
	Power requirement	5 VDC / < 0.5 mA
	Temperature sensitivity	< 0.08 ms <sup>2</sup> /K
General	Electrical noise, rms	< 0.0015 ms <sup>2</sup> / Hz <sup>1/2</sup> from 30 Hz to 10 kHz < 0.005 m/s <sup>2</sup> at 5 Hz
	Case material	Stainless steel VA 1.4305 / Grivory HTV (resistant amongst others to diesel, crude oil, hydraulic and engine oil, lubricants, tar, turpentine)
	Environmental protection	IP 65
	Shock limit	< 250 kms <sup>2</sup>
	Relative humidity	< 95%, non-condensed
	Weight	22 g
	Dimensions	see figure
	Mounting	Adapter w/ UNF 1/4 thread
	Connection cable	
	Specification	3 wire, shielded
	Outer diameter	2.9 mm
	Length	2.9 m
Material	ETFE	
Chemical resistance	Highly resistant to acid, alkali, oil, fuel	

Frequency response - VIB 7.205-2,9

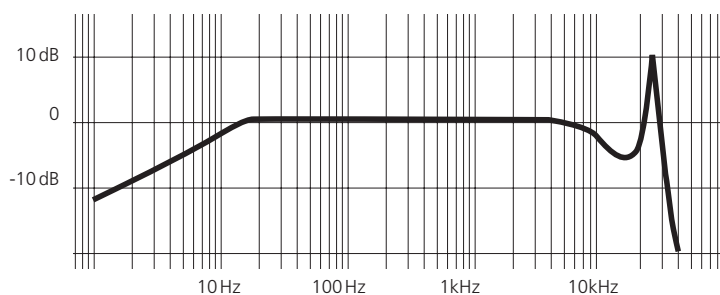

Connection cable, color code:

VIB 7.205-2,9	
Wire color	Function
Red	Power, 5 VDC
Black	Temperature signal
White	Vibration signal
Shield	GND

C

## Hybrid triaxial accelerometers for VIBGUARD

1

VIB 6.215: Hybrid triaxial accelerometer for VIBGUARD 1 Hz ... 10 kHz (Z)

VIB 6.216: Hybrid triaxial accelerometer for VIBGUARD 0.1 Hz ... 10 kHz (Z)

2

3

4

5

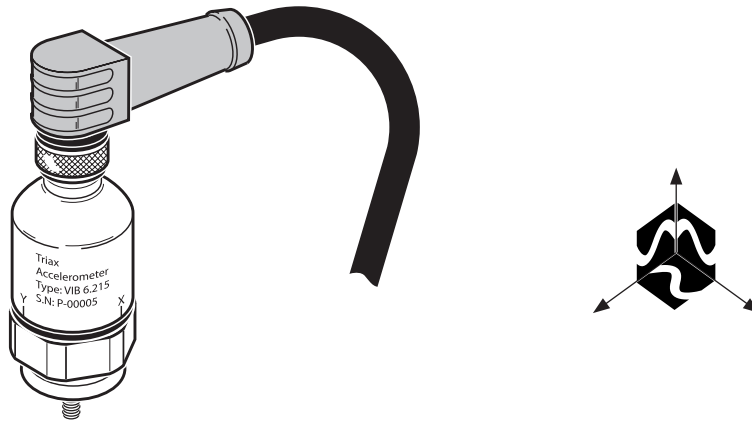

6

### Application

Detection of low frequency mechanical vibration in three axes, such as on wind turbines.

A

### Function

Vibrations in the X and Y directions are detected by a MEMS sensor\*. A PRUFTECHNIK accelerometer measures vibrations in the Z direction.

\*MEMS: MicroElectroMechanical System

### Mounting

The sensor is glued onto the machine. The orientation of the measurement axis has to be observed during installation. The positions of the X and Y axes are labeled on the sensor housing. The Z-axis points onto the object.

### Connection

The connection to the VIBGUARD condition monitoring system is carried out with a cable available as an accessory.

### Accessories

- |              |  |
|--------------|--|
| VIB 3.575-10 | Connection cable for triax accelerometer VIB 6.215, 10 m |
| VIB 3.575-20 | Connection cable for triax accelerometer VIB 6.215, 20 m |

**Technical data**

PARAMETER		VIB 6.215	VIB 6.216	
Measurement	Signaling system	X / Y Z	Voltage ICP	
	Measuring range (0-p)	X / Y Z	19.6 m/s <sup>2</sup> 400 m/s <sup>2</sup>	
	Transmission factor	X / Y Z	67 mV/ms <sup>2</sup> , ± 6% @ 159 Hz 20 mV/ms <sup>2</sup> , ± 3% @ 159 Hz	
	Frequency range	X / Y Z	0 Hz ... 1 kHz (± 3dB) 1 Hz ... 10 kHz (± 3dB)	0 Hz ... 1 kHz (± 3dB) 0.1 Hz ... 10 kHz (± 3dB)
	Resonance frequency	X / Y Z	2.5 kHz 28 kHz	
	Grav. acceleration voltage	X / Y	± 660 mV, ± 6%	
	Max. deviation from linear average after 360° rotation	X / Y	± 2% of meas. value	
	Inaccuracy of axis labeling		< ± 5°	
	Temperature sensitivity	X Y Z	AC / DC: -0.03% of meas. value/K AC: -0.03% of m.v./K; DC: +0.03% of m.v./K 0.1% of m.v./K	
	Temperature leap sensitivity	X / Y Z	0.015 ms <sup>-2</sup> /K 3.1 ms <sup>-2</sup> /K	
	Transverse sensitivity		< 5%	
	Electrical	Sound sensitivity	X / Y Z	< 1.5 ms <sup>-2</sup> /mPa < 0.15 ms <sup>-2</sup> /mPa
Power supply		X / Y Z	MEMS electronics via Z channel 24 VDC / 3-10 mA, ± 10%	
Noise		X / Y	0.0005 ms <sup>-2</sup> /(Hz) <sup>1/2</sup> for 1 Hz ... 1 kHz	0.0005 ms <sup>-2</sup> /(Hz) <sup>1/2</sup> for 0.1 Hz ... 1 kHz
Noise		Z	0.005 ms <sup>-2</sup> at 1 Hz 0.0005 ms <sup>-2</sup> /(Hz) <sup>1/2</sup> for 10 Hz ... 10 kHz	
Output impedance			100 Ohm	
Environment	Output bias	X / Y Z	1.65 VDC 10.5-13.5 VDC	
	Temperature range		-40°C ... +85 °C	
	Relative humidity		95%, non-condensing	
	Chemical resistance, cable		Oil, alcohol	
	Environmental protection, w/ cable		IP 65	
Mechanical	Shock limit		< 100 kms <sup>-2</sup> (10000 g)	
	Case material		Stainless steel 1.4305	
	Mounting		Adhesive mount	
	Connection		M12 plug, 4 wire, A coded	
Weight		62 g		

**Response curves**

VIB 6.215: Frequency response Z axis

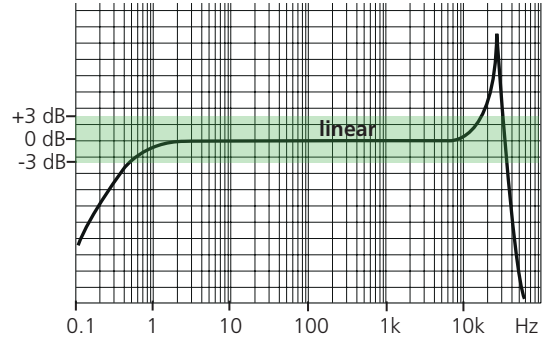

VIB 6.216: Frequency response Z axis

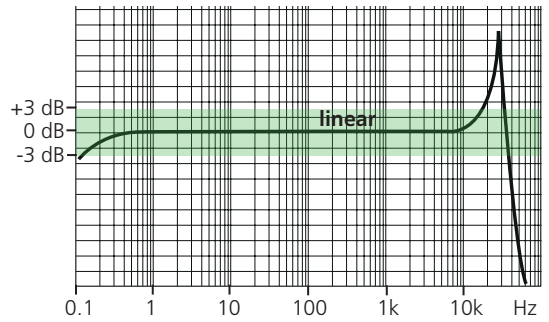

VIB 6.215 / VIB 6.216: Frequency response X axis (green); Y axis (brown)

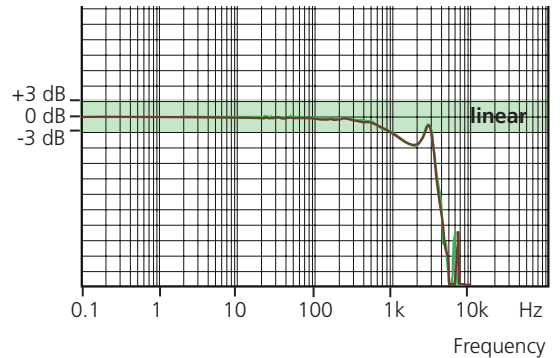

**Dimensions**

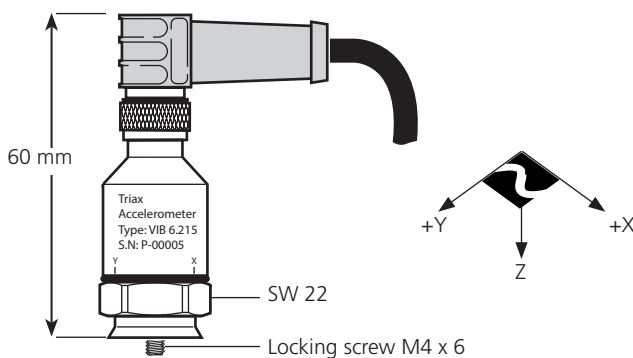

**Pin allocation, sensor connection socket:**

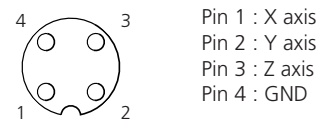

**Color code, connection cable:**

- Wire 1 : brown, bn
- Wire 2 : blue, bu
- Wire 3 : black, bk
- Wire 4 : Shield

## VIBROTECTOR vibration transmitters

VIB 5.731 : VIBROTECTOR vibration transmitter, 10 Hz - 1 kHz

VIB 5.736 : VIBROTECTOR vibration transmitter, 2 Hz - 1 kHz

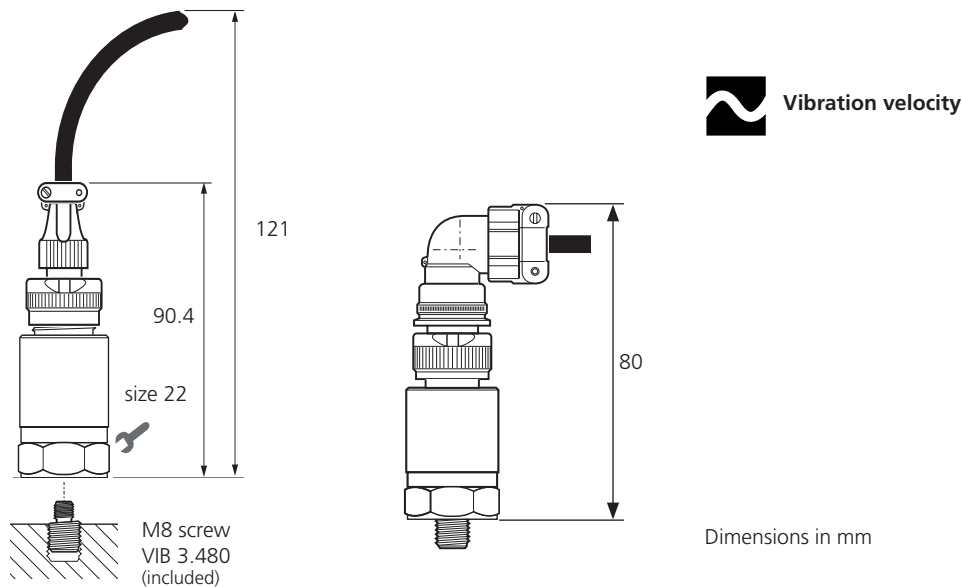

### Application

The VIBROTECTOR vibration transmitter measures vibration velocity and is used for the continuous monitoring of absolute machine vibrations. The output signal (4-20mA) is output for analysis and alarm directly on the control system.

### Installation accessories

Mounting tools for screw threads:

- VIB 8.693 M8 screw tap
- VIB 8.694 90° countersink bit

Mounting adapters for VIBROTECTOR:

- VIB 3.437 Screwed adapter to M8-90°
- VIB 3.438 Screwed adapter to M8 flat
- VIB 3.439 Screwed adapter to M5 flat
- VIB 3.480 M8 screw
- VIB 3.433 Adhesive adapter

Installation material for adhesive mount:

2-component adhesive (e.g. WEICON HB 300).

Connection cables

- VIB 5.740-X Connection cable (silicone) w/ straight plug, X meters long.
- VIB 5.741-X Connection cable (silicone) w/ angled plug, X meters long.
- VIB 5.745-L Connection cable (PUR) w/ angled plug, X meters long.
- VIB 5.746-L Connection cable (PUR) w/ straight plug, L meters long.

### Mounting VIBROTECTOR

- Drill the mounting hole as shown in the graphics.
- Clean and smooth the area around the mounting hole (Abrasive paper, type 220).
- Clean both contact surfaces with solvent.
- Cover one of the dried surfaces with a thin film of LOCTITE 243 for better signal transmission.
- Screw in the VIBROTECTOR (3-7Nm!).

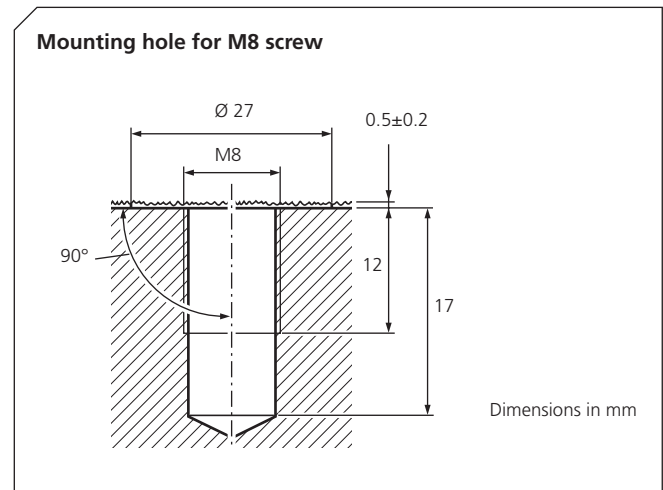



**Technical data**

PARAMETER		VIB 5.731	VIB 5.736
Measurement	Output signal	Current level (4-20mA)	
	Measurement range (RMS) ±2%	≤ 20 mm/S (Ref.: 159 Hz)	
	Frequency range ± 10%	10 Hz ... 1 kHz	2 Hz ... 1 kHz
	Temperature range	-30 °C ... +80 °C	
	Temperature sensitivity	- 0.4 µA/K	
Electrical	Supply voltage (loop power)	24 VDC (±5%)	
	Loop resistance	90 ... 360 Ohm	
	Insulation	complete	
Mechanical	Case material	Stainless steel VA 1.4305	
	Environmental protection	IP 67 (IP 68 w/ special cable)	
	Shock limit	50 km/s <sup>2</sup>	
	Connector type	Cable connector, 2 pin (Cannon, Mil-C5015)	
	Weight	80 g	
	Mounting	M8 thread	

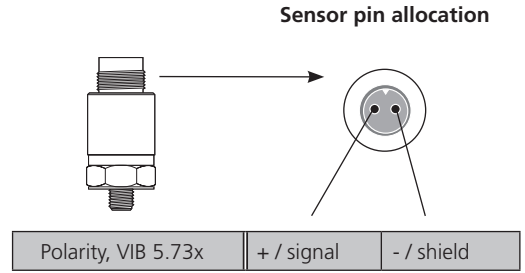

**Frequency response**

VIBROTECTOR, 10 Hz - 1 kHz (VIB 5.731)

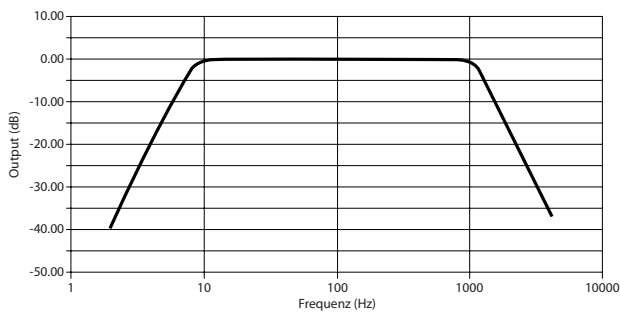

VIBROTECTOR, 2 Hz - 1 kHz (VIB 5.736)

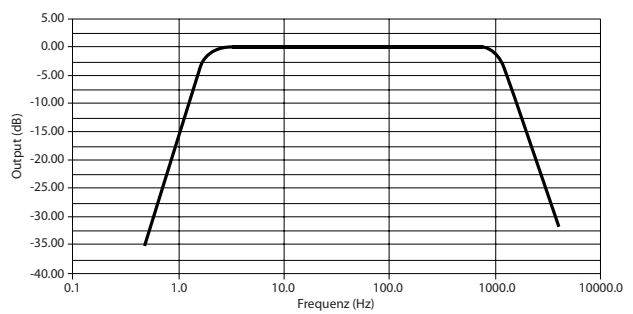

**Connecting VIBROTECTOR to PCS, PLC**

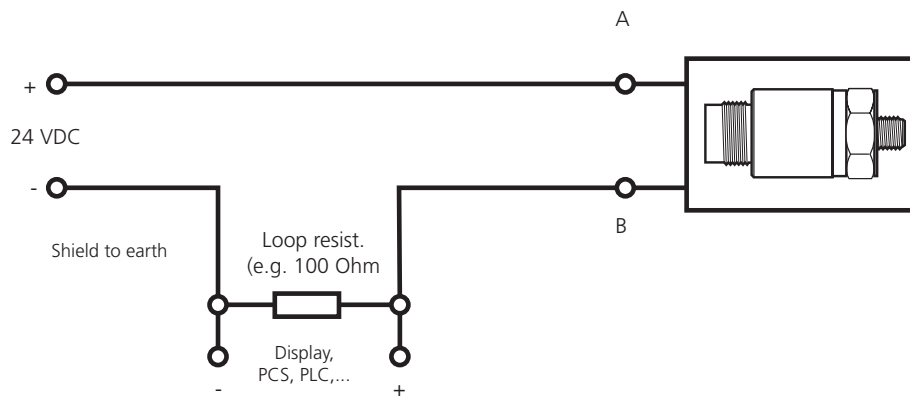

C

## Industrial accelerometers for very low-speed machinery ( $n > 6 \text{ min}^{-1}$ )

1

VIB 6.172 : ICP-type accelerometer for very low-speed machinery 0.1 Hz - 10 kHz, Mil connector

VIB 6.195 : CLD accelerometer for very low-speed machinery 0.1 Hz - 10 kHz, Mil connector

2

3

4

5

6

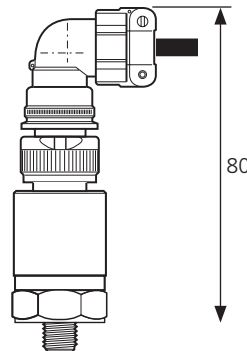
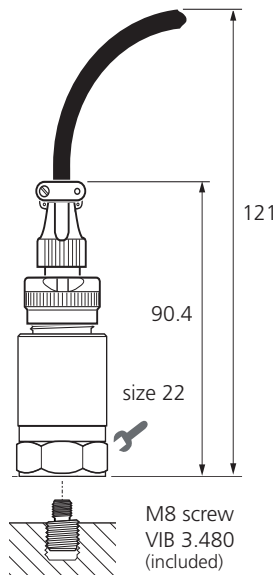

### Vibration acceleration

CLD: Current Line Drive

ICP: Integrated Circuit Piezoelectric

Dimensions in mm

A

### Application

These accelerometers are used for the measurement of very slowly rotating machinery components such as the main bearings of a wind turbine.

### Installation and connection

Permanent mounting using a threaded or adhesive adapter. The accelerometer is connected to the measuring device with a screened twisted pair cable.

### Installation accessories

Mounting tools for screw threads:

- VIB 8.693 M8 screw tap
- VIB 8.694 90° countersink bit

Mounting adapters for VIB 6.195 / VIB 6.172:

- VIB 3.437 Screwed adapter to M8-90°
- VIB 3.438 Screwed adapter to M8 flat
- VIB 3.439 Screwed adapter to M5 flat
- VIB 3.480 M8 screw
- VIB 3.433 Adhesive adapter
- VIB 3.423 Magnetic holder for flat surfaces

Installation material for adhesive mount:  
2-component adhesive (e.g. WEICON HB 300).

Connection cables

- VIB 5.740-X Connection cable (silicone) w/ straight plug, X meters long.
- VIB 5.741-X Connection cable (silicone) w/ angled plug, X meters long.
- VIB 5.745-L Connection cable (PUR) w/ angled plug, X meters long.

VIB 5.746-L Connection cable (PUR) w/ straight plug, L meters long.

Connecting VIBXPert II via sensor cable VIB 5.436 plus:  
VIB 5.449-ICP Cable adapter for ICP-type accelerometer VIB 6.172

VIB 5.449-CLD Cable adapter for CLD-type accelerometer VIB 6.195

### Mounting

- Drill the mounting hole as shown in the graphics.
- Clean and smooth the area around the mounting hole (Abrasive paper, type 220).
- Clean both contact surfaces with solvent.
- Cover one of the dried surfaces with a thin film of LOCTITE 243 for better signal transmission.
- Screw in the accelerometer (3-7Nm!).

#### Mounting hole for M8 screw

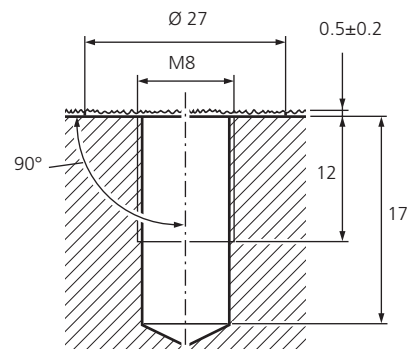

Dimensions in mm

## Technical data

PARAMETER		VIB 6.172	VIB 6.195
Measurement	Signaling system	ICP	Current Line Drive; 3.5 mA closed current w/ superposed AC signal
	Transmission factor $\pm 4\%$	100 mV/g (Ref.: 159 Hz; 25 °C)	5.35 $\mu\text{A}/\text{ms}^2$ (Ref.: 159 Hz; 25 °C)
	Frequency range $\pm 3\text{dB}$	0.1 Hz ... 10 kHz	
	Resonance frequency	17 kHz; > 10 dB damped	17 kHz; > 20 dB damped
	Linearity range	< 70 g (r.m.s.) $\pm 1\%$	$\pm 450 \text{ ms}^2 \pm 10\%$
	Temperature range	-40 °C ... +120 °C	-30 °C ... +80 °C
Electrical	Power requirement	2 - 10 mA / 24 VDC ( $\pm 10\%$ )	> 10 mA / 7-18 VDC
	Bias, DC output	12 V DC ( $\pm 0.5\text{V}$ )	--
	Grounding	insulated from machine ground, internal shielding	--
	Transverse sensitivity	< 5% at 5 kHz	< 5% at 10 kHz
	Temperature sensitivity	< 0.15 g/K	< 0.01 $\text{ms}^2/\text{K}$
	Magnetic sensitivity	< 0.1 g/T (at 50 Hz)	< 1 $\text{ms}^2/\text{T}$ (at 50 Hz)
	Base strain sensitivity	< 0.001 g/ $\mu\text{m}/\text{m}$	< 0.1 $\text{ms}^2/\mu\text{m}/\text{m}$
	Acoustic sensitivity (130 dB)	0.0004 g	---
	Electrical noise, (0.1 Hz - 20 kHz)	< 0.0005 g from 0.1 Hz	< 0.002 $\text{ms}^2$ from 2 Hz
	Output impedance	< 10 Ohm	> 300 kOhm
Mechanical	Case material	Stainless steel VA 1.4305	
	Environmental protection	IP 67 (w/ cable)	
	max. Shock limit	5000 g	--
	Connector type	Cable connector, 2 pole (Mil-C5015)	
	Weight	85 g	
	Dimensions	see previous page	
	Mounting	M8 thread	

### Frequency response - VIB 6.172

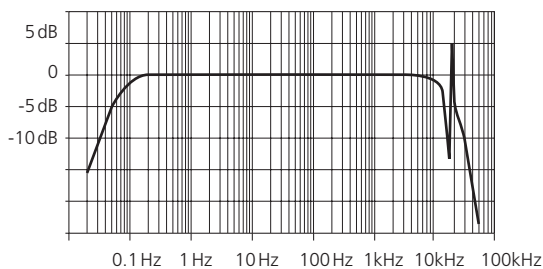

### Frequency response - VIB 6.195

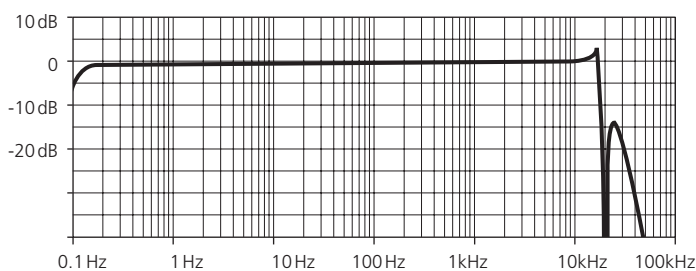

### Sensor pin allocation

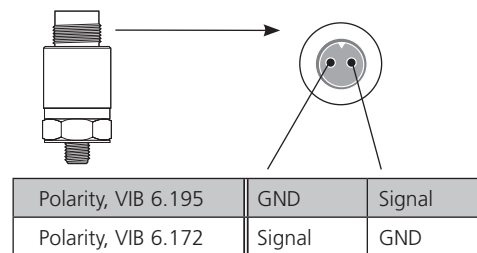

C

## Industrial accelerometers for standard machinery ( $n > 60 \text{ min}^{-1}$ ), intrinsically safe

1

VIB 6.102 DEX : Industrial accelerometer for standard machinery, adhesive mount, intrinsically safe

VIB 6.122 DEX : Industrial accelerometer for standard machinery, M8 thread mount, intrinsically safe

VIB 6.132 DEX : Industrial accelerometer for standard machinery, UNC 5/16 thread mount, intrinsically safe

2

3

4

5

6

A

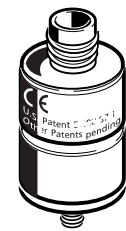

Adhesive mount



Thread mount



Vibration acceleration



Bearing condition



Pump cavitation



CE 0044

### Application

These accelerometers are suitable for vibration measurements up to 20 kHz on machinery with rotational speeds above  $60 \text{ min}^{-1}$ , for shock pulse measurements on roller bearings and for cavitation measurements in pumps.

The accelerometers are mainly used for continuous machine condition monitoring in a hazardous industrial environment. The signal acquisition and processing is carried out with a condition monitoring system from PRÜFTECHNIK (e.g. VIBNODE, VIBROWEB,...).

The accelerometers are gas and dust explosion-proof. They are suitable for use with dusts having a minimum ignition temperature for 5 mm layers of not less than  $210 \text{ }^\circ\text{C}$ .

### Notes on intrinsic safety

The accelerometers of the series VIB 6.1xx DEX may only be connected to designated devices with the following interface parameters:

$$\begin{aligned} U_{\max} &= 24\text{V} \\ P_{\max} &= 300\text{mW} \\ C_i &= 15\text{nF} \\ L_i &= \text{negligible small} \end{aligned}$$

The following documents must be considered:

- EC type examination certificate TÜV 02 ATEX 1865
- 1st supplement dated from 01.03.2007
- 2nd supplement dated from 22.06.2011

Additionally the installation notes for hazardous areas annexed in this catalog must be observed.

### Installation accessories

Mounting tools for screw threads:

VIB 8.693	M8 screw tap
VIB 8.696	UNC 5/16 screw tap
VIB 8.694	90° countersink bit

Mounting adapters for M8 screw threads:

VIB 3.474	Screwed adapter to M16
VIB 3.475	Screwed adapter to M20
VIB 8.772	Screwed adapter to M10
VIB 3.411	-, w/ locking nut to M8
VIB 3.412	-, w/ locking nut to M10
VIB 3.413	-, w/ locking nut to M12
VIB 3.431	-, w/ adhesive mount

Mounting adapters for UNC 5/16 screw threads:

VIB 3.414	Screwed ad. w/ locking nut to UNC 5/16
VIB 3.415	-, w/ locking nut to UNC 3/8 - 16
VIB 3.416	-, w/ locking nut to UNC 1/2 - 13
VIB 3.432	-, w/ adhesive mount

Extension post for M8 screw threads:

VIB 8.586	length: 55 mm
VIB 8.587	length: 95 mm
VIB 8.588*	length: 170 mm
VIB 8.589	length: 35 mm

Extension post for UNC 5/16 screw threads:

VIB 8.590	length: 2 1/8"
VIB 8.591	length: 3 3/4"
VIB 8.592*	length: 6 5/8"

\* only for shock pulse measurements!

Installation material for adhesive mount:  
2-component adhesive (e.g. WEICON HB 300).

## Technical data

PARAMETER		VIB 6.102 DEX	VIB 6.122 DEX	VIB 6.132 DEX
Measurement	Signaling system	Current LineDrive, 3.5 mA closed current with superposed AC signal		
	Transmission factor ± 3%	1.0 $\mu\text{A}/\text{ms}^{-2}$ (Reference: 159 Hz; 25 °C)		
	Frequency range ± 5%	2 Hz ... 8 kHz		
	± 10%	1 Hz ... 12 kHz		
	± 3dB	1 Hz ... 20 kHz		
	Resonance frequency	36 kHz		
	Linearity range ± 10%	± 961 $\text{ms}^{-2}$		
Electrical	Temperature range, w/ Rayolin cable	-30 °C ... +80 °C		
	Power requirement	> 10 mA / 7-18 VDC		
	Transverse sensitivity	< 5% at 10 kHz		
	Temperature sensitivity	< 0.05 $\text{ms}^{-2}/\text{K}$		
	Magnetic sensitivity	< 5 $\text{ms}^{-2}/\text{T}$ (at 50 Hz)		
	Base strain sensitivity	< 0.1 $\text{ms}^{-2}/\mu\text{m}/\text{m}$		
	Electrical noise, rms	< 0.01 $\text{ms}^{-2}$ from 2 Hz		
	Output impedance	> 1 MOhm		
Mechanical	Insulation	> 10 <sup>9</sup> MOhm		
	Case material	Stainless steel VA 1.4305		
	Environmental protection	IP 65 (w/ cable)		
	Cable connection	TNC socket		
	Shock limit	< 250 $\text{kms}^{-2}$		
	Weight	40 g		
	Installation height A (see below)			
	w/ coaxial cable & straight TNC plug	> 119 mm	> 115 mm	
	Mounting	Adhesive	M8 thread	UNC 5/16 thread
EX	Marking, gas explosion protection	II 2 G Ex ib IIC T4		
	Marking, dust explosion protection	II 2 D Ex ib IIIB T <sub>5</sub> 187°C		

### Dimensions

in mm

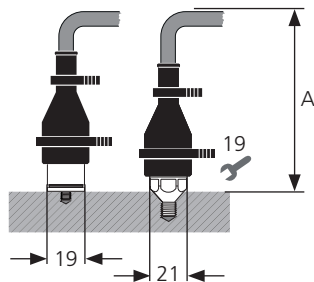

### Frequency response

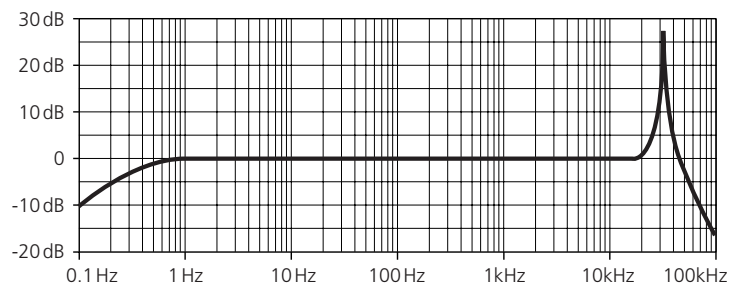

C

**VIB 6.152 DEX: Industrial accelerometer, low sensitivity, intrinsically safe**

1

0,1  $\mu\text{A}/\text{ms}^{-2}$ 

M8 thread



Vibration acceleration



Bearing condition



Pump cavitation



CE 0044

2

3

4

5

**Application**

This accelerometer is suitable for vibration measurements up to 20 kHz on machinery with rotational speeds above 5000  $\text{min}^{-1}$ , for shock pulse measurements on roller bearings and for cavitation measurements in pumps.

6

The accelerometer is mainly used for continuous machine condition monitoring in a hazardous industrial environment. The signal acquisition and processing is carried out with a condition monitoring system from PRÜFTECHNIK (e.g. VIBNODE, VIBROWEB,...).

A

The accelerometer is gas and dust explosion-proof. It is suitable for use with dusts having a minimum ignition temperature for 5 mm layers of not less than 210 °C.

**Notes on intrinsic safety**

The accelerometers of the series VIB 6.1xx DEX may only be connected to designated devices with the following interface parameters:

$$\begin{aligned} U_{\max} &= 24\text{V} \\ P_{\max} &= 300\text{mW} \\ C_i &= 15\text{nF} \\ L_i &= \text{negligible small} \end{aligned}$$

The following documents must be considered:

- EC type examination certificate TÜV 02 ATEX 1865
- 1st supplement dated from 01.03.2007
- 2nd supplement dated from 22.06.2011

Additionally the installation notes for hazardous areas annexed in this catalog must be observed.

**Installation accessories**

Mounting tools for screw threads:

- |           |                     |
|-----------|---------------------|
| VIB 8.693 | M8 screw tap        |
| VIB 8.694 | 90° countersink bit |

Mounting adapters for M8 screw threads:



- |           |                          |
|-----------|--------------------------|
| VIB 3.474 | Screwed adapter to M16   |
| VIB 3.475 | Screwed adapter to M20   |
| VIB 8.772 | Screwed adapter to M10   |
| VIB 3.411 | -, w/ locking nut to M8  |
| VIB 3.412 | -, w/ locking nut to M10 |
| VIB 3.413 | -, w/ locking nut to M12 |
| VIB 3.431 | -, w/ adhesive mount     |

Extension post for M8 screw threads:

- |            |                |
|------------|----------------|
| VIB 8.586  | length: 55 mm  |
| VIB 8.587  | length: 95 mm  |
| VIB 8.588* | length: 170 mm |
| VIB 8.589  | length: 35 mm  |
- \* only for shock pulse measurements!

Installation material for adhesive mount:  
2-component adhesive (e.g. WEICON HB 300).

## Technical data

PARAMETER		VIB 6.152 DEX
Measurement	Signaling system	Current LineDrive, 3.5 mA closed current with superposed AC signal
	Transmission factor $\pm 3\%$	0.1 $\mu\text{A}/\text{ms}^2$ (Reference: 159 Hz; 25 °C)
	Frequency range $\pm 5\%$	2 Hz ... 8 kHz
	$\pm 10\%$	1 Hz ... 12 kHz
	$\pm 3\text{dB}$	1 Hz ... 20 kHz
	Resonance frequency	36 kHz
	Linearity range $\pm 10\%$	$\pm 961 \text{ ms}^{-2}$
Electrical	Temperature range, w/ Rayolin cable	-30 °C ... +80 °C
	Power requirement	> 10 mA / 7-18 VDC
	Transverse sensitivity	< 5% at 10 kHz
	Temperature sensitivity	< 0.5 $\text{ms}^{-2}/\text{K}$
	Magnetic sensitivity	< 50 $\text{ms}^{-2}/\text{T}$ (at 50 Hz)
	Base strain sensitivity	< 1 $\text{ms}^{-2}/\mu\text{m}/\text{m}$
	Electrical noise, rms	< 0.0005 $\text{ms}^{-2} / \text{Hz}^{1/2}$ from 15 Hz to 20 kHz < 0.005 $\text{ms}^{-2}$ at 1 Hz
	Output impedance	> 1 MOhm
	Insulation	> 10 <sup>9</sup> MOhm
Mechanical	Case material	Stainless steel VA 1.4305
	Environmental protection	IP 65 (w/ cable)
	Cable connection	TNC socket
	Shock limit	< 250 $\text{kms}^{-2}$
	Weight	40 g
	Installation height A (see below)	
	w/ coaxial cable & straight TNC plug	> 115 mm
	Mounting	M8 thread
EX	Marking, gas explosion protection	 II 2 G Ex ib IIC T4
	Marking, dust explosion protection	 II 2 D Ex ib IIIB T <sub>5</sub> 187°C

### Dimensions

in mm

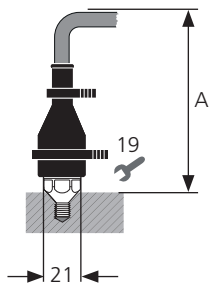

### Frequency response

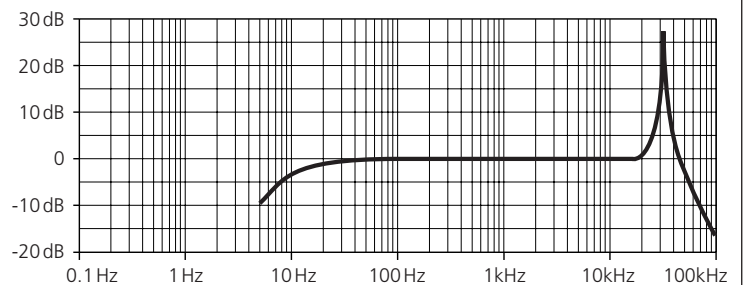

C

## Industrial accelerometers for low-speed machinery ( $n > 20 \text{ min}^{-1}$ ), intrinsically safe

1

VIB 6.107 DEX : Industrial accelerometer for low-speed machinery, adhesive mount, intrinsically safe

VIB 6.127 DEX : Industrial accelerometer for low-speed machinery, M8 thread mount, intrinsically safe

VIB 6.137 DEX : Industrial accelerometer for low-speed machinery, UNC 5/16 thread mount, intrinsically safe

2

3

4

5



Adhesive mount



Thread mount



6

### Application

These accelerometers are suitable for vibration measurements up to 10 kHz on low-speed machinery with rotational speeds above  $20 \text{ min}^{-1}$ . High frequency shock pulse measurements for bearing condition evaluation and pump cavitation are not possible with this series.

The accelerometers are mainly used for continuous machine condition monitoring in a hazardous industrial environment. The signal acquisition and processing is carried out with a condition monitoring system from PRÜFTECHNIK (e.g. VIBNODE, VIBROWEB,...).

The accelerometers are gas and dust explosion-proof. They are suitable for use with dusts having a minimum ignition temperature for 5 mm layers of not less than  $210 \text{ }^\circ\text{C}$ .

### Notes on intrinsic safety

The accelerometers of the series VIB 6.1xx DEX may only be connected to designated devices with the following interface parameters:

$$\begin{aligned} U_{\max} &= 24\text{V} \\ P_{\max} &= 300\text{mW} \\ C_i &= 15\text{nF} \\ L_i &= \text{negligible small} \end{aligned}$$

The following documents must be considered:

- EC type examination certificate TÜV 02 ATEX 1865
- 1st supplement dated from 01.03.2007
- 2nd supplement dated from 22.06.2011

Additionally the installation notes for hazardous areas annexed in this catalog must be observed.

### Installation accessories

Mounting tools for screw threads:

VIB 8.693	M8 screw tap
VIB 8.696	UNC 5/16 screw tap
VIB 8.694	90° countersink bit

Mounting adapters for M8 screw threads:

VIB 3.474	Screwed adapter to M16
VIB 3.475	Screwed adapter to M20
VIB 8.772	Screwed adapter to M10
VIB 3.411	-, w/ locking nut to M8
VIB 3.412	-, w/ locking nut to M10
VIB 3.413	-, w/ locking nut to M12
VIB 3.431	-, w/ adhesive mount

Mounting adapters for UNC 5/16 screw threads:

VIB 3.414	Screwed ad. w/ locking nut to UNC 5/16
VIB 3.415	-, w/ locking nut to UNC 3/8 - 16
VIB 3.416	-, w/ locking nut to UNC 1/2 - 13
VIB 3.432	-, w/ adhesive mount

Extension post for M8 screw threads:

VIB 8.586	length: 55 mm
VIB 8.587	length: 95 mm
VIB 8.588*	length: 170 mm
VIB 8.589	length: 35 mm

Extension post for UNC 5/16 screw threads:

VIB 8.590	length: 2 1/8"
VIB 8.591	length: 3 3/4"
VIB 8.592*	length: 6 5/8"

\* only for shock pulse measurements!

Installation material for adhesive mount:  
2-component adhesive (e.g. WEICON HB 300).



## Technical data

PARAMETER		VIB 6.107 DEX	VIB 6.127 DEX	VIB 6.137 DEX
Measurement	Signaling system	Current LineDrive, 3.5 mA closed current with superposed AC signal		
	Transmission factor $\pm 4\%$	5.35 $\mu\text{A}/\text{ms}^{-2}$ (Reference: 159 Hz; 25 °C)		
	Frequency range $\pm 5\%$	2 Hz ... 4 kHz		
	$\pm 10\%$	1 Hz ... 6 kHz		
	$\pm 3\text{dB}$	0.3 Hz ... 10 kHz		
	Resonance frequency	17 kHz; > 20 dB damped		
	Linearity range $\pm 10\%$	$\pm 450 \text{ ms}^{-2}$		
Electrical	Temperature range, w/ PVC cable	-30 °C ... +80 °C		
	Power requirement	> 10 mA / 7-18 VDC		
	Transverse sensitivity	< 5% at 10 kHz		
	Temperature sensitivity	< 0.01 $\text{ms}^{-2}/\text{K}$		
	Magnetic sensitivity	< 1 $\text{ms}^{-2}/\text{T}$ (bei 50 Hz)		
	Base strain sensitivity	< 0.1 $\text{ms}^{-2}/\mu\text{m}/\text{m}$		
	Electrical noise, rms	< 0.002 $\text{ms}^{-2}$ from 2 Hz		
	Output impedance	> 300 kOhm		
Mechanical	Insulation	> 10 <sup>9</sup> MOhm		
	Case material	Stainless steel VA 1.4305		
	Environmental protection	IP 65 (w/ cable)		
	Cable connection	TNC socket		
	Shock limit	< 50 $\text{kms}^{-2}$		
	Weight	41 g	43 g	
	Installation height A (see below)			
	w/ coaxial cable & straight TNC plug	> 124 mm	> 120 mm	
EX	Mounting	Adhesive	M8 thread	UNC 5/16 thread
	Marking, gas explosion protection	II 2 G Ex ib IIC T4		
Marking, dust explosion protection	II 2 D Ex ib IIIB T <sub>3</sub> 187°C			

### Dimensions

in mm

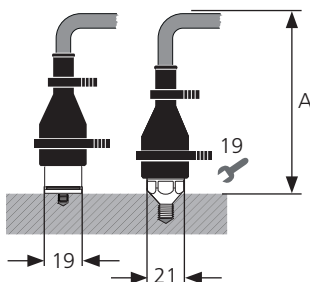

### Frequency response

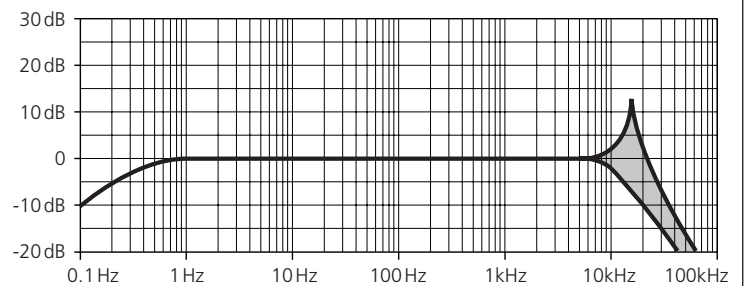

## C Mini accelerometers, intrinsically safe

1

VIB 6.202-6XD: Mini accelerometer with RG 174 cable, 6 meters, intrinsically safe

VIB 6.202-10XD: Mini accelerometer with RG 174 cable, 10 meters, intrinsically safe

VIB 6.203-3XD: Mini accelerometer with Spec 44 cable, 3 meters, intrinsically safe

VIB 6.203-6XD: Mini accelerometer with Spec 44 cable, 6 meters, intrinsically safe

2

3

4

5

6

A

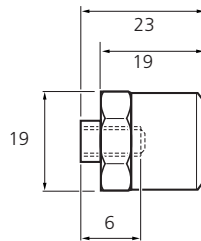
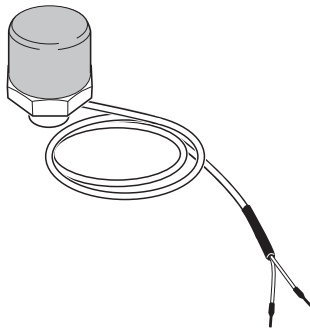

Dimensions in mm

size 19

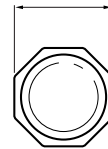

Vibration acceleration



Bearing condition



Pump cavitation



CE 0044

### Application

These accelerometers are suitable for vibration measurements up to 10 kHz on machinery with rotational speeds above 120 min<sup>-1</sup>, for shock pulse measurements on roller bearings and for cavitation measurements in pumps.

The compact design and the position of the cable, which is passed through the base, reduces the installation space required for this type of accelerometers considerably.

The accelerometers are mainly used for continuous machine condition monitoring in a hazardous industrial environment. The signal acquisition and processing is carried out with a condition monitoring system from PRÜFTECHNIK (e.g. VIBNODE, VIBROWEB,...).

### Installation accessories

- VIB 3.417-M5 M5 screwed adapter for mini accelerom.
- VIB 3.417-M6 M6 screwed adapter for mini accelerom.
- VIB 3.418 Adhesive adapter for mini accelerom.
- VIB 3.423 Magnetic holder for flat surfaces

Installation material for adhesive mount:

2-component adhesive (e.g. WEICON HB 300).

Installation material for sensor cable

VIB 93025 TNC plug for RG 174 cable

VIB 81015 Protective sleeve for RG 174 cable

### Mounting types

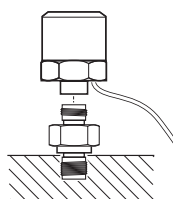

Screwed adapter  
VIB 3.417-M5  
VIB 3.417-M6

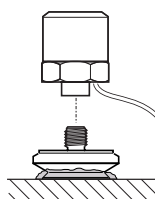

Adhesive adapter  
VIB 3.418

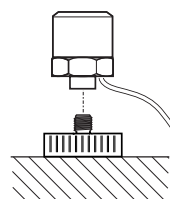

Magnetic adapter  
VIB 3.423

### Notes on intrinsic safety

Mini accelerometers of the series VIB 6.20..XD may only be connected to designated devices with the following interface parameters:

$$U_i = 24 \text{ V} \quad C_i = 15 \text{ nF}$$

$$P_i = 300 \text{ mW} \quad L_i = 0 \text{ H}$$

The sensor is delivered with a permanently attached cable. When selecting the cable length, take into consideration the capacitance and inductance of the cable type:

RG174	Spec 44
$C_{\text{cable}} = 111 \text{ pF}$	$C_{\text{cable}} = 430 \text{ pF}$
$L_{\text{cable}} = 277 \text{ nH}$	$L_{\text{cable}} = 154 \text{ nH}$

If the open cable ends are connected within the hazardous area, the explosion protection type must not be impaired, taking into account the intended use.

The sensor should be protected against mechanical destruction or damage.

The sensor should be protected from direct sunlight.

The intrinsically safe power circuit should be connected to the equipotential bonding system.

The details in the EC type examination certificate ZELM 07 ATEX 0327 X should be observed.

The admissible inductance and capacitance of the intrinsic power supply must be followed!

The European installation instructions (EN 60079-14 / EN 61241-14) must be followed.

The metal body isolated from the intrinsically safe supply must be electrostatically grounded.

Service and maintenance cannot be performed on the sensor.

## Technical data

PARAMETER		VIB 6.202.. XD	VIB 6.203.. XD
Measurement	Signaling system	Current Line Drive; $3.5 \pm 1.5$ mA closed current with superposed AC signal	
	Transmission factor $\pm 10\%$	$1.0 \mu\text{A}/\text{ms}^{-2}$ (Reference: 159 Hz; 25 °C)	
	Frequency range $\pm 10\%$	4 Hz ... 8 kHz	
	$\pm 3\text{dB}$	2 Hz ... 10 kHz	
	Resonance frequency	30 kHz	
	Linearity range $\pm 10\%$	$\pm 961 \text{ ms}^{-2}$ ( $\pm 98\text{g}$ )	
	Temperature range	-30 °C ... +80 °C	
Electrical	Power requirement	> 10 mA / 7-18 VDC	
	Temperature sensitivity	< $0.08 \text{ ms}^{-2}/\text{K}$	
	Electrical noise, rms	< $0.1 \text{ ms}^{-2}$ ab 2 Hz	
	Output impedance	> 250 kOhm	
Mechanical	Case material	Stainless steel VA 1.4305 / Grivory HTV (resistant amongst others to diesel, crude oil, hydraulic and engine oil, lubricants, tar, turpentine)	
	Environmental protection	IP 67 (w/ cable)	
	Shock limit	< $250 \text{ kms}^{-2}$	
	Weight	22 g	
	Dimensions	see figure below	
	Mounting	Adapter w/ UNF 1/4 thread	
	Connection cable	Coaxial, RG 174/U	Coaxial, Raychem Spec. 44
	Diameter	2.8 mm	2.4 mm
	Material	PVC - Polyvinylchloride	PVDF - Polyvinylidenfluoride: highly resistant to many acids, alkalis, hydrocarbon solvents, fuels, lubricants, water, and many missile fuels and oxidizers
Protective sleeve, material	EVA, non halogen line Temp.range: - 40°C .. +70°C	---	
EX	Marking, gas explosion protection	II 2 G Ex ib IIC T4	
	Marking, dust explosion protection	II 2 D Ex ibD 21 T95°C	

**Note**  
The maximum surface temperature for the installation in dust hazardous explosive areas (II 2 D) relates to procedure A of EN 61241-14 : 2005.

Frequency response - VIB 6.202 / VIB 6.203

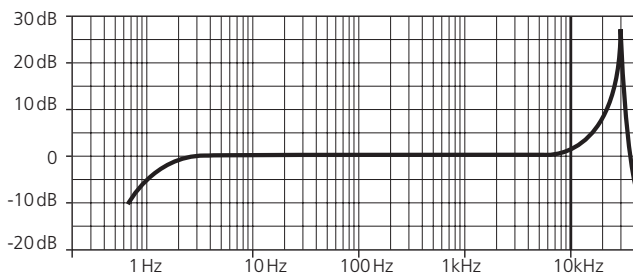

### Accessories for RG 174 cable



TNC plug  
VIB 93025



TNC plug + protective sleeve  
VIB 93025 + VIB 81015

C

## VIBROTECTOR vibration transmitters, intrinsically safe

1

VIB 5.731 EX : VIBROTECTOR vibration transmitter, 10 Hz - 1 kHz, intrinsically safe

VIB 5.736 EX : VIBROTECTOR vibration transmitter, 2 Hz - 1 kHz, intrinsically safe

2

3

4

5

6

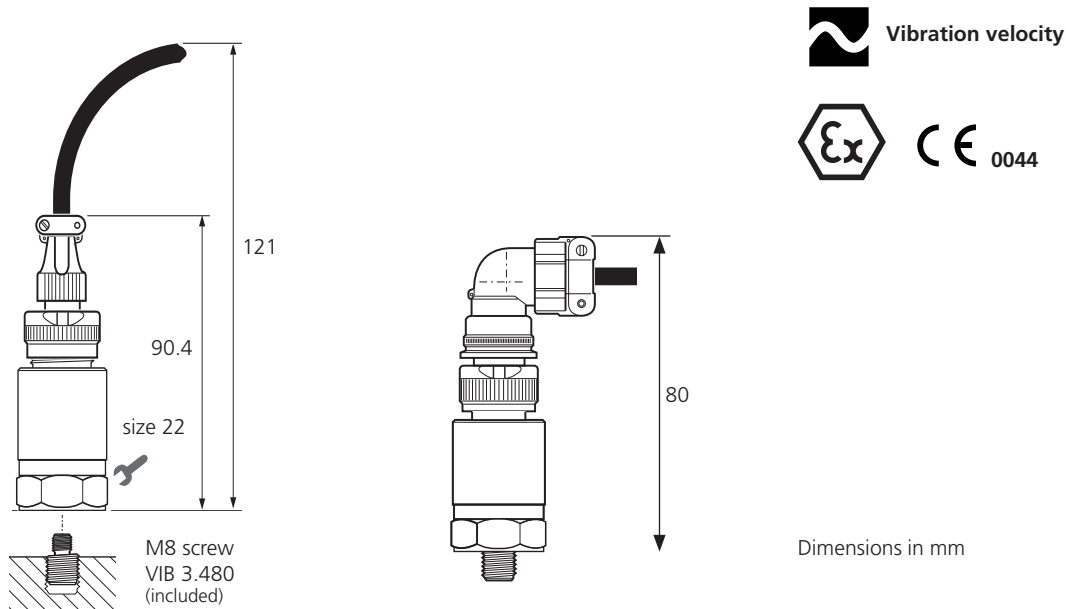

A

### Application

The VIBROTECTOR vibration transmitter measures vibration velocity and is used for the continuous monitoring of absolute machine vibrations. The output signal (4-20mA) is output for analysis and alarm directly on the control system.

### Installation accessories

Mounting tools for screw threads:

VIB 8.693 M8 screw tap

VIB 8.694 90° countersink bit

Mounting adapters for VIBROTECTOR:

VIB 3.437 Screwed adapter to M8-90°

VIB 3.438 Screwed adapter to M8 flat

VIB 3.439 Screwed adapter to M5 flat

VIB 3.480 M8 screw

VIB 3.433 Adhesive adapter

Installation material for adhesive mount:

2-component adhesive (e.g. WEICON HB 300).

Connection cables

VIB 3.570-6 Connection cable (PUR) w/ straight plug,  
VIB 3.570-12 6 or 12 meters long, permissible for a dust-  
and gas-explosive environment.

VIB 5.740-X Connection cable (silicone) w/ straight or  
VIB 5.741-X angled plug, X meters long, permissible  
for a dust-and gas-explosive environment.

0 2088 0010 Transmitter supply unit for VIBROTECTOR  
EX

### Mounting VIBROTECTOR

- Drill the mounting hole as shown in the graphics.
- Clean and smooth the area around the mounting hole (Abrasive paper, type 220).
- Clean both contact surfaces with solvent.
- Cover one of the dried surfaces with a thin film of LOCTITE 243 for better signal transmission.
- Screw in the VIBROTECTOR (3-7Nm!).

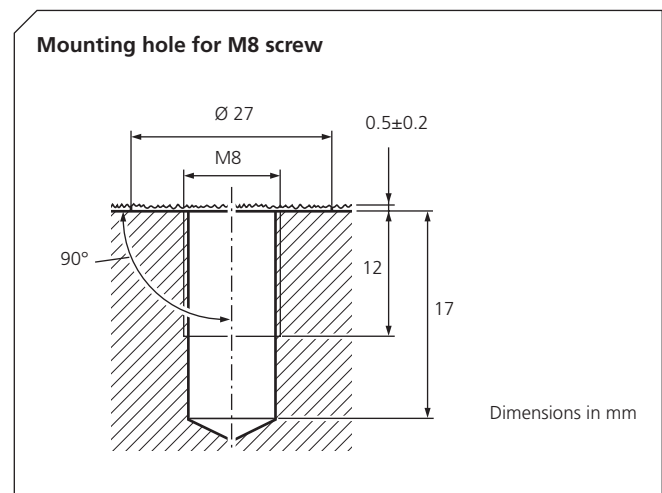

### Notes on intrinsic safety

VIBROTECTOR vibration transmitter of the series 5.731 EX and VIB 5.731 EX may only be connected to designated devices with the following interface parameters:

$$U_i = 30 \text{ V} \quad C_i = 15 \text{ nF}$$

$$P_i = 600 \text{ mW} \quad L_i = 0 \text{ H}$$

The details in the EC type examination certificate TÜV 05 ATEX 2788 should be observed.

The admissible inductance and capacitance of the intrinsic power supply must be followed!

The European installation instructions (EN 60079-14 / EN 61241-14) must be followed. Additionally the installation notes for hazardous areas annexed in this catalog must be observed.

The metal body isolated from the intrinsically safe supply must be electrostatically grounded.

Service and maintenance cannot be performed on the sensor.

### Technical data

PARAMETER		VIB 5.731 EX	VIB 5.736 EX
Measurement	Output signal	Current level (4-20mA)	
	Measurement range (RMS) ± 2%	≤ 20 mm/s (Ref.: 159 Hz)	
	Frequency range ± 10%	10 Hz ... 1 kHz	2 Hz ... 1 kHz
	Temperature range T <sub>A</sub>	-25 °C ... +80 °C	
	Temperature sensitivity	- 0.4 µA/K	
Electrical	Supply voltage (loop power)	24 VDC (±5%)	
	Loop resistance	90 ... 360 Ohm	
	Insulation	complete	
Mechanical	Case material	Stainless steel VA 1.4305	
	Environmental protection	IP 67 (IP 68 for dust explosion protection only w/ special cable, immersion depth: 10 m)	
	Shock limit	50 km/s <sup>2</sup>	
	Connector type	Cable connector, 2 pin (Cannon, Mil-C5015)	
	Weight	80 g	
	Mounting	M8 thread	
EX	Marking, gas explosion protection	Ex II 2 G EEx ib IIC T4	
	Marking, dust explosion protection	Ex II 2 D Ex ibD21 IP68 T90°C	

IP 67 (IP 68 bei Staub-Explosionsschutz nur mit Spezialkabel)  
Tauchtiefe (IP 68): 10 m

#### Sensor pin allocation

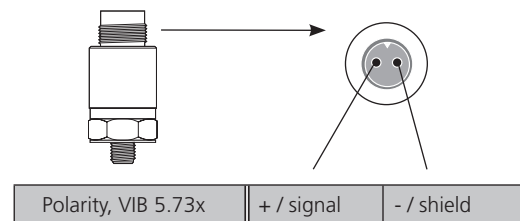

#### Note

The maximum surface temperature for the installation in dust hazardous explosive areas (II 2 D) relates to procedure A of EN 61241-14 : 2005.

### Frequency response

VIBROTECTOR, 10 Hz - 1 kHz (VIB 5.731)

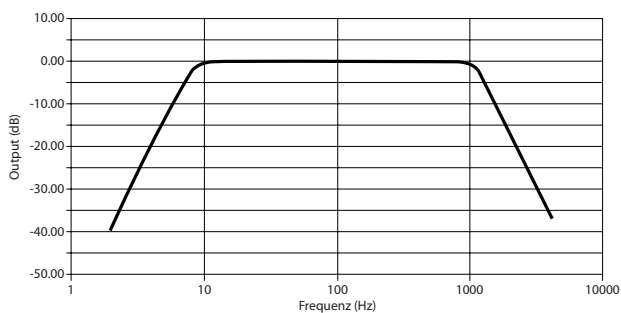

VIBROTECTOR, 2 Hz - 1 kHz (VIB 5.736)

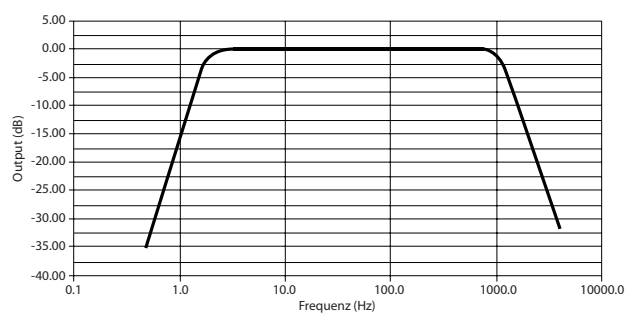

C

## VIB 6.172 XICP: ICP-type accelerometer for very low-speed machinery ( $n > 6 \text{ min}^{-1}$ ), intrinsically safe

1

2

3

4

5

6

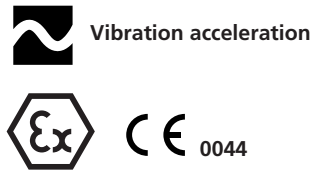
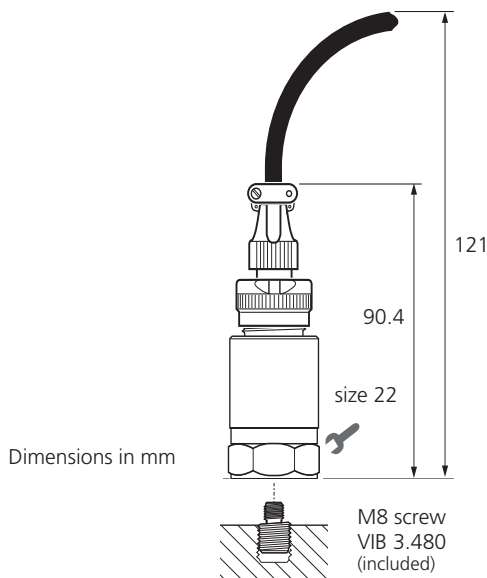

### Application

This accelerometer is used for the measurement of absolute machine vibrations. Due to the very low lower limit frequency, it is particularly suitable for very slowly rotating machinery components such as the main bearings of a wind turbine.

### Installation and connection

Permanent mounting using a threaded or adhesive adapter or a magnetic holder (see accessories list below).

### Installation accessories

Mounting tools for screw threads:

- VIB 8.693 M8 screw tap
- VIB 8.694 90° countersink bit

Mounting adapters for VIB 6.172:

- VIB 3.437 Screwed adapter to M8-90°
- VIB 3.438 Screwed adapter to M8 flat
- VIB 3.439 Screwed adapter to M5 flat
- VIB 3.480 M8 screw
- VIB 3.433 Adhesive adapter
- VIB 3.423 Magnetic holder for flat surfaces

Installation material for adhesive mount:

2-component adhesive (e.g. WEICON HB 300).

### Connection cables

- VIB 3.570-6 Connection cable (PUR) w/ straight plug, 6 meters long, permissible for a dust- and gas-explosive environment.
- VIB 3.570-12 Connection cable (PUR) w/ straight plug, 12 meters long, permissible for a dust- and gas-explosive environment.
- VIB 5.422 VIBXPERT connection cable for ICP-type accelerometers (only in gas-explosive environment)
- 0 2088 0009 Single-channel safety barrier for ICP-type accelerometers

### Mounting

- Drill the mounting hole as shown in the graphics.
- Clean and smooth the area around the mounting hole (Abrasive paper, type 220).
- Clean both contact surfaces with solvent.
- Cover one of the dried surfaces with a thin film of LOCTITE 243 for better signal transmission.
- Screw in the accelerometer (3-7Nm!).

### Mounting hole for M8 screw

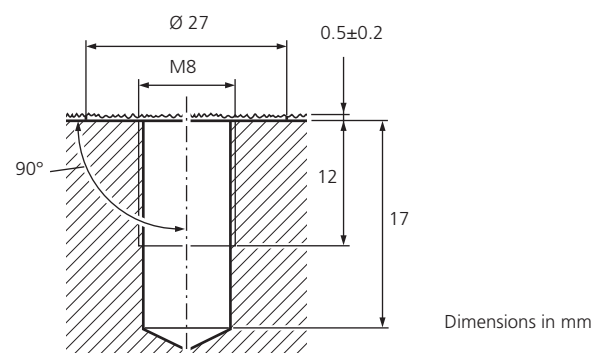

### Notes on intrinsic safety

The ICP-type accelerometer of the series VIB 6.172 XICP may only be connected to designated devices with the following interface parameters:

$$U_i = 38 \text{ V} \quad C_i = 10 \text{ nF}$$

$$P_i = 1 \text{ W} \quad L_i = 0 \text{ H}$$

The VIB 6.172 XICP accelerometer may be operated with VIBXPART EX in gas-explosive environment. The accelerometer is connected to the instrument with the VIBXPART cable for ICP-type accelerometers (VIB 5.422).

The operation with VIBXPART EX in dust hazardous areas is prohibited.

The details in the EC type examination certificate TÜV 05 ATEX 2795 should be observed.

The admissible inductance and capacitance of the intrinsic power supply must be followed!

The european installation instructions (EN 60079-14 / EN 61241-14) must be followed. Additionally the installation notes for hazardous areas annexed in this catalog must be observed.

The metal body isolated from the intrinsically safe supply must be electrostatically grounded.

Service and maintenance cannot be performed on the sensor.

### Technical data

PARAMETER		VIB 6.172 XICP
Measurement	Signaling system	ICP
	Transmission factor ± 4%	100 mV/g (Ref.: 159 Hz; 25 °C)
	Frequency range ± 3dB	0.1 Hz ... 10 kHz
	Resonance frequency	17 kHz; > 10 dB damped
	Linearity range ± 1%	< 70 g (r.m.s.)
	Temperature range	-40 °C ... +80 °C
Electrical	Power requirement	2 - 10 mA / 24 VDC (±10%)
	Bias, DC output	12 V DC (±0.5V)
	Grounding	insulated from machine ground, internal shielding
	Transverse sensitivity	< 5% at 5 kHz
	Temperature sensitivity	< 0.15 g/K
	Magnetic sensitivity	< 0.1 g/T (at 50 Hz)
	Base strain sensitivity	< 0.001 g/μm/m
	Acoustic sensitivity (130 dB)	0.0004 g
	Electrical noise, (0.1 Hz - 20 kHz)	< 0.0005 g
	Output impedance	< 10 Ohm
Mechanical	Case material	Stainless steel VA 1.4305
	Environmental protection	IP 67 (IP 68 for dust explosion protection only w/ special cable, immersion depth: 10 m)
	max. Shock limit	5000 g
	Connector type	Cable connector, 2 pole (Mil-C5015)
	Weight	85 g
	Dimensions	see previous page
EX	Marking, gas explosion protection	⊕ II 2 G Ex ib IIC T4
	Marking, dust explosion protection	⊕ II 2 D Ex ibD21 IP68 T95°C

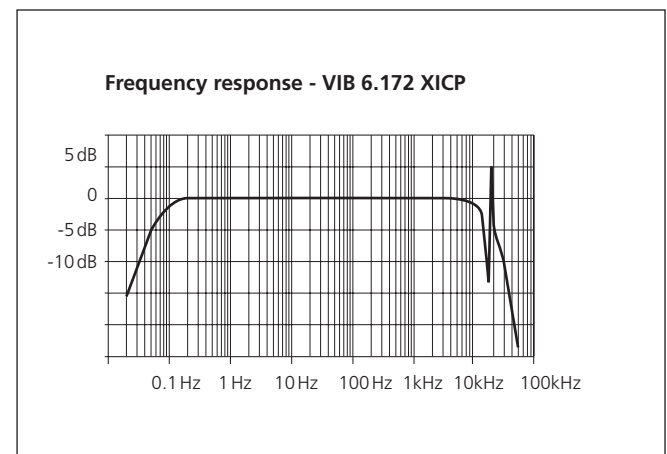

### Sensor pin allocation

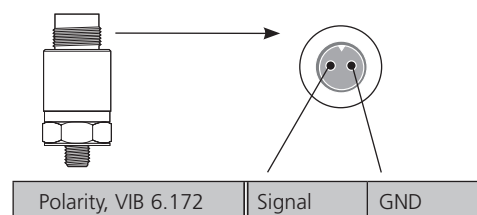

### Note

The maximum surface temperature for the installation in dust hazardous explosive areas (II 2 D) relates to procedure A of EN 61241-14 : 2005.

C

## VIB 5.991-DIS: Inductive displacement sensor

1

2

3

4

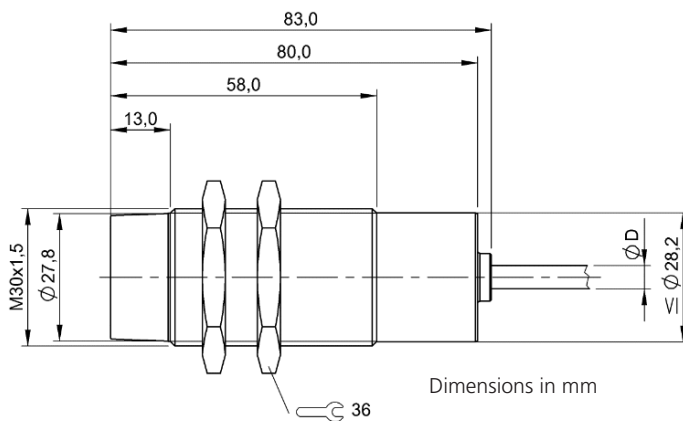

Displacement

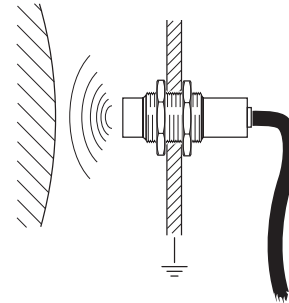

5

### Application

The displacement sensor is used for contact-free measuring the relative displacement and relative expansion.

6

### Note

The sensor is supplied with a connection cable (6 m).

### Function

The evaluation electronics are integrated in the sensor and provide an interference insensitive output signal that can also be transmitted over long distances.

A

### Technical data

PARAMETER		VIB 5.991-DIS
Measurement	Measuring principle	inductive
	Measurement variable	relative displacement / expansion
	Working range $S_a$	3 ... 15 mm
	Output current at $S_a = 0\text{mm} / \text{max.}$	1.5 / 10 mA
	Linearity range $S_i$	4.5 ... 12 mm
	Output current at $S_i = \text{min} / \text{max.}$	2.2 / 9.1 mA
	Switching function	Current falling on approach
	Switching output	PNP / Analog
	Repeat accuracy	$\pm 0.02\text{ mm}$
	Temperature range	$-10\text{ }^\circ\text{C} \dots +60\text{ }^\circ\text{C}$
Electrical	Operating voltage	10 - 30 V DC
	Rated operating voltage $U_e$	24 V DC
	Power / Adjustment indicator	no / no
	Short circuit / Polarity reversal prot.	yes / yes
	No-load current max. $I_o$ at $U_e$	10 mA
Mechanical	Housing material	Messing, vernickelt
	Sensing surface material	PA 12
	Environmental protection	IP 67
	Cable diameter $D$ max.	4.6 mm
	Einbaubedingung	non-flush
	Tightening torque	70 Nm
Size	M30	

### Characteristic

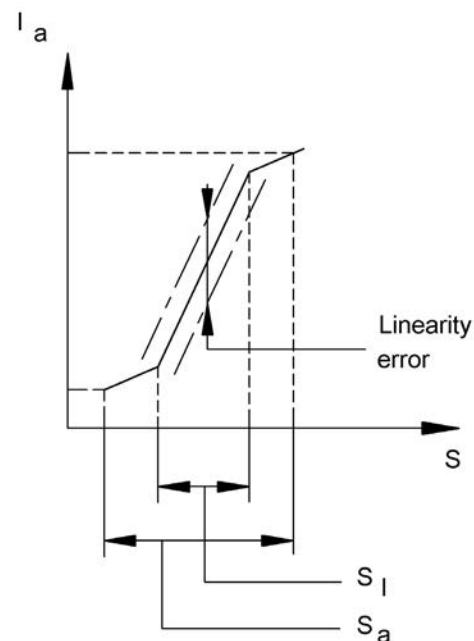

### Connection diagram





## VIB 5.992-NX: Inductive RPM sensor for wind power plants incl. cable

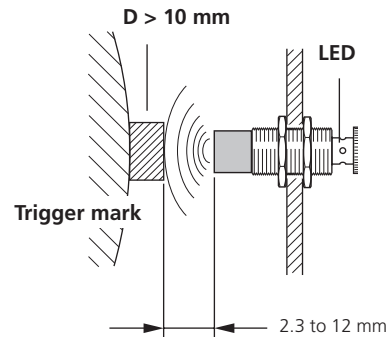
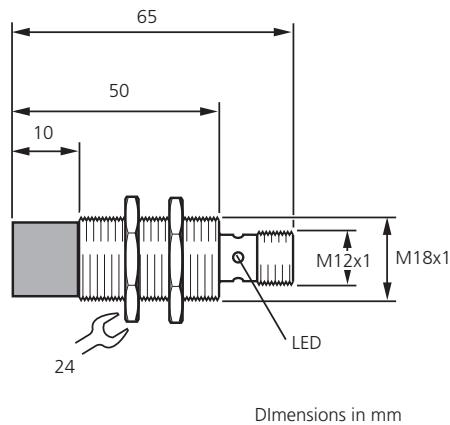

### Application

The inductive RPM sensor is used in online condition monitoring systems for wind power plants (e.g. VIBROWEB

XP) as a trigger sensor and for the measurement of machine RPM.

### Technical data

PARAMETER	VIB 5.992-NX	
Measurement	Measuring principle	Inductive
	Rated operating distance $S_n$	12 mm
	Assured operating distance $S_a$	0 ... 9.7 mm
	Repeat accuracy	5%
	Switching frequency	2500 Hz
	Switching function	Closer (NO)
	Operation display	yes
	Short-circuit protection	yes
	Reverse-connect protection	yes
	Magnetic field immune	immune to magnetic DC and AC fields
	Temperature range	-25 °C ... +70 °C
	Electrical	Operating voltage
Rated operating voltage $U_e$		24 V DC
Effective operating current $I_e$		200 mA
Voltage drop		< 2.5 V
Off-state current		< 0.08 mA
Mechanical	Housing material	CuZn, PTFE plated
	Sensing surface material	LCP + PTFE
	Environmental protection	IP 67
	Dimensions	M18 x 1 x 65 mm (DxH)
	Tightening torque	12 Nm
Mounting	non flush	

PARAMETER	Connection cable	
Cable design	Number of pins	3
	Cable length	15 m
	Cable diameter D	4.3 mm ± 0.20 mm
	Head 1 - Head 2 size	M12x1
	Coupling nut material	Zinc die cast (GD-Zn)
	Cable jacket material	PUR
General	Temperature range	-25 °C ... +80 °C
	Environmental protection	IP 68
	Additional features	Drag chain compatible

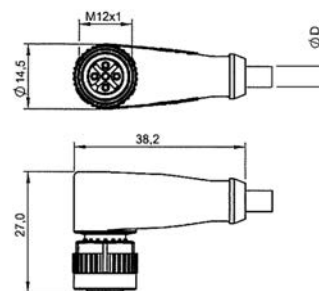

### Wiring and Pinout (cable)

#### Connection diagram and plug pin allocation (sensor)

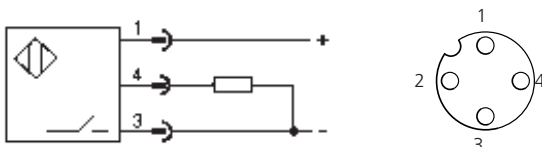



## VIB 5.992-STD: Default RPM sensor for Online CMS, incl. cable

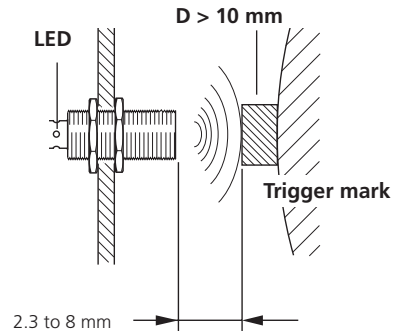
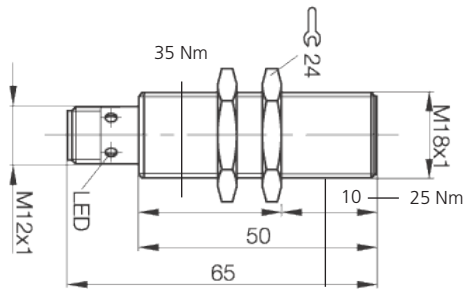

Dimensions in mm

### Application

The inductive RPM sensor is used in VIBGUARD, VIBNODE and VIBROWEB online condition monitoring systems as a trigger sensor and for the measurement of machine RPM.

### Technical data



PARAMETER		VIB 5.992-STD
Measurement	Measuring principle	Inductive
	Eff. switching distance $S_f$	8 mm
	Assured operating distance $S_a$	0 ... 6.4 mm
	Repeat accuracy (% of $S_f$ )	5%
	Switching frequency	1000 Hz
	Switching function	Closer (NO)
	Operation display	yes
	Short-circuit protection	yes
	Reverse-connect protection	yes
	Temperature range	-25 °C ... +70 °C
Electrical	Operating voltage	10 ... 30 V DC
	Rated operating voltage $U_e$	24 V DC
	Effective operating current $I_e$	200 mA
	Voltage drop	< 2.5 V
	Off-state current	< 0.01 mA
Mechanical	Housing material	CuZn, Nickel-free coating
	Sensing surface material	PBT
	Environmental protection	IP 67
	Dimensions	M18 x 1 x 65 mm (DxH)
	Tightening torque	25 / 35 Nm
Mounting	flush	

PARAMETER		Connection cable
Cable design	Number of pins	3
	Cable length	15 m
	Cable diameter D	4.3 mm ± 0.20 mm
	Head 1 - Head 2 size	M12x1
	Coupling nut material	Zinc die cast (GD-Zn)
	Cable jacket material	PUR
General	Temperature range	-25 °C ... +80 °C
	Environmental protection	IP 68
	Additional features	Drag chain compatible

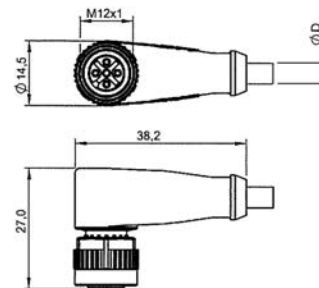

### Wiring and Pinout (cable)

#### Connection diagram and plug pin allocation (sensor)

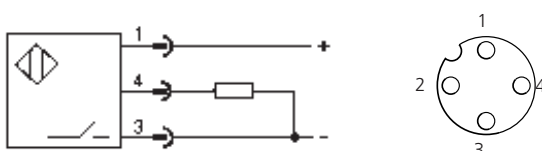

## VIB 6.610: Temperature probe PT100 for permanent mounting

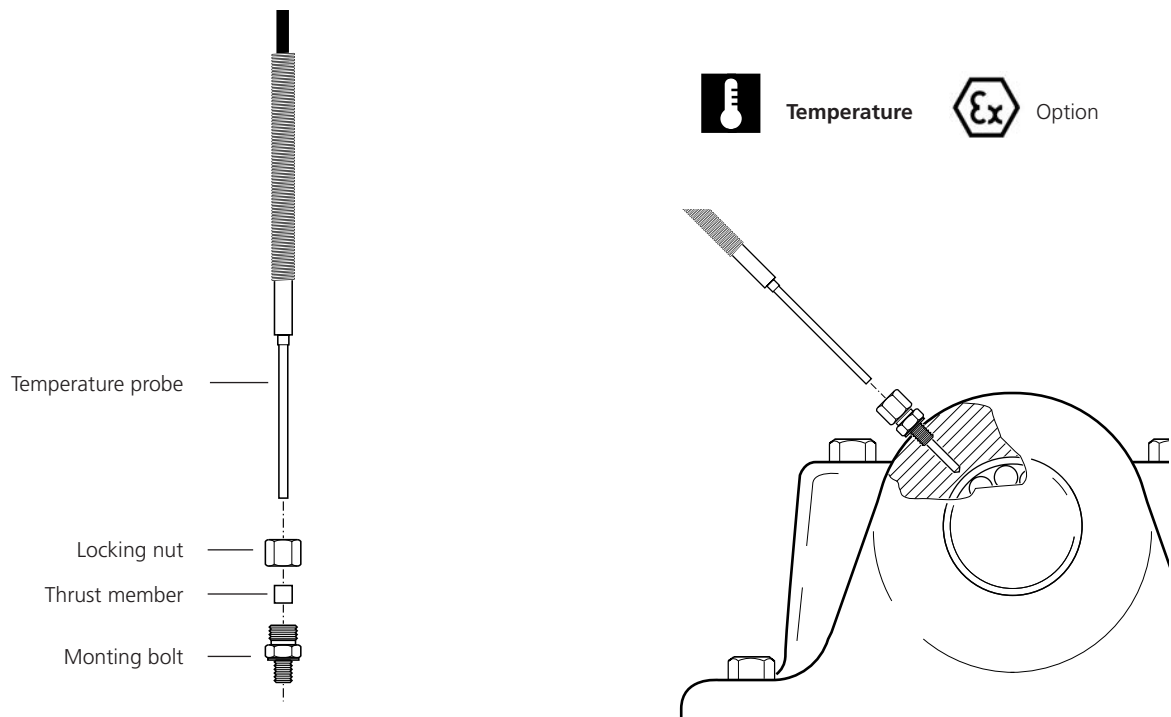

### Application

The temperature sensor PT 100 is used for temperature monitoring with an online condition monitoring system.

The sensor is mounted through the machine housing with a pressure-proof threaded fitting.

### Notes on the intrinsically safe version

The PT100 temperature sensor type RL-70-40 EX of the Rössel Messtechnik GmbH company is cast in plastic and tested with 500V against earth in compliance with the manufacturer declaration. Its self heating of 32 mW at 18 mA is negligible.

### Technical data

PARAMETER		VIB 6.610
Meas.	Sensor type	Pt 100 resistance thermometer
	Measurement range	0 ... +200 °C
	Limit deviation	DIN IEC 751 Kl. B
Mechanical	Material of the protective sheath	Rust- and acid-resistant steel
	Environmental protection, connector	IP 54
	Connection	Coaxial cable, 5 m long
	Dimensions	see figure

### Dimensions in mm

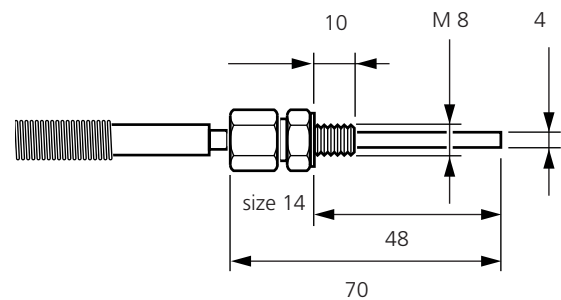

C

# Inductive RPM sensor for VIBRONET Signalmaster (f < 300 Hz)

1

- VIB 6.620 SET : Inductive RPM sensor for VIBRONET Signalmaster incl. connector; (f < 300 Hz)
- VIB 6.620 : Inductive RPM sensor for VIBRONET Signalmaster w/o connector; (f < 300 Hz)
- VIB 6.621 : Connector for sensor VIB 6.620

2

3

4

5

6

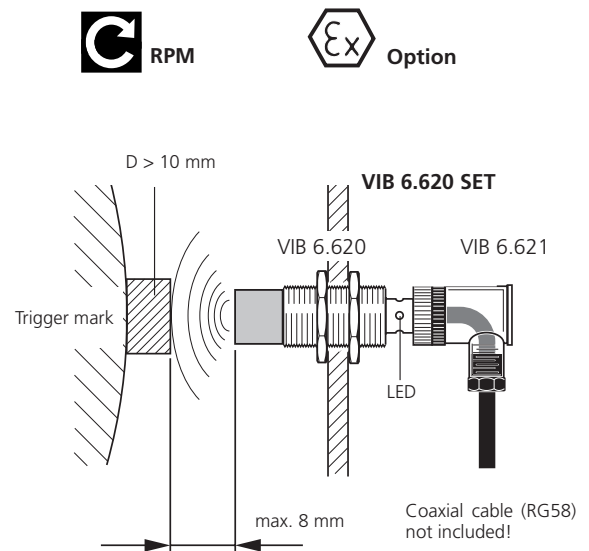
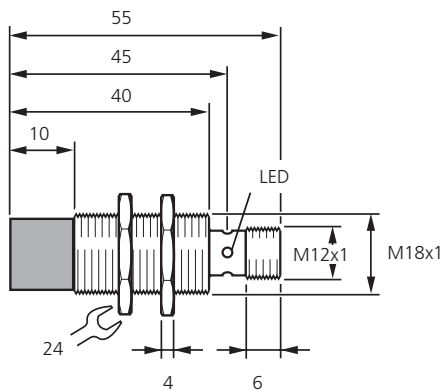

A

### Application

The sensor is used for inductive RPM measurements with the VIBRONET Signalmaster online condition monitoring system.

### Connection

The sensor is connected to the VIBRONET field multiplexer with the RPM connector module VIB 8.313.

### Technical data

PARAMETER		VIB 6.620
Measurement	Measuring principle	Inductive
	Rated operating distance $S_n$	8 mm
	Assured operating distance $S_a$	0 ... 6.48 mm
	Sensor type	NAMUR / opener
	Reduction factor $r(V2A) / r(Al) / r(Cu)$	0.72 / 0.42 / 0.4
	Switching frequency	0 ... 300 Hz
	Hysteresis H	1 ... 15 typ. 15%
	Operation display	LED, yellow
	Temperature range	-25 °C ... +100 °C
Electrical	Supply voltage	8 V DC (from RPM module)
	Current drain, meas. plate detected	≤ 1 mA
	-, meas. plate not detected	≥ 3 mA
	Short-circuit protection	yes
Mechanical	Reverse-connect protection	yes
	Installation	Non-flush
	Connection	V1 instrument connector
	Case material	Stainless steel
	Face material	PBT
	Environmental protection	IP 67
	Dimensions	see figure
EX	Operation in hazardous area	see operating instructions
	Marking	Ⓒ II 2 G EEx ia IIC T6

### Cable connection, sensor side

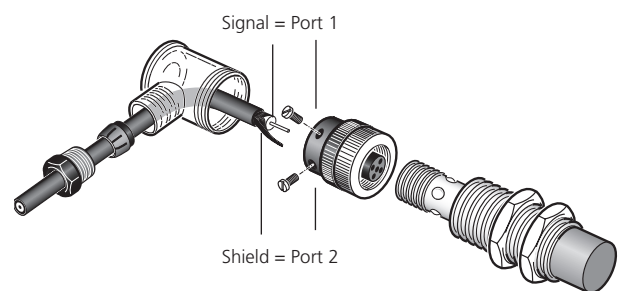

### Connection diagram

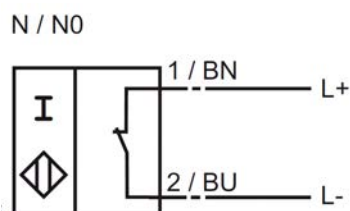

## Inductive RPM sensor for VIBRONET Signalmaster ( $f < 1500$ Hz)

VIB 6.622 SET : Inductive RPM sensor for VIBRONET Signalmaster incl. connector; ( $f < 1500$  Hz)

VIB 6.622 : Inductive RPM sensor for VIBRONET Signalmaster w/o connector; ( $f < 1500$  Hz)

VIB 6.621 : Connector for sensor VIB 6.622

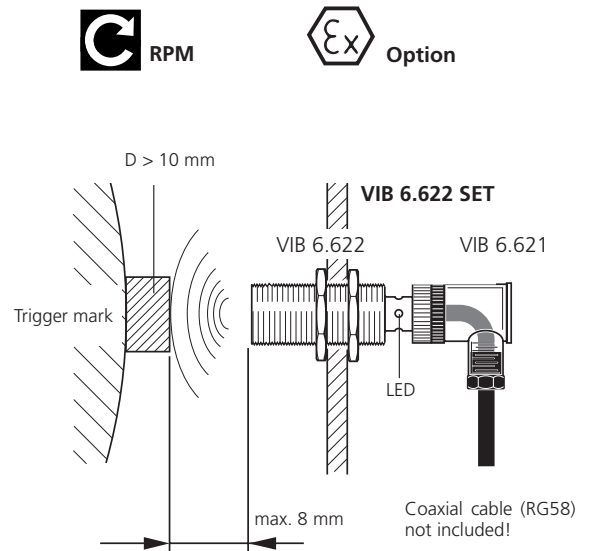
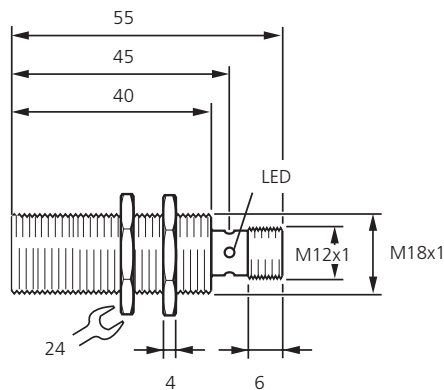

### Application

The sensor is used for inductive RPM measurements with the VIBRONET Signalmaster online condition monitoring system.

### Connection

The sensor is connected to the VIBRONET field multiplexer with the RPM connector module VIB 8.313.

### Technical data

PARAMETER		VIB 6.622
Measurement	Measuring principle	Inductive
	Rated operating distance $S_n$	8 mm
	Assured operating distance $S_a$	0 ... 6.48 mm
	Sensor type	NAMUR / opener
	Reduction factor $r(V2A) / r(Al) / r(Cu)$	0.71 / 0.39 / 0.36
	Switching frequency	0 ... 1500 Hz
	Hysteresis H	1 ... 15 typ. 15%
	Operation display	LED, yellow
	Temperature range	-25 °C ... +100 °C
Electrical	Supply voltage	8.2 V DC (from RPM module)
	Current drain, meas. plate detected	$\leq 1$ mA
	-, meas. plate not detected	$\geq 2.2$ mA
	Short-circuit protection	yes
Mechanical	Reverse-connect protection	yes
	Installation	flush
	Connection	M12 connector, 4 wire
	Case material	Stainless steel
	Face material	PBT
	Environmental protection	IP 67
	Dimensions	see figure
EX	Operation in hazardous area	see operating instructions
	Marking	Ⓜ II 1 G Ex ia IIC T6 Ga

### Cable connection, sensor side

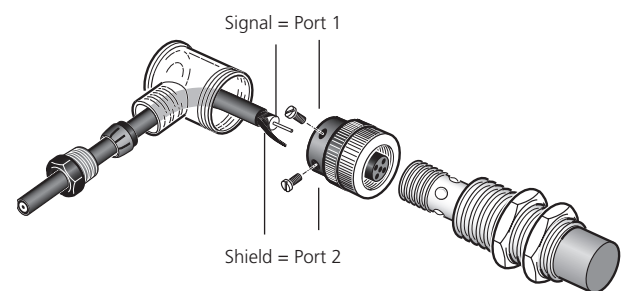

### Connection diagram

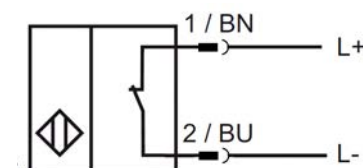



## VIB 6.641: Proximity sensor for Online CMS incl. cable (3-15 mm)

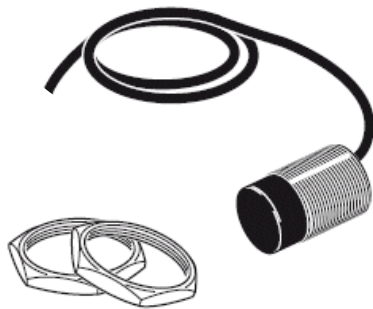

Displacement

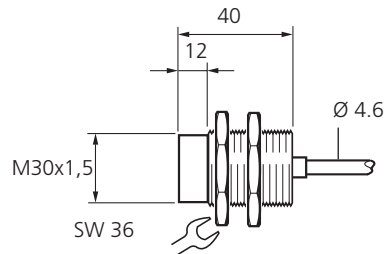

Dimensions in mm



### Application

The proximity sensor is used for contact-free measuring the gap of metallic objects within the specified range (3 - 15 mm).



### Function

The sensor is suitable for measurements without the highest precision requirements. The linearization of the char-

acteristic curve is automatically done in the online condition monitoring system.

### Mounting

The through tapped hole enables the simple mounting and positioning of the sensor. The following notes according to EN 60947-5-2 for non-flush mounting in metal must be observed:

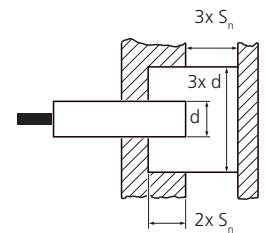

### Technical data

PARAMETER		VIB 6.641
Measurement	Measuring principle	Inductive
	Measurement variable	relative displacement / expansion
	Working range $S_n$	3 ... 15 mm
	Linearity	$\leq 5\%$
	Repeatability	$\leq 1\%$
	Average rise	0.333 V/mm $\pm 5\%$
	Max. frequency	300 Hz
	Influence $U_b$ on $U_a$ $dU_a/dU_b$	approx. 6.7% / 0.1V
	Temperature range	-25 °C ... +70 °C
Temperature drift	$\pm 5\%$	
Electrical	Operating voltage $U_b$	5 VDC, stabilized
	Operating current	$\leq 15\text{mA}$
	Output signal $U_a$	0.5 .. 4.5 VDC (see characteristic)
	Load resistance	$\geq 20\text{ k}\Omega$
Mechanical	Case material	Nickel-plated brass
	Material of active surface	PCP
	Environmental protection	IP 67
	Installation	Non-flush
	Connection	PVC cable, 6 meters long, open end, LIYY 3x0.34mm <sup>2</sup>

### Characteristic

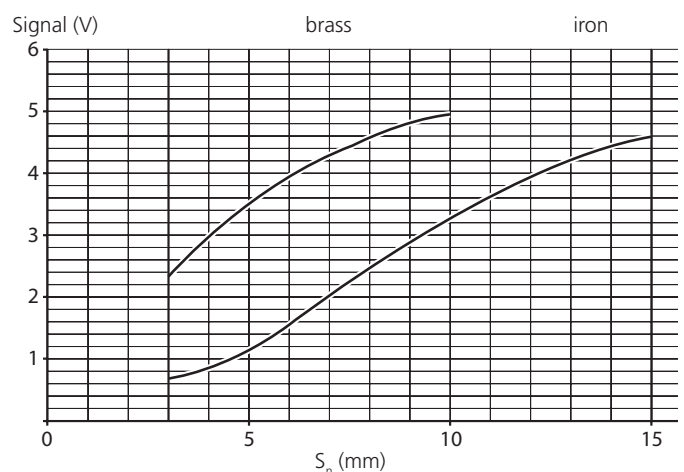

### Connection diagram



## VIB 6.645 SET: Displacement sensor for Online CMS incl. cable (2-10 mm)

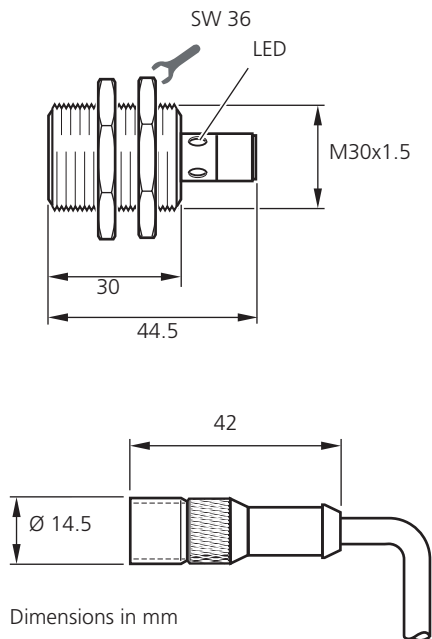

Displacement

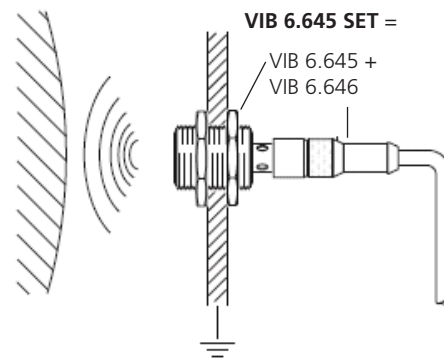

### Application

This displacement sensor can determine the position of metallic objects within the specified range (2 - 10 mm).

### Function

The displacement sensor is an inductive sensor that delivers a linear voltage output signal over the entire working range that is proportional to the distance from the measured object.

### Mounting

The through tapped hole enables the simple mounting and positioning of the sensor. The minimum distance to the non-measured metal surface is  $3 \times s_e$ .

### Accessories

VIB 6.646 Connection cable w/ plug

### Technical data

PARAMETER	VIB 6.645 SET	
Measurement	Measuring principle	Inductive
	Measurement variable	relative displacement / expansion
	Linearity range $S_l$	2 ... 10 mm
	Rated operating distance $S_e$	6 mm
	Max. non-linearity at $S_e$	$\pm 3\%$ from $U_a$ max.
	Repeat accuracy	$\pm 10 \mu\text{m}$
	Max. frequency	500 Hz
	Adjusting indication	yes, LED
	Temperature range	$-10 \text{ }^\circ\text{C} \dots +70 \text{ }^\circ\text{C}$
	Temperature drift	$< 5\%$ from $U_a$ max.

PARAMETER	VIB 6.645 SET	
Electrical	Operating voltage $U_b$	24 VDC
	No-load supply current	$< 10 \text{ mA}$
	Output signal $U_a$	0 ... 10 VDC
	Output resistance	$> 2 \text{ k}\Omega$
Mechanical	Case material	Nickel-plated brass
	Material of active surface	PBT
	Environmental protection	IP 67
	Mounting in steel	flush
	Connection	PUR cable (10 m) + plug
Dimensions	see figure above	

### Connection diagram and plug pin allocation (sensor)

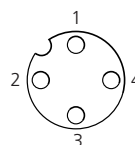

C

**VIB 5.993-MIC: Measuring microphone , CL 1 (DIN EN 60 651)**

1

2

3

4

BNC



5

**Application**

This microphone is used for noise emission measurement and analysis of disturbing noise. The microphone is designed with PRUFTECHNIK measurement devices for operational measurements.

6

**Design**

The microphone consists of a constant current powered measuring microphone preamplifier and an electret condenser microphone capsule.

A

**Calibration**

The measuring microphone can be calibrated with a sound pressure calibrator. Recommendations for appropriate calibrators are available on request.

**Accessories**

- VIB 6.632 Stand for laser trigger
- VIB 5.438-0,5 Connection cable for ICP-type accelerometer, 0.5 m
- VIB 344221-1 BNC cable, 1 m

**Connection**

The measuring microphone is connected to standard current powered measuring channels (IEPE standard / ICP).

For PRUFTECHNIK systems the following connection configurations are provided:

- VIBXPERT II: The measuring microphone is connected to the analog input channel using the ICP cable (VIB 5.438-0,5) and an appropriate BNC cable (i.e. VIB 344221-1), see below.
- VIBNODE, VIBROWEB XP, VIBGUARD: The measuring microphone is connected to an ICP-type terminal using an appropriate BNC cable.
- VIBRONET Signalmaster: The measuring microphone is connected to the connection module for ICP-type sensors (VIB 5.812-ICP).

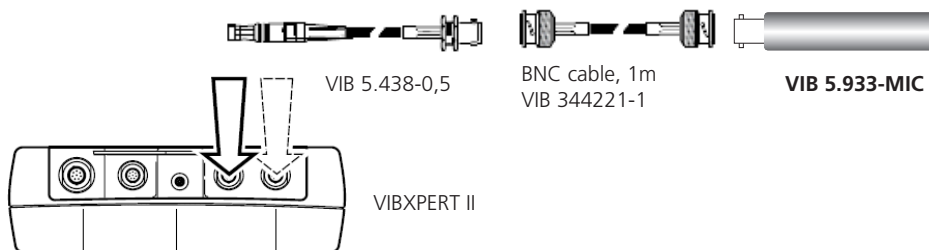
**Connection example**



## Technical data

PARAMETER		VIB 5.993-MIC
Messung	Transducer type	Capacitive pressure transducer
	Sensitivity *	50 mV/Pa
	Correction free-field for 1 kHz	0 dB
	Random incidence at 1 kHz	0 dB
	Principal axis	Microphone axis
	Frequency range free-field response *	3,5 Hz ... 20 kHz, CL 1 DIN EN 60 651
	Polarization voltage	0 V
	Capacitance at 1 kHz *	19 pF
	Max. SPL for THD $\leq$ 3% at 1 kHz	135 dB
	Output voltage, K=3%	$\geq 6.5 V_{\text{eff}}$
	Output impedance	$< 100 \text{ Ohm}$
	Nom. load impedance	100 kOhm
	Current consumption	2 ... 10 mA
	Transducer excitation	$U_L 24 \dots 30 \text{ VDC}$
	Time for power up	1 minute
	Equivalent loudness level	15 dB A
	Influence of magnetic field 80A/m, 50 Hz	$< 22 \text{ dB}$
Influence of vibration, 1m/s <sup>2</sup> , 20 Hz .. 1 kHz	60 dB	
Allgemein	Operating temperature range, $\pm 0.5 \text{ dB}$	$-20^\circ\text{C} \dots +65^\circ\text{C}$
	Main ambient temperature coefficient	$\leq 0.01 \text{ dB/K}$
	Main ambient pressure coefficient	$-1 \times 10^{-5} \text{ dB/Pa}$
	Influence of relative humidity, 30% to 90%	$< 0.1 \text{ dB}$
	Temperature limits	$-50^\circ\text{C} \dots +100^\circ\text{C}$
	Humidity limits	r.H $< 100\%$ ; absence of condensation
	Diameter	12.7 mm
	Length	97 mm
	Weight	45 g
	Plug	BNC

\* individually calibrated, see calibration certificate

## Polar patterns

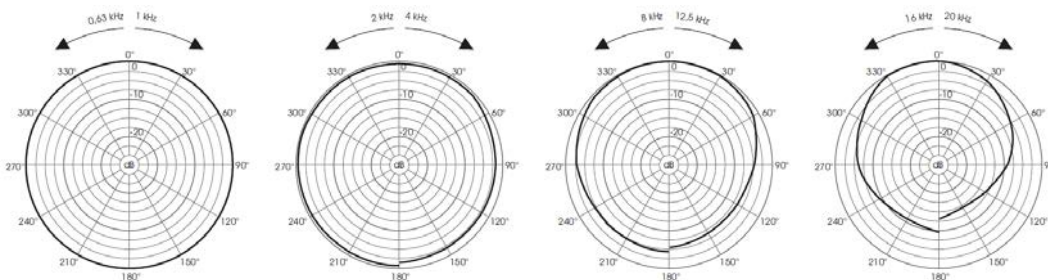

## Frequency response (calibration certificate)

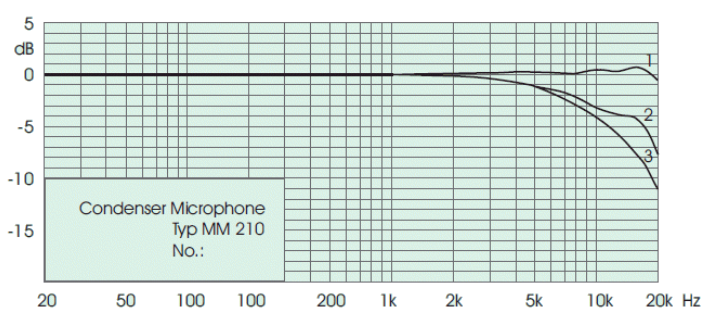

### Calibration Chart

Sensitivity S:  $-27.2 \text{ dB re } 1 \text{ V/Pa}$   
 equivalent to:  $43.6 \text{ mV/Pa}$   
 Cartridge Capacitance:  $15.0 \text{ pF}$

### Calibration Conditions

Polarization Voltage:  $0 \text{ V}$   
 Ambient Static Pressure:  $96.1 \text{ kPa}$   
 Ambient Temperature:  $23^\circ\text{C}$   
 Relative Humidity:  $67\%$

- 1 Zero Degree Incidence
- 2 Random Incidence
- 3 Actuator Pressure Response

Date: \_\_\_\_\_ Signature: \_\_\_\_\_

C

**VIB 6.411 SET: WEARSCANNER set with switching output**

1

2

3

4

5



VIB 6.411



VIB 9.840



VIB 6.421



VIB 6.425

6

**Application**

WEARSCANNER is used to detect, count and evaluate electrically conductive particles in lubricating oil circuits.

**Scope of delivery**

- VIB 6.411 WEARSCANNER particle counter w/ switching output
- VIB 6.421 M12 connector (for power supply and data line, 8 pins)
- VIB 6.425 M12 connector (for switching output, 5 pins)
- VIB 9.840.G Installation and operating instructions

**Accessories**

- VIB 6.420-L Connection cable for power supply and data transmission, assembled with M12 connector (VIB 6.421), L meters long (max. 20 m).
- VIB 6.426-L Connection cable for switching output, assembled with M12 connector (VIB 6.425), L meters long (max. 20 m).
- VIB 6.430 WEARSCANNER utility. Free software tool for commissioning and maintenance of the WEARSCANNER sensor can be downloaded from the PRÜFTECHNIK homepage.

**Description**

The WEARSCANNER is a sensor that detects electrically conductive particles in the medium that passes through it. The WEARSCANNER has the following features:

- Size-based counting and classification of particles
- Size classes are adjustable as specified in ISO 16232
- Continuous operation with integrated signal processing
- Suitable for lubricating oils
- Records oil temperature
- Temperature range: -20°C to +80 °C (+60°C, no flow)
- Large permissible flow rate range
- Many measurement functions customizable to machine and application, such as:
  - Threshold
  - Measurement time window
  - Electronic filter
  - Averaging
  - Gain etc.
- Internal ring memory for measurement data recording
- Persistent log file for the documentation of setting changes
- Modbus TCP communication
- Additional switching output as an option
- Network capability through its own IP address
- Switching output for signaling particle quantity exceeding
- Alive switching output for signaling system faults
- Self-monitoring
- Overload protection
- Maintenance-free

## Technical data

PARAMETER		VIB 6.411
Measurement	Measuring method	Eddy current, differential coil principle
	Particles	Ferritic or non-ferritic
	Particle size	Three size classes are set by default; up to 8 size classes can be set
	Signal processing	Particle distribution counter with integral average determination and classification
	Mean flow velocity	0.01 m/s ... 5 m/s
	Mean flow rate	0.08 l/min. ... 39 l/min.
	Oil types	Mineral, synthetic, biodegradable
	Oil pressure	Max. 16 bar operating pressure / 30 bar burst pressure
	Temperature range	Ambient: -20°C ... +80°C; -20°C ... +60°C (no flow) Oil: -20°C ... +80°C
Electrical	Power supply, Voltage	24 VDC (21 V ... 30 V)
	- , Current consumption	approx. 400 mA at 24 V
	- , Power consumption	approx. 9.6 W
	Switching capacity, switching output	24 VDC (max. 30 V) / 0.2 A (max., perm. load)
	- , alive output	24 VDC (max. 30 V) / 0.2 A (max., perm. load)
	Overload protection	Integrated
	Connector, Power supply / LAN	Male socket M12, 8 pins
	- , switching output / alive output	Male socket M12, 5 pins
	Permitted common-mode voltage	max. 50 V (housing / ground)
Data	Interface	Ethernet, 100 Mbit/s
	Protocols	TCP/IP, Modbus-TCP
	Internal memory	64 MB, sufficient for data-storage period from about 150 days to 10 years, depending on the data logger time interval
	Display	System signal LED 1: green = ready, rot = fault Operat. signal LED 2: Orange = particles passing through, Red = overload (particles too big/many, offset voltage too high)
	Self-monitoring	Integrated
Mechanical	Housing material	Stainless steel 1.4308 (salt water resistant)
	Fitting dimensions	2 x G 1/2" (Whitworth pipe thread DIN ISO 228)
	Sensor tube diameter	approx. 13 mm
	IP rating	IP 65
	Weight	approx. 3.5 kg
	Maintenance	No moving parts, maintenance-free
	Dimensions, WEARSCANNER	approx. 170 x 86 x 102 mm <sup>3</sup> (L x W x H)
Dimensions, mounting base (mounted upon delivery)	approx. 137 x 110 x 3 mm <sup>3</sup> (L x W x H)	

## Particle size classes

(ISO 16232)

— Size classes covered by the WEARSCANNER —

Klasse	B	C	D	E*	F*	G*	H	I	J	K
Größe	5 – 15 µm	15 – 25 µm	25 – 50 µm	50 – 100 µm	100 – 150 µm	150 – 200 µm	200 – 400 µm	400 – 600 µm	600 – 1000 µm	>1000 µm

\* Classes E, F, G only with appropriate configuration

C

## Online VIEW 4.0 - Visualization software for Online CMS

1

VIB 8.170: Online VIEW 4.0 for up to 100 data points

VIB 8.171: Online VIEW 4.0 for up to 250 data points

VIB 8.172: Online VIEW 4.0 for up to 500 data points

VIB 8.173: Online VIEW 4.0 for up to 1000 data points

2

3

4

5

6

A

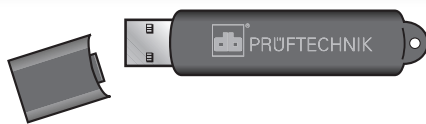
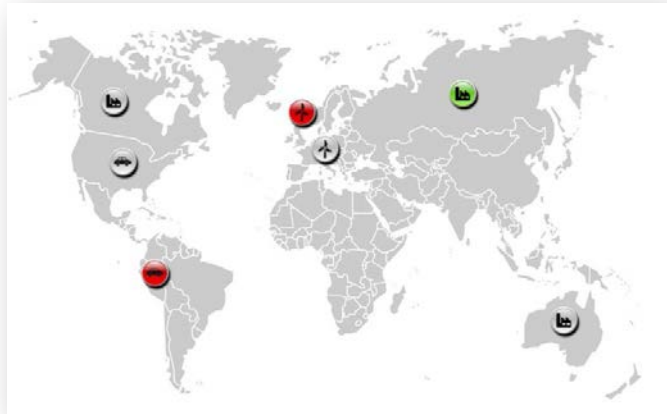

VIB 8.140-USB



### Application

This web-based software is used for online visualization of machine condition data that is collected with PRUFTECHNIK online CMS\* and provided via Modbus TCP. The data is displayed in real time on a PC or mobile devices.

Online VIEW 4.0 runs in a current browser, where the monitored assets, machines and the relevant status information are presented clearly and attractively.

Scope of supply:

VIB 8.140-USB Online VIEW 4.0 USB pendrive

### Note

The individual software packages are available based on the required data points. A data point corresponds to a Modbus address, i.e. a characteristic overall value, or an alarm, or a warning is one data point.

\* CMS: Condition Monitoring System

### Overview

- Client-Server application
- No additional client software required, web browser with Silverlight plug-in is sufficient.
- Visualization on mobile devices as an option
- Configuration and commissioning done by PRUFTECHNIK
- User interface in more than 150 languages
- Visualization of three levels (asset, machine train, machine) plus status overview
- Status overview with traffic light function
- Several display options for data visualization (bar chart, digital meters, analog instrument)
- Historical data and live data, each as a trend
- Compatible online CMS:
  - WEARSCANNER
  - VIBGUARD
  - VIBNODE
  - VIBROWEB
  - VIBROWEB XP
  - VIBCONNECT RF

## Chapter 2

# Sensors for mobile data collection



C

1

**2**

3

4

5

6

A

## Contents : Sensors for mobile data collection

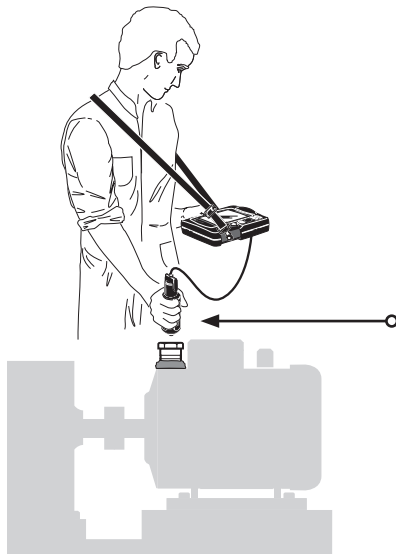

Order no.	Description	Page
VIB 6.142 R	Mobile industrial accelerometer for standard machinery	68
VIB 6.142 DEX	Mobile industrial accelerometer for standard machinery, intrinsically safe	70
VIB 6.147	Mobile industrial accelerometer for low-speed machinery	69
VIB 6.147 DEX	Mobile industrial accelerometer for low-speed machinery, intrinsically safe	72
VIB 6.162 VD VIB 6.162 VT	Dual sensor for vibration and temperature measurement with VIBSCANNER/ VIBXPART (VD) VIBTOOL (VT)	74
VIB 6.631	Laser trigger / Laser RPM sensor	84
VIB 6.631 EX	Laser trigger / Laser RPM sensor, intrinsically safe	86
VIB 6.640	Inductive proximity sensor for VIBXPART / VIBSCANNER	88
VIB 6.655	Triaxial accelerometer for VIBXPART	81
VIB 6.672	LED stroboscope	89
VIB 6.673	Current clamp	90
VIB 8.605	Built-in temperature probe for VIBROTIP / VIBSCANNER (spare part)	82
VIB 8.606 VD VIB 8.606 VS	TIPTECTOR handheld probe, -, set for VIBROTIP -, set for VIBSCANNER / VIBXPART	76
VIB 8.606 XVD VIB 8.606 XVS	TIPTECTOR handheld probe, intr. safe -, set for VIBROTIP EX -, set for VIBSCANNER EX	78
VIB 8.607-1,5 VIB 8.608	Temp. probe with magnetic holder Handheld temperature probe	82
VIB 8.609 VIB 8.633	TIPTECTOR grip extension, 100 mm TIPTECTOR grip	76
VIB 8.660 VS VIB 8.660 VD VIB 8.660 VIB 8.691	VIBCODE transducer incl. cable -, for VIBSCANNER and VIBXPART -, for VIBROTIP -, as replacement part w/o cable Dust cap for VIBCODE transducer	64
VIB 8.660 XVS VIB 8.660 XVD VIB 8.660 HEX	VIBCODE transducer incl. cable, int. safe -, for VIBSCANNER EX and VIBXPART EX -, for VIBROTIP EX and VIBTOOL -, as replacement part w/o cable	66
VIB 8.666 VD VIB 8.666 VS VIB 8.666 R	Mobile accelerometer with quick fitting coupling incl. cable -, for VIBROTIP -, for VIBSCANNER / VIBXPART -, as replacement part w/o cable	80

C

## VIBCODE transducer with automatic location identification

1

VIB 8.660 VS : VIBCODE transducer for VIBSCANNER and VIBXPERT

VIB 8.660 VD : VIBCODE transducer for VIBROTIP

2

Code ring sensor

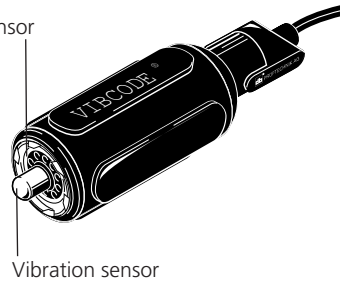

Vibration sensor



Vibration acceleration



Bearing condition



Pump cavitation

3

4

5

### Description

VIBCODE is the world's first vibration measurement system that uses coded measurement studs for certain identification of measurement locations on the machine. The system consists of the VIBCODE transducer and the VIBCODE measurement stud.

The VIBCODE transducer contains a code ring sensor and a vibration sensor. The transducer locks onto the VIBCODE stud via bayonet mount in optimum position and with consistent pressure. Trend readings are taken with perfect repeatability regardless of operator qualification and training. The code ring sensor reads the tooth pattern of the plastic ring in the measurement stud to determine its location so that the correct types of measurement can be taken. Mix-ups, erroneous trend deviations and time-consuming repeat measurements are all eliminated once and for all.

A

### Application

The signal acquisition and processing is carried out with a PRÜFTECHNIK data collector (e.g. VIBSCANNER, VIBXPERT II, VIBROTIP).

### Spare parts

VIB 8.660 VIBCODE transducer w/o cable

VIB 8.691 Dust cap for VIBCODE transducer

### Accessories

VIB 8.679 SET Meas. stud, M8, stainless steel

VIB 8.680 SET Meas. stud, M8, high qual. stainless steel

VIB 8.689 SET Meas. stud, UNC 5/16, hq. stainless steel

VIB 8.690 SET Meas. stud, UNC 5/16, stainless steel

VIB 8.571..73 Meas. studs w/ counter nut, M8

VIB 8.594..96 Meas. studs w/ counter nut, UNC 5/16

VIB 8.576..78 Meas. studs w/ extension post, M8

VIB 8.580..82 Meas. studs w/ extension post, UNC 5/16

VIB 8.685 Meas. stud for adhesive mounting

Installation material for adhesive mount:  
2-component adhesive (e.g. WEICON HB 300).

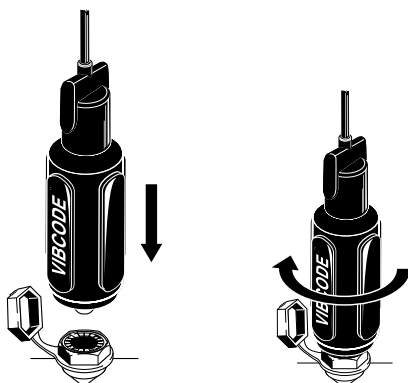



## Technical data

PARAMETER		VIB 8.660 VS	VIB 8.660 VD
Measurement	Signaling system	Current Line Drive; 3.5 mA closed current w/ superposed AC signal	
	Transmission factor ± 2%	1.0 $\mu\text{A}/\text{ms}^{-2}$ (Ref.: 159 Hz; 25 °C)	
	Frequency range ± 10%	2 Hz ... 10 kHz	
	± 3dB	1.5 Hz ... 20 kHz	
	Resonance frequency	36 kHz	
	Linearity range ± 10%	± 50 $\text{ms}^{-2}$ (±5g)	
	Temperature range	-10 °C ... +70 °C	
Electrical	Power requirements	> 10 mA / 7-18 VDC	
	Temperature sensitivity	< 0.3 $\text{ms}^{-2}/\text{K}$	
	Transverse sensitivity	< 10% of axial value	
	Magnetic sensitivity	< 14 $\text{ms}^{-2}/\text{T}$ (at 50 Hz)	
	Electrical noise, rms	< 1 $\text{mms}^{-2} / \text{Hz}^{1/2}$ at 10 Hz	
	Output impedance	> 500 kOhm	
Mechanical	Environmental protection	IP 65	
	Weight	390 g	
	Dimensions	136 mm x 39 mm (H x D)	
	Mounting	Adapters for VIBCODE transducer	
	Connection cable	VIB 5.436, VIB 5.437-2,9 / -5	VIB 4.704-2 / -5

### Frequency response

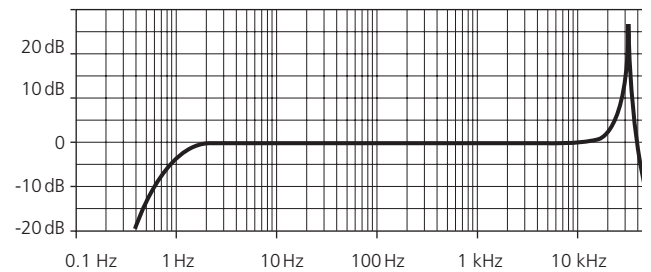

### Dimensions

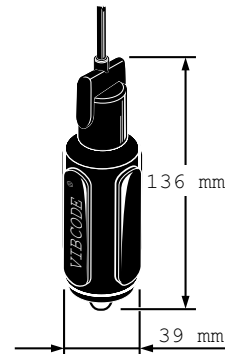

C

## VIBCODE transducer with automatic location identification, intrinsically safe

1

VIB 8.660 XVS : VIBCODE transducer with intrinsic safety for VIBSCANNER EX and VIBXPERT EX

VIB 8.660 XVD : VIBCODE transducer with intrinsic safety for VIBROTIP EX and VIBTOOL

2

3

4

5

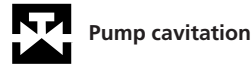
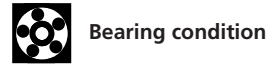
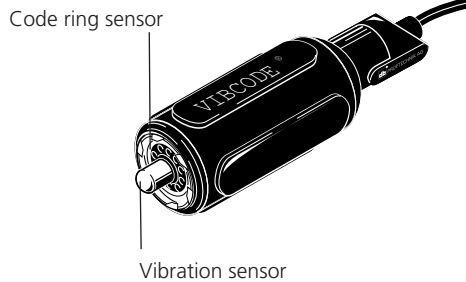

6

### Description

VIBCODE is the world's first vibration measurement system that uses coded measurement studs for certain identification of measurement locations on the machine. The system consists of the VIBCODE transducer and the VIBCODE measurement stud.

A

The VIBCODE transducer contains a code ring sensor and a vibration sensor. The transducer locks onto the VIBCODE stud via bayonet mount in optimum position and with consistent pressure. Trend readings are taken with perfect repeatability regardless of operator qualification and training. The code ring sensor reads the tooth pattern of the plastic ring in the measurement stud to determine its location so that the correct types of measurement can be taken. Mix-ups, erroneous trend deviations and time-consuming repeat measurements are all eliminated once and for all.

### Application

The intrinsically safe VIBCODE transducer is mainly used for data collection in a hazardous industrial environment. The signal acquisition and processing is carried out with an intrinsically safe PRÜFTECHNIK data collector (e.g. VIBSCANNER EX, VIBXPERT EX, VIBROTIP EX, VIBTOOL).

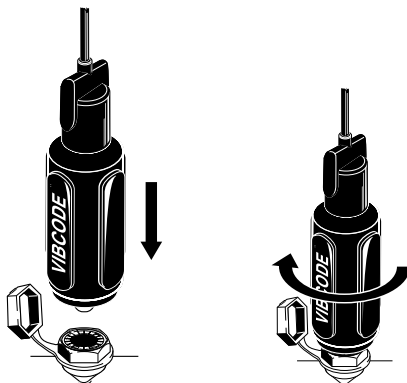

### Notes on intrinsic safety

The VIBCODE transducer of the series VIB 8.660 HEX may only be connected to designated devices with the following interface parameters:

$$\begin{aligned}
 U_{\max} &= 30 \text{ V} \\
 I_{\max} &= 63 \text{ mA} \\
 P_{\max} &= 300 \text{ mW} \\
 C_i &= 347 \text{ nF} \\
 L_i &= \text{negligible small}
 \end{aligned}$$

The details in the EC type examination certificate TÜV 02 ATEX 1890 and the 1st supplement dated from 31.10.2008 must be considered.

Additionally the installation notes for hazardous areas annexed in this catalog must be observed.

### Spare parts

VIB 8.660 HEX VIBCODE EX for VIBXPERT EX and VIBSCANNER EX w/o cable

VIB 8.691 Dust cap VIBCODE transducer

### Accessories

VIB 8.679 SET Meas. stud, M8, stainless steel  
 VIB 8.680 SET Meas. stud, M8, high qual. stainless steel  
 VIB 8.689 SET Meas. stud, UNC 5/16, hq. stainless steel  
 VIB 8.690 SET Meas. stud, UNC 5/16, stainless steel  
 VIB 8.571..73 Meas. studs w/ counter nut, M8  
 VIB 8.594..96 Meas. studs w/ counter nut, UNC 5/16  
 VIB 8.576..78 Meas. studs w/ extension post, M8  
 VIB 8.580..82 Meas. studs w/ extension post, UNC 5/16  
 VIB 8.685 Meas. stud for adhesive mounting

Installation material for adhesive mount:  
 2-component adhesive (e.g. WEICON HB 300).

## Technical data

PARAMETER		VIB 8.660 XVS	VIB 8.660 XVD
Measurement	Signaling system	Current Line Drive; 3.5 mA closed current w/ superposed AC signal	
	Transmission factor $\pm 2\%$	$1.0 \mu\text{A}/\text{ms}^{-2}$ (Ref.: 159 Hz; 25 °C)	
	Frequency range $\pm 10\%$	2 Hz ... 10 kHz	
	$\pm 3\text{dB}$	1.5 Hz ... 20 kHz	
	Resonance frequency	36 kHz	
	Linearity range $\pm 10\%$	$\pm 50 \text{ ms}^{-2}$ ( $\pm 5\text{g}$ )	
	Temperature range	-10 °C ... +70 °C	
Electrical	Power requirements	> 10 mA / 7-18 VDC	
	Temperature sensitivity	< $0.3 \text{ ms}^{-2}/\text{K}$	
	Transverse sensitivity	< 10% of axial value	
	Magnetic sensitivity	< $14 \text{ ms}^{-2}/\text{T}$ (at 50 Hz)	
	Electrical noise, rms	< $1 \text{ mms}^{-2} / \text{Hz}^{1/2}$ at 10 Hz	
	Output impedance	> 500 kOhm	
Mechanical	Environmental protection	IP 65	
	Weight	390 g	
	Dimensions	136 mm x 39 mm (H x D)	
	Mounting	Adapters for VIBCODE transducer	
	Connection cable	VIB 5.436, VIB 5.437-2,9 / -5	VIB 4.704-2 / -5
EX	Marking, explosion protect.	II 2 G Ex ib IIC T4	

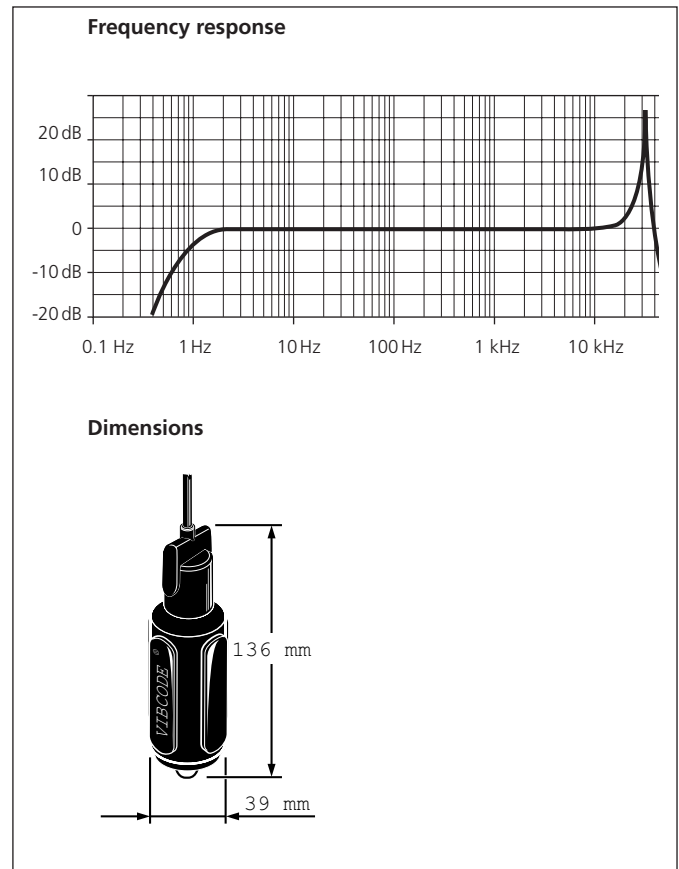

C

## VIB 6.142 R: Mobile industrial accelerometer for standard machinery ( $n > 600 \text{ min}^{-1}$ )

1

2

3

4

5

6

A



M5 thread



Vibration acceleration



Bearing condition



Pump cavitation

### Application

This accelerometer is suitable for vibration measurements up to 20 kHz on machinery with rotational speeds above  $600 \text{ min}^{-1}$ , for shock pulse measurements on roller bearings and for cavitation measurements in pumps.

The accelerometer is mainly used for data collection in an industrial environment. The signal acquisition and processing is carried out with a PRÜFTECHNIK data collector (e.g. VIBSCANNER, VIBXPERT II, VIBROTIP).

### Installation accessories

- VIB 3.420 Magnetic holder for curved surfaces
- VIB 3.422 Magnetic holder for flat surfaces
- VIB 3.430 Adapter for adhesive mounting
- VIB 3.435 Screwed adapter, M5-flat to M5-120°
- VIB 3.436 Screwed adapter, M5-flat to M6-90°
- VIB 3.440 Screwed adapter, M5-flat to M8-90°
- VIB 3.441 Screwed adapter, M5-flat to UNC5/16-90°
- VIB 3.450 Probe tip for accelerometer type VIB 6.14x

Installation material for adhesive mount:  
2-component adhesive (e.g. WEICON HB 300).

### Technical data

PARAMETER		VIB 6.142 R
Measurement	Signaling system	Current LineDrive, 3.5 mA closed current with superposed AC signal
	Transmission factor $\pm 3\%$	$1.0 \mu\text{A}/\text{ms}^{-2}$ (Ref.: 159 Hz; 25 °C)
	Frequency range $\pm 5\%$	2 Hz ... 8 kHz
	$\pm 10\%$	1 Hz ... 20 kHz
	$\pm 3\text{dB}$	0.3 Hz..20 kHz
	Resonance frequency	36 kHz
	Linearity range $\pm 10\%$	$\pm 961 \text{ ms}^{-2}$
	Temperature range	-30 °C ... +100 °C
Electrical	Power requirement	> 10 mA / 7-18 VDC
	Transverse sensitivity	< 5% at 10 kHz
	Temperature sensitivity	< $0.05 \text{ ms}^{-2}/\text{K}$
	Magnetic sensitivity	< $5 \text{ ms}^{-2}/\text{T}$ (at 50 Hz)
	Base strain sensitivity	< $0.1 \text{ ms}^{-2}/\mu\text{m}/\text{m}$
	Electrical noise, rms	< $0.01 \text{ ms}^{-2}$ from 2 Hz
	Output impedance	> 300 kOhm
Insulation	> $10^9 \text{ MOhm}$	
Mechanical	Case material	Stainless steel VA 1.4305
	Environmental protection	IP 65 (w/ cable)
	Cable connection	TNC socket
	Shock limit	< $250 \text{ kms}^{-2}$
	Weight	39 g
Mounting	Adapter, probe tip	

### Frequency response

Threaded or adhesive mounting

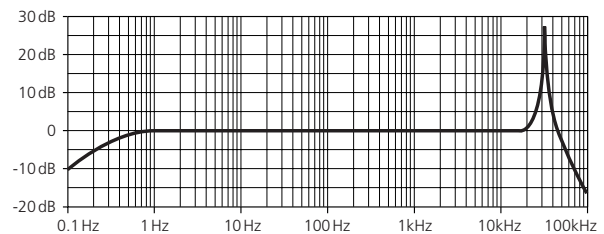

Linear frequency range is limited with

- Magnetic holder:  $\leq 5 \dots 20 \text{ kHz}$
- Probe tip:  $\leq 1 \text{ kHz}$

### Dimensions

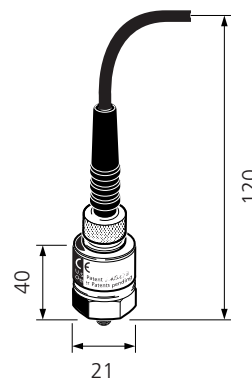

Dimensions in mm

## VIB 6.147: Mobile industrial accelerometer for low-speed machinery ( $n > 120 \text{ min}^{-1}$ )



M5 thread



Vibration acceleration

### Application

This accelerometer is suitable for vibration measurements up to 10 kHz on low-speed machinery with rotational speeds above  $120 \text{ min}^{-1}$ . High frequency shock pulse measurements for bearing condition evaluation and pump cavitation are not possible with this series.

The accelerometer is mainly used for data collection in an industrial environment. The signal acquisition and processing is carried out with a PRÜFTECHNIK data collector (e.g. VIBSCANNER, VIBXPERT II, VIBROTIP).

### Installation accessories

- VIB 3.420 Magnetic holder for curved surfaces
- VIB 3.422 Magnetic holder for flat surfaces
- VIB 3.430 Adapter for adhesive mounting
- VIB 3.435 Screwed adapter, M5-flat to M5-120°
- VIB 3.436 Screwed adapter, M5-flat to M6-90°
- VIB 3.440 Screwed adapter, M5-flat to M8-90°
- VIB 3.441 Screwed adapter, M5-flat to UNC5/16-90°
- VIB 3.450 Probe tip for accelerometer type VIB 6.14x

Installation material for adhesive mount:  
2-component adhesive (e.g. WEICON HB 300).

### Technical data

PARAMETER		VIB 6.147
Measurement	Signaling system	Current LineDrive, 3.5 mA closed current with superposed AC signal
	Transmission factor $\pm 4\%$	$5.35 \mu\text{A/ms}^{-2}$ (Ref.: 159 Hz; 25 °C)
	Frequency range $\pm 5\%$	2 Hz ... 4 kHz
	$\pm 10\%$	1 Hz ... 8 kHz
	$\pm 3\text{dB}$	0.3 Hz..12 kHz
	Resonance frequency	17 kHz; > 20 dB damped
	Linearity range $\pm 10\%$	$\pm 450 \text{ ms}^{-2}$
	Temperature range	-30 °C ... +100 °C
Electrical	Power requirement	> 10 mA / 7-18 VDC
	Transverse sensitivity	< 5% at 5 kHz
	Temperature sensitivity	< $0.01 \text{ ms}^{-2}/\text{K}$
	Magnetic sensitivity	< $1 \text{ ms}^{-2}/\text{T}$ (at 50 Hz)
	Base strain sensitivity	< $0.01 \text{ ms}^{-2}/\mu\text{m/m}$
	Electrical noise, rms	< $0.002 \text{ ms}^{-2}$ from 2 Hz
	Output impedance	> 300 kOhm
	Insulation	> $10^9 \text{ MOhm}$
Mechanical	Case material	Stainless steel VA 1.4305
	Environmental protection	IP 65 (w/ cable)
	Cable connection	TNC socket
	Shock limit	< $50 \text{ kms}^{-2}$
	Weight	38 g
Mounting	Adapter, probe tip	

### Frequency response

Threaded or adhesive mounting

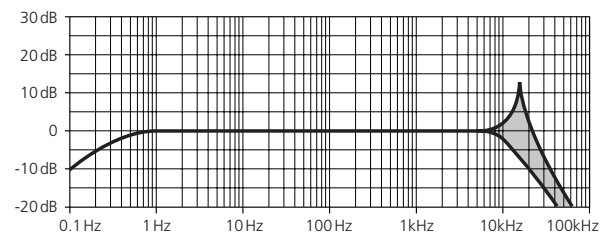

Linear frequency range is limited with

- Magnetic holder:  $\leq 5 \text{ kHz}$
- Probe tip:  $\leq 1 \text{ kHz}$

### Dimensions

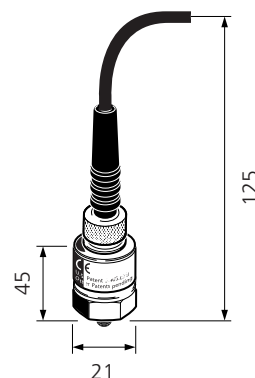

Dimensions in mm

C

## VIB 6.142 DEX: Mobile industrial accelerometer for standard machinery ( $n > 600 \text{ min}^{-1}$ ), intrinsically safe

1

2

3

4



M5 thread



Vibration acceleration



Bearing condition



Pump cavitation



CE 0044

5

6

A

### Application

This accelerometer is suitable for vibration measurements up to 20 kHz on machinery with rotational speeds above  $600 \text{ min}^{-1}$ , for shock pulse measurements on roller bearings and for cavitation measurements in pumps.

The accelerometer is mainly used for data collection in a hazardous industrial environment. The signal acquisition and processing is carried out with an intrinsically safe PRÜFTECHNIK data collector (e.g. VIBSCANNER EX, VIBXPERT EX, VIBROTIP EX, VIBTOOL).

The accelerometer is gas and dust explosion-proof. It is suitable for use with dusts having a minimum ignition temperature for 5 mm layers of not less than  $210 \text{ °C}$ .

### Notes on intrinsic safety

The accelerometers of the series VIB 6.1xx DEX may only be connected to designated devices with the following interface parameters:

$$\begin{aligned} U_{\max} &= 24\text{V} \\ P_{\max} &= 300\text{mW} \\ C_i &= 15\text{nF} \\ L_i &= \text{negligible small} \end{aligned}$$

The following documents must be considered:

- EC type examination certificate TÜV 02 ATEX 1865
- 1st supplement dated from 01.03.2007
- 2nd supplement dated from 22.06.2011

Additionally the installation notes for hazardous areas annexed in this catalog must be observed.

### Installation accessories

- |           |  |
|-----------|--|
| VIB 3.420 | Magnetic holder for curved surfaces        |
| VIB 3.422 | Magnetic holder for flat surfaces          |
| VIB 3.430 | Adapter for adhesive mounting              |
| VIB 3.435 | Screwed adapter, M5-flat to M5-120°        |
| VIB 3.436 | Screwed adapter, M5-flat to M6-90°         |
| VIB 3.440 | Screwed adapter, M5-flat to M8-90°         |
| VIB 3.441 | Screwed adapter, M5-flat to UNC5/16-90°    |
| VIB 3.450 | Probe tip for accelerometer type VIB 6.14x |

Installation material for adhesive mount:  
2-component adhesive (e.g. WEICON HB 300).

## Technical data

PARAMETER		VIB 6.142 DEX
Measurement	Signaling system	Current LineDrive, 3.5 mA closed current with superposed AC signal
	Transmission factor $\pm 3\%$	1.0 $\mu\text{A}/\text{ms}^2$ (Ref.: 159 Hz; 25 °C)
	Frequency range $\pm 5\%$	2 Hz ... 8 kHz
	$\pm 10\%$	1 Hz ... 20 kHz
	$\pm 3\text{dB}$	0.3 Hz..20 kHz
	Resonance frequency	36 kHz
	Linearity range $\pm 10\%$	$\pm 961 \text{ ms}^{-2}$
	Temperature range	-30 °C ... +80 °C
Electrical	Power requirement	> 10 mA / 7-18 VDC
	Transverse sensitivity	< 5% at 10 kHz
	Temperature sensitivity	< 0.05 $\text{ms}^{-2}/\text{K}$
	Magnetic sensitivity	< 5 $\text{ms}^{-2}/\text{T}$ (at 50 Hz)
	Base strain sensitivity	< 0.1 $\text{ms}^{-2}/\mu\text{m}/\text{m}$
	Electrical noise, rms	< 0.01 $\text{ms}^{-2}$ from 2 Hz
	Output impedance	> 300 kOhm
	Insulation	> 10 <sup>9</sup> MOhm
Mechanical	Case material	Stainless steel VA 1.4305
	Environmental protection	IP 65 (w/ cable)
	Cable connection	TNC socket
	Shock limit	< 250 $\text{kms}^{-2}$
	Weight	39 g
	Mounting	Adapter, probe tip
EX	Marking, gas explosion protection	Ex II 2 G Ex ib IIC T4
	Marking, dust expl. protection	Ex II 2 D Ex ib IIIB T <sub>5</sub> 187°C

### Frequency response

Threaded or adhesive mounting

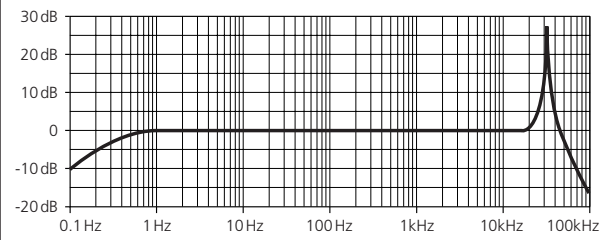

Linear frequency range is limited with

- Magnetic holder:  $\leq 5 \dots 20 \text{ kHz}$
- Probe tip:  $\leq 1 \text{ kHz}$

### Dimensions

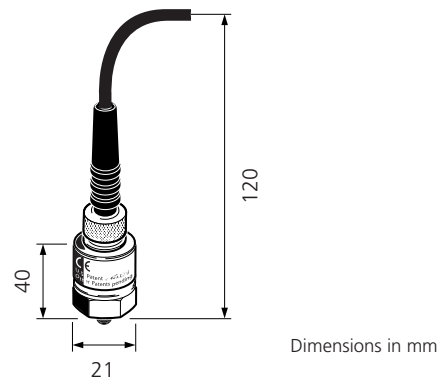

C

## VIB 6.147 DEX: Mobile industrial accelerometer for low-speed machinery ( $n > 120 \text{ min}^{-1}$ ), intrinsically safe

1

2

3



M5-Schraubgewinde



Vibration acceleration



CE 0044

4

### Application

This accelerometer is suitable for vibration measurements up to 10 kHz on low-speed machinery with rotational speeds above  $120 \text{ min}^{-1}$ . High frequency shock pulse measurements for bearing condition evaluation and pump cavitation are not possible with this series.

6

The accelerometer is mainly used for data collection in a hazardous industrial environment. The signal acquisition and processing is carried out with an intrinsically safe PRÜFTECHNIK data collector (e.g. VIBSCANNER EX, VIBXPERT EX, VIBROTIP EX, VIBTOOL).

A

The accelerometer is gas and dust explosion-proof. It is suitable for use with dusts having a minimum ignition temperature for 5 mm layers of not less than  $210 \text{ °C}$ .

### Notes on intrinsic safety

The accelerometers of the series VIB 6.1xx DEX may only be connected to designated devices with the following interface parameters:

$$\begin{aligned} U_{\max} &= 24\text{V} \\ P_{\max} &= 300\text{mW} \\ C_i &= 15\text{nF} \\ L_i &= \text{negligible small} \end{aligned}$$

The following documents must be considered:

- EC type examination certificate TÜV 02 ATEX 1865
- 1st supplement dated from 01.03.2007
- 2nd supplement dated from 22.06.2011

Additionally the installation notes for hazardous areas annexed in this catalog must be observed.

### Installation accessories

VIB 3.420	Magnetic holder for curved surfaces
VIB 3.422	Magnetic holder for flat surfaces
VIB 3.430	Adapter for adhesive mounting
VIB 3.435	Screwed adapter, M5-flat to M5-120°
VIB 3.436	Screwed adapter, M5-flat to M6-90°
VIB 3.440	Screwed adapter, M5-flat to M8-90°
VIB 3.441	Screwed adapter, M5-flat to UNC5/16-90°
VIB 3.450	Probe tip for accelerometer type VIB 6.14x

Installation material for adhesive mount:  
2-component adhesive (e.g. WEICON HB 300).



## Technical data

PARAMETER		VIB 6.147 DEX
Measurement	Signaling system	Current LineDrive, 3.5 mA closed current with superposed AC signal
	Transmission factor ± 4%	5.35 $\mu\text{A}/\text{ms}^{-2}$ (Ref.: 159 Hz; 25 °C)
	Frequency range ± 5%	2 Hz ... 4 kHz
	± 10%	1 Hz ... 8 kHz
	± 3dB	0.3 Hz.. 12 kHz
	Resonance frequency	17 kHz; > 20 dB damped
	Linearity range ± 10%	± 450 $\text{ms}^{-2}$
Electrical	Temperature range	-30 °C ... +80 °C
	Power requirement	> 10 mA / 7-18 VDC
	Transverse sensitivity	< 5% at 10 kHz
	Temperature sensitivity	< 0.01 $\text{ms}^{-2}/\text{K}$
	Magnetic sensitivity	< 1 $\text{ms}^{-2}/\text{T}$ (at 50 Hz)
	Base strain sensitivity	< 0.01 $\text{ms}^{-2}/\mu\text{m}/\text{m}$
	Electrical noise, rms	< 0.002 $\text{ms}^{-2}$ from 2 Hz
	Output impedance	> 300 kOhm
Mechanical	Insulation	> 10 <sup>9</sup> MOhm
	Case material	Stainless steel VA 1.4305
	Environmental protection	IP 65 (w/ cable)
	Cable connection	TNC socket
	Shock limit	< 50 $\text{kms}^{-2}$
	Weight	388 g
EX	Mounting	Adapter, probe tip
	Marking, gas explosion protection	Ex II 2 G Ex ib IIC T4
	Marking, dust expl. protection	Ex II 2 D Ex ib IIIB T <sub>5</sub> 187°C

### Frequency response

Threaded or adhesive mounting

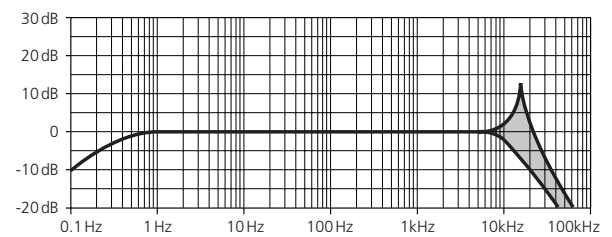

Linear frequency range is limited with

- Magnetic holder:  $\leq 5$  kHz
- Probe tip:  $\leq 1$  kHz

### Dimensions

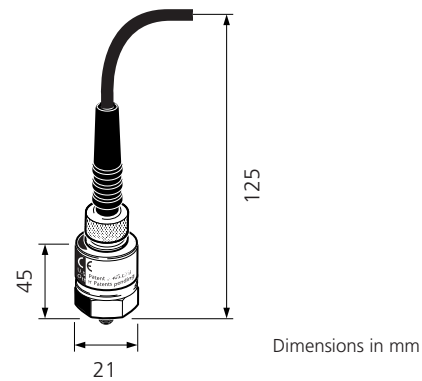

C

## Dual sensor for vibration and temperature measurement, intrinsically safe

1

VIB 6.162 VD : Dual sensor for vibration and temperature measurement with VIBSCANNER EX / VIBXPRT EX

VIB 6.162 VT : Dual sensor for vibration and temperature measurement with VIBTOOL

2

3

4

5

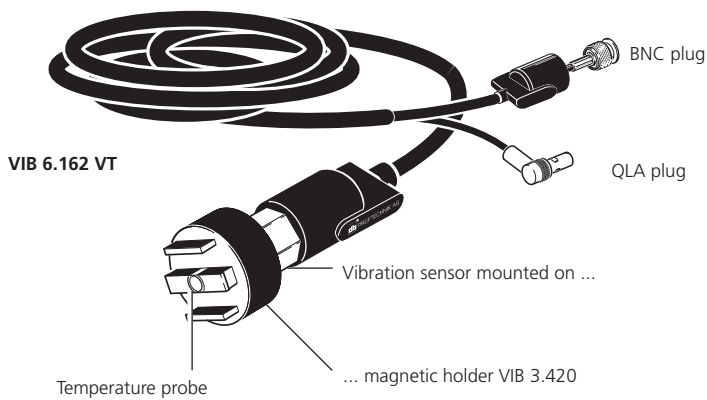

Vibration acceleration



Temperature



CE 0044

6

### Application

The dual sensor is suitable for vibration measurements up to 2 kHz and temperature measurements in the specified range. High frequency shock pulse measurements for bearing condition evaluation and pump cavitation are not possible with this sensor.

The dual sensor is mainly used for data collection in a hazardous industrial environment. The signal acquisition and processing is carried out with an intrinsically safe PRÜFTECHNIK data collector (e.g. VIBSCANNER EX, VIBXPRT EX, VIBROTIP EX, VIBTOOL).

### Installation

The dual sensor has a magnetic holder to affix it securely to ferromagnetic measurement locations - including on curved surfaces.

### Notes

During transport / storage a steel washer as a short-circuit rail is mounted on the pole pieces.

The safety data sheet is available upon request (info@pruftechnik.com) or in the Internet (www.pruftechnik.com).

### Notes on intrinsic safety

The dual sensor VIB 6.162.. consists of:  
 Mobile industrial accelerometer (intrinsically safe) VIB 6.142 DEX incl. coaxial cable and connector,  
 NiCrNi thermo couple incl. cable, connector and magnetic holder in which the thermal element is embedded.  
 The cables are bundled and the accelerometer is equipped with a protective cap. The assembled measuring device does not require a separate type examination certificate as the parts mounted on the vibration sensor are simple electrical devices in compliance with EN60079-11:2007: 5.7

### Spare part

VIB 3.420 Magnetic holder for curved surfaces

## Technical data

PARAMETER		VIB 6.162 VD	VIB 6.162 VT
Measurement, vibration	Signaling system	Current Line Drive; 3.5 mA closed current with superposed AC signal	
	Transmission factor	± 5%	1.0 $\mu\text{A}/\text{ms}^{-2}$ (Ref.: 159 Hz; 25 °C)
	Frequency range	± 10%	2 Hz ... 2 kHz
	Resonance frequency		3.7 kHz
	Linearity range	± 10%	± 961 $\text{ms}^{-2}$ (± 98 g)
	Temperature range, in hazard. area		-30 °C ... +80 °C
	-, outside hazardous area		-30 °C ... +100 °C
Electrical, vibration	Power requirement	> 3.5 mA / 7-18 VDC	
	Temperature sensitivity	< 0.05 $\text{ms}^{-2}/\text{K}$	
	Magnetic sensitivity	< 5 $\text{ms}^{-2}/\text{T}$ (at 50 Hz)	
	Electrical noise, rms	< 0.01 $\text{ms}^{-2}$ from 2 Hz	
	Output impedance	> 300 kOhm	
	Insulation	> 10 <sup>9</sup> MOhm	
Temp. sensor	Measuring system	NiCrNi	
	Transmission factor	41 $\mu\text{V}/\text{K}$	
	Accuracy	± 6% from meas. value	
	Measurement range	-30°C ... +100°C	
Mechanical	Case material	Accelerometer	Stainless steel VA 1.4305
		Magnetic holder	PA6
	Environmental protection	IP 65 (w/ cable)	
	Connection	1x QLA, 1x MiniSnap	1x QLA 1x BNC
	Shock limit	< 250 $\text{kms}^{-2}$	
	Weight	155 g	
	Mounting	Magnetic holder	
EX	Marking, gas explosion protection	⊕ II 2 G Ex ib IIC T4, T <sub>a</sub> 80°C	
	Marking, dust explosion protection	⊕ II 2 D Ex ib IIIB T <sub>5</sub> 187°C, T <sub>a</sub> 80°C	

### Frequency response magnetic coupling

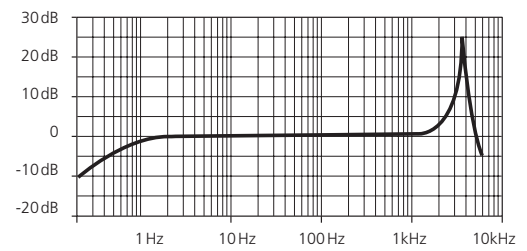

### Dimensions

in mm

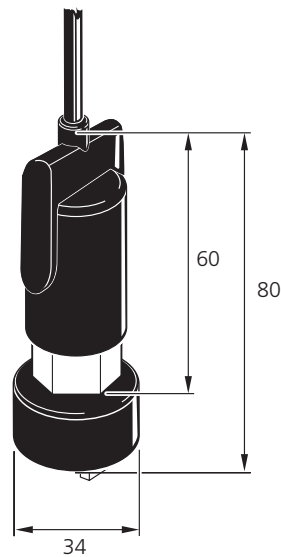

C

## TIPTECTOR handheld probe set for mobile vibration measurements

1

VIB 8.606 VS : TIPTECTOR handheld probe set for VIBSCANNER and VIBXPERT

VIB 8.606 VD : TIPTECTOR handheld probe set for VIBROTIP

2

3

4

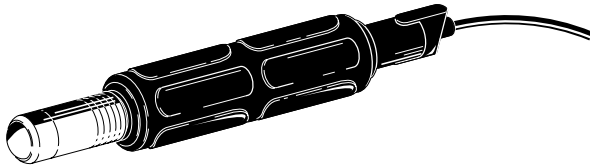

Vibration acceleration



Bearing condition



Pump cavitation

5

### Application

The TIPTECTOR handheld probe is suitable for vibration measurements up to 10 kHz on machinery with rotational speeds above 600 min<sup>-1</sup>, for shock pulse measurements on roller bearings and for cavitation measurements in pumps.

6

TIPTECTOR is mainly used for data collection in an industrial environment. The signal acquisition and processing is carried out with a PRÜFTECHNIK data collector (e.g. VIBSCANNER, VIBXPERT II, VIBROTIP).

A

The handheld probe can be extended by various grips to reach measurement locations that are inaccessible with the built-in VIBROTIP or VIBSCANNER sensor, or those which obstruct your view of the display.

### Scope of supply

The TIPTECTOR set VIB 8.606 VS contains:

VIB 8.606	TIPTECTOR probe
VIB 8.633	TIPTECTOR grip
VIB 5.436	VIBSCANNER cable

The TIPTECTOR set VIB 8.606 VD contains:

VIB 8.606	TIPTECTOR probe
VIB 8.633	TIPTECTOR grip
VIB 8.618-1.5	VIBROTIP cable, 1.5 m

### Accessories / Spare parts

VIB 8.609	TIPTECTOR grip extension, 100 mm
VIB 8.618-5	VIBROTIP cable, 5 m
VIB 8.610	PRÜFTECHNIK counter sink bit (to prepare the measurement location)

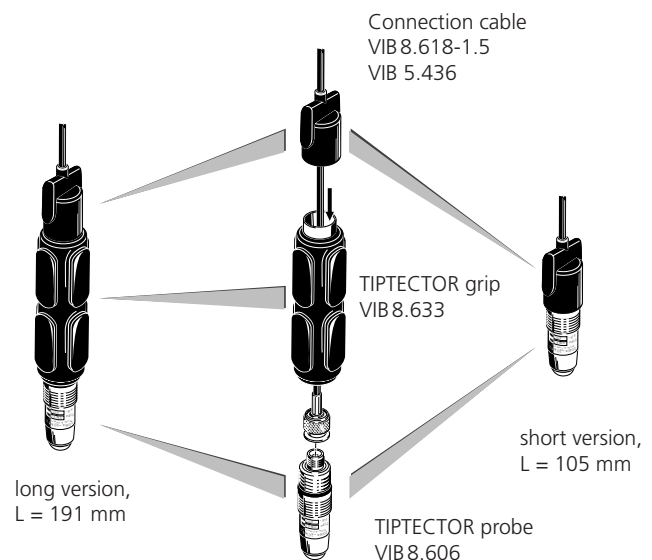

## Technical data

PARAMETER		VIB 8.606
Measurement	Signaling system	Current Line Drive; 3.5 mA closed current with superposed AC signal
	Transmission factor $\pm 2\%$	1.0 $\mu\text{A}/\text{ms}^2$ (Ref.: 159 Hz; 25 °C)
	Frequency range $\pm 10\%$	10 Hz ... 10 kHz
	Resonance frequency	36 kHz
	Linearity range	$\pm 50 \text{ ms}^{-2}$
	Temperature range	-10 °C ... +80 °C
Electrical	Power requirement	> 10 mA / 7-18 VDC
	Transverse sensitivity	< 10%
	Temperature sensitivity	< 0.3 $\text{ms}^{-2}/\text{K}$
	Magnetic sensitivity	< 14 $\text{ms}^{-2}/\text{T}$ (at 50 Hz)
	Base strain sensitivity	< 0.1 $\text{ms}^{-2}/\mu\text{m}/\text{m}$
	Electrical noise, rms	< 0.001 $\text{ms}^{-2}$ from 2 Hz
	Output impedance	> 300 kOhm
Mechanical	Case material	Stainless steel VA 1.4305
	Cable connection	TNC socket
	Shock limit	< 50 $\text{kms}^{-2}$
	Weight	75 g (short), 205 g (long)

All details apply to a measuring in the sinking. For optimal signal transmission, the measurement location should be prepared with the PRÜFTECHNIK countersink bit VIB 8.610.

### Frequency response

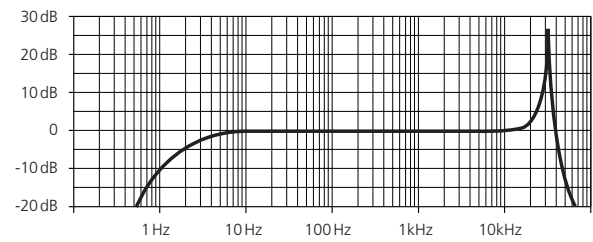

### Dimensions

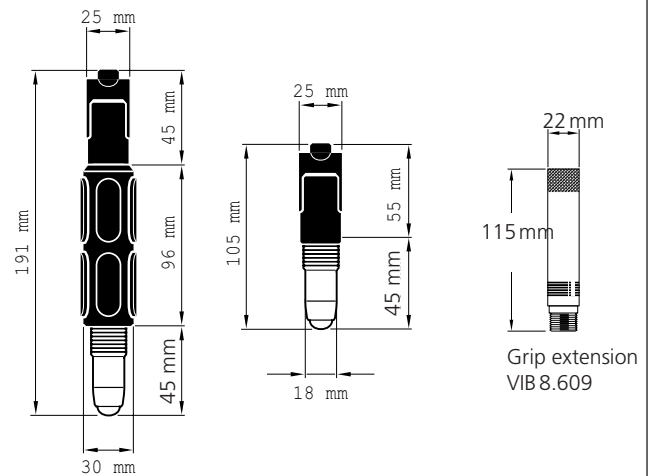

C

1

2

3

4

5

6

A

C

## TIPTECTOR handheld probe set for mobile vibration measurements, intrinsically safe

1

VIB 8.606 XVS : TIPTECTOR handheld probe set for VIBSCANNER EX, intrinsically safe

VIB 8.606 XVD : TIPTECTOR handheld probe set for VIBROTIP EX, intrinsically safe

2

3

4

5

6

A

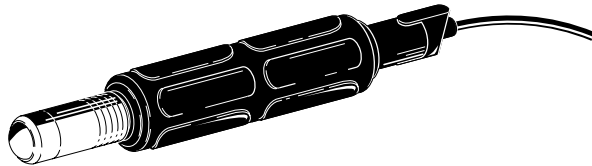

Vibration acceleration



Bearing condition



Pump cavitation



CE 0044

### Application

The TIPTECTOR handheld probe is suitable for vibration measurements up to 10 kHz on machinery with rotational speeds above 600 min<sup>-1</sup>, for shock pulse measurements on roller bearings and for cavitation measurements in pumps.

TIPTECTOR EX is mainly used for data collection in a hazardous industrial environment. The signal acquisition and processing is carried out with an intrinsically safe PRÜFTECHNIK data collector (e.g. VIBSCANNER EX, VIBROTIP EX). TIPTECTOR EX may not be used with VIBXPERT EX!

For measurements outside a hazardous area TIPTECTOR EX can also be used with data collectors without EX protection.

The handheld probe can be extended by various grips to reach measurement locations that are inaccessible with the built-in VIBROTIP or VIBSCANNER sensor, or those which obstruct your view of the display.

### Notes on intrinsic safety

The intrinsically safe TIPTECTOR probe VIB 8.606 EX may only be connected to designated devices with the following interface parameters:

$$\begin{aligned}
 U_{\max} &= 17 \text{ V} \\
 I_{\max} &= 50 \text{ mA} \\
 P_{\max} &= 300 \text{ mW} \\
 C_i, L_i &= \text{negligible small}
 \end{aligned}$$

The details in the EC type examination certificate TÜV 04 ATEX 2741 must be considered.

### Scope of supply

The TIPTECTOR set VIB 8.606 XVS contains:

VIB 8.606 EX	TIPTECTOR probe, intrinsically safe
VIB 8.633	TIPTECTOR grip
VIB 5.436	VIBSCANNER cable

The TIPTECTOR set VIB 8.606 XVD contains:

VIB 8.606 EX	TIPTECTOR probe, intrinsically safe
VIB 8.633	TIPTECTOR grip
VIB 8.618-1.5	VIBROTIP cable, 1.5 m

### Accessories / Spare parts

VIB 8.609	TIPTECTOR grip extension, 100 mm
VIB 8.618-5	VIBROTIP cable, 5 m
VIB 8.610	PRÜFTECHNIK counter sink bit (to prepare the measurement location)

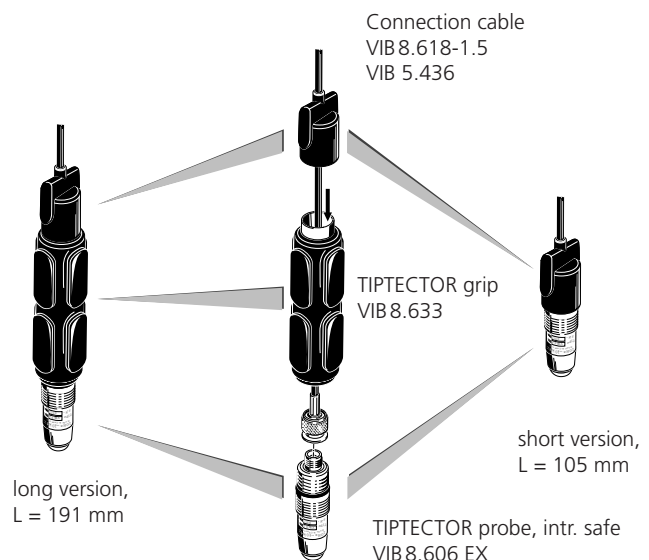

## Technical data

PARAMETER		VIB 8.606 EX
Measurement	Signaling system	Current Line Drive; 3.5 mA closed current with superposed AC signal
	Transmission factor $\pm 2\%$	1.0 $\mu\text{A}/\text{ms}^2$ (Ref.: 159 Hz; 25 °C)
	Frequency range $\pm 10\%$	10 Hz ... 10 kHz
	Resonance frequency	36 kHz
	Linearity range	$\pm 50 \text{ ms}^{-2}$
	Temperature range	-10 °C ... +80 °C
Electrical	Power requirement	> 10 mA / 7-18 VDC
	Transverse sensitivity	< 10%
	Temperature sensitivity	< 0.3 $\text{ms}^{-2}/\text{K}$
	Magnetic sensitivity	< 14 $\text{ms}^{-2}/\text{T}$ (at 50 Hz)
	Base strain sensitivity	< 0.1 $\text{ms}^{-2}/\mu\text{m/m}$
	Electrical noise, rms	< 0.001 $\text{ms}^{-2}$ from 2 Hz
	Output impedance	> 300 kOhm
Mechanical	Case material	Stainless steel VA 1.4305
	Cable connection	TNC socket
	Shock limit	< 50 $\text{kms}^{-2}$
	Weight	75 g (short), 205 g (long)
EX	Marking, gas expl. protection	 II 2 G EEx ib IIC T4

All details apply to a measuring in the sinking. For optimal signal transmission, the measurement location should be prepared with the PRÜFTECHNIK countersink bit VIB 8.610.

### Frequency response

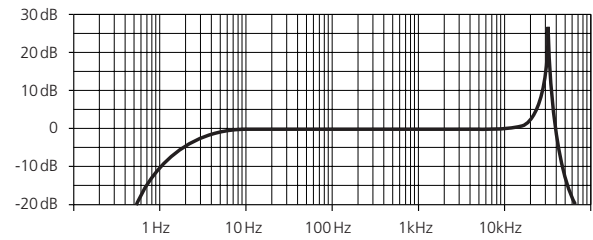

### Dimensions

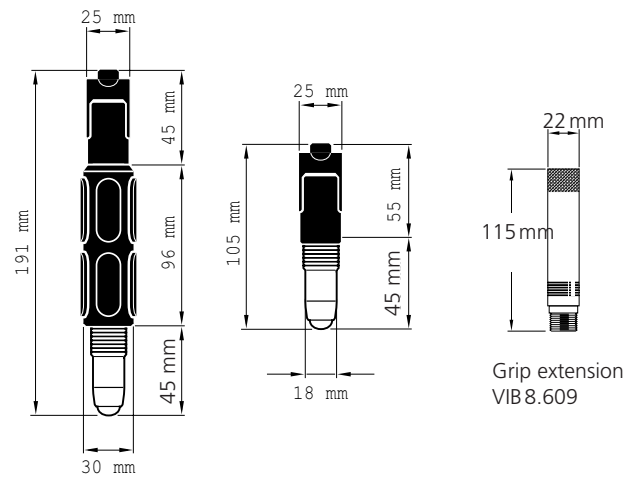

C

## Mobile accelerometers with quick fitting coupling

1

VIB 8.666 VS : Mobile accelerometer with quick fitting coupling for VIBSCANNER and VIBXPRT

VIB 8.666 VD : Mobile accelerometer with quick fitting coupling for VIBROTIP

2

3

4

5



Vibration acceleration



Bearing condition



Pump cavitation

6

A

### Application

These accelerometers are suitable for vibration measurements up to 10 kHz on machinery with rotational speeds above 600 min<sup>-1</sup>, for shock pulse measurements on roller bearings and for cavitation measurements in pumps.

The signal acquisition and processing is carried out with a PRÜFTECHNIK data collector (e.g. VIBSCANNER, VIBXPRT II, VIBROTIP).

The accelerometer locks onto the appropriate stud via its quick fitting coupling in optimum position and with consistent pressure. The rigid coupling to the stud provides optimum transmission of vibration and bearing signals (shock pulse).

### Technical data

PARAMETER		VIB 8.666 R
Measurement	Signaling system	Current Line Drive; 3.5 mA closed current with superposed AC signal
	Transmission factor ± 2%	1.0 µA/ms <sup>2</sup> (Ref.: 159 Hz; 25 °C)
	Frequency range ± 5%	1 Hz ... 10 kHz (short stud)
	Resonance frequency	36 kHz (short stud)
	Linearity range ± 10%	± 50 ms <sup>-2</sup>
	Temperature range	-30°C ... +100 °C
Electrical	Power requirement	> 10 mA / 7-18 VDC
	Transverse sensitivity	< 5% at 10 Hz
	Temperature sensitivity	< 0.05 ms <sup>-2</sup> /K
	Magnetic sensitivity	< 5 ms <sup>-2</sup> /T (at 50 Hz)
	Electrical noise, rms	< 0.01 ms <sup>-2</sup> from 2 Hz
	Output impedance	> 300 kOhm
Mechanical	Case material	Stainless steel VA 1.4305
	Environmental protection	IP 65 (w/ cable)
	Shock limit	< 250 kms <sup>-2</sup>
	Weight	28 g

### Scope of supply

The accelerometer set VIB 8.666 VS contains:  
 VIB 8.666 R Quick fit accelerometer w/o cable  
 VIB 5.436 VIBSCANNER/ VIBXPRT cable

The accelerometer set VIB 8.666 VD contains:  
 VIB 8.666 R Quick fit accelerometer w/o cable  
 VIB 321926-2 Spiral cable with QLA plug

### Spare part

VIB 8.666 R Quick fit accelerometer w/o cable

### Accessories

VIB 32000 Meas. stud M8x24, nickel-plated  
 VIB 32010 Meas. stud M8x24, Stainless steel  
 VIB 32200 Meas. stud M8x113, nickel-plated  
 VIB 32210 Meas. stud M8x113, Stainless steel  
 VIB 32310 Meas. stud M8x202, Stainless steel  
 VIB 32410 Meas. stud M8x291, Stainless steel

### Frequency response

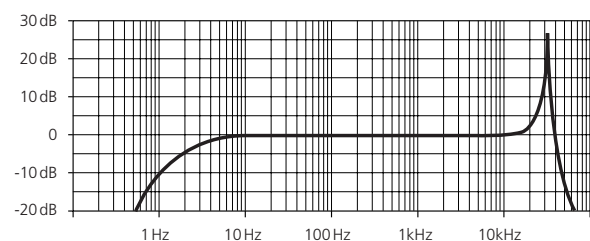

### Dimensions

in mm

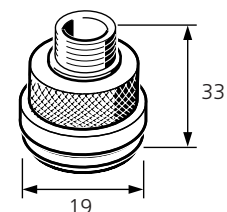



## VIB 6.655 : Triaxial accelerometer for VIBXPRT

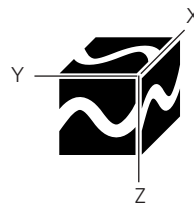
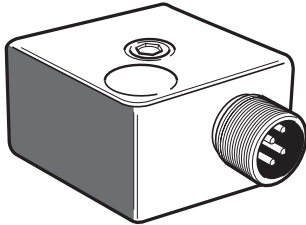

### Application

This triaxial accelerometer is used for the measurement of machine and component vibrations up to 10 kHz in the horizontal, vertical and axial directions at a single measurement location. The triaxial accelerometer achieves shorter measuring times with a data collector and is easier to install since only one sensor needs to be mounted.

### Connection

Cable adapter VIB 5.336 is needed to connect the sensor to the 2-channel VIBXPRT FFT data collector. It is not permissible to connect the sensor to VIBXPRT EX.

### Mounting

The triaxial accelerometer is attached to the machine using the magnetic holder VIB 3.420.

### Accessories

- VIB 5.336 Cable adapter for triaxial accelerometer
- VIB 3.420 Magnetic holder for curved surfaces
- VIB 3.422 Magnetic holder for flat surfaces

### Technical data

PARAMETER		VIB 6.655
Measurement	Signaling system	ICP
	Measurement range (peak.)	± 50 g
	Transmission factor ± 5%	100 mV/g
	Frequency range ± 3dB	0.6 Hz ...10kHz
	w/ magnetic holder ± 3dB	0.6 Hz ...2 kHz
	± 10%	1 Hz ...6.5 kHz
Temperature range		-54°C ... +121 °C
Electrical	Settling time	< 2.5 s
	Power requirement	2-10 mA / 18-30 VDC
	Spectral noise, @ 10 / 100 / 1000 Hz	27 / 6.5 / 2.5 µg / (Hz) <sup>1/2</sup>
	Output impedance	< 100 Ohm
	Case insulation	> 10 <sup>8</sup> Ohm
	Bias output voltage	11-13 VDC
Mechanical	Case material	Stainless steel 316L
	Mounting	M5x1 captive bolt
	Mounting torque	1.4 bis 2.7 Nm
	Connector type	Cable connector, 4-pole (Mini-MIL)
	Weight	200 g

### Dimensions

in mm

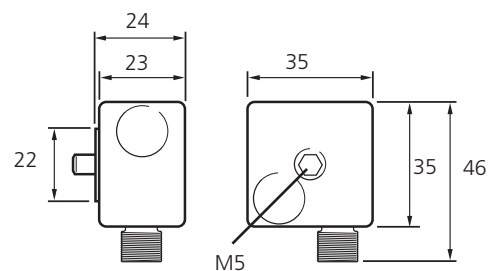

### Connection example

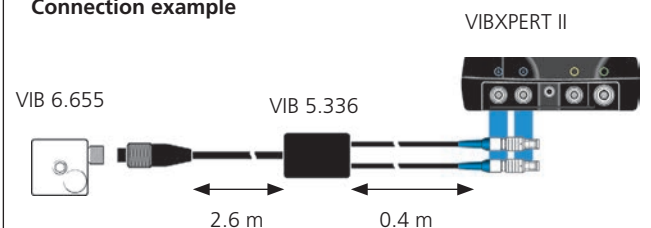

C

## Temperature probes for PRÜFTECHNIK data collectors

1

VIB 8.605 : Built-in temperature probe for VIBROTIP / VIBSCANNER (spare part)

VIB 8.607-1,5 : Temperature probe with magnetic holder, 1.5 m

VIB 8.608 : Handheld temperature probe

2

3

4

5

6

A



VIB 8.605



Temperature

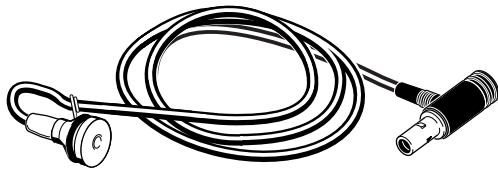

VIB 8.607-1,5



VIB 8.608

### Description

Temperature probes for PRÜFTECHNIK data collectors include a thermocouple type K, which can be used for temperature measurements up to 500 °C.

### Application

The temperature probe VIB 8.605 is a spare part for VIBROTIP's or VIBSCANNER's built-in temperature probe. It can be easily replaced by pressing a button. Its flexible, rubberized neck allows optimum contact with the measurement location and temperature measurements in liquids.

The temperature probe with magnetic holder VIB 8.607-1,5 is used to reach poorly-accessible measurement lo-

cations, which are not accessible with VIBROTIP's or VIBSCANNER's built-in temperature probe. The powerful magnet makes for extremely quick and simple mounting.

The handheld temperature probe VIB 8.608 measures up to 500°C. The long, narrow probe tip allows measurements even at hard to reach locations.

### Notes

Applies to VIB 8.607-1,5:

During transport / storage a steel washer as a short-circuit rail is mounted on the pole pieces.

The safety data sheet is available upon request (info@pruftechnik.com) or in the Internet (www.pruftechnik.com).

## Technical data

PARAMETER		VIB 8.605	VIB 8.607-1,5	VIB 8.608
Measurement	Type	Thermocouple type K		
	Meas. range	-30°C.. +270°C	-50°C ... +240°C	-50°C ... +500°C
	Sensitivity	--	0.040 mV/°C	
	Accuracy	< 3%		
Mechanical	Dimensions (L x Ø)	25 mm x 11 mm	14 mm (Ø)	250 mm x 3 mm
	Cable length	--	1,5 m	--
	Weight	6 g	28 g	83 g
	Connector	QLA plug		

### Application examples

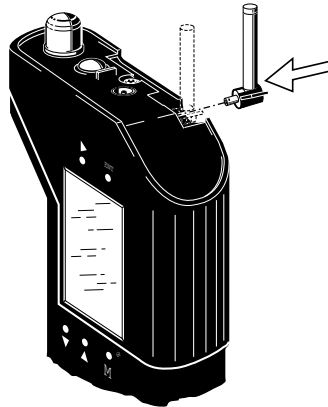

Replacing the internal VIBROTIP temperature probe VIB 8.605

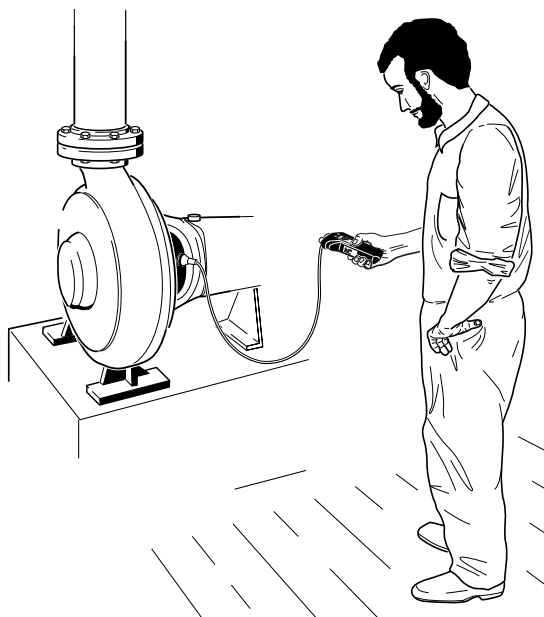

Temperature probe VIB 8.607-1,5 used with VIBROTIP

## C VIB 6.631 : Laser trigger / Laser RPM sensor

1

Laser / Sensor



2

3



RPM / Trigger

4

### Application

This sensor is used as a trigger for vibration measurements and for RPM measurements.

5

### Description

The sensor detects the signals optically, i.e. without having contact with rotating machine parts during the measurement. Red laser light is emitted from the sensor head and impinges on a mark on the rotating shaft. The mark can be light reinforcing (e.g. reflective tape VIB 3.306) or light damping (e.g. black, high-contrast line on a bright surface). Every time the optical system measures a brightness contrast, the sensor emits an electrical pulse. The data collector (VIBXPRT, VIBSCANNER) calculates the shaft speed based on the rate of repetition of this voltage pulse.

6

A

### Installation and adjustment

The sensor is mounted on the machine using the trigger stand (VIB 6.632). To adjust the sensor, the laser beam is pointed toward the measurement mark while the machine is at a standstill. As far as possible, the laser beam should be slightly inclined to the shaft surface and shaft axis.

### Safety notes

- Do not stare into the laser beam!
- Do not open the housing!

### Cleaning instructions

- Clean the lens with a moist cloth.
- Use water only. Do not use alcohol of any kind!
- Protect the lens from contamination with skin grease. Avoid direct contact. Do not touch with areas of the cloth that were previously touched.

### Accessories

- VIB 6.632 Trigger stand
- VIB 5.432-2,9 Trigger cable
- VIB 3.306 Reflective tape (measurement mark)

### Technical data

PARAMETER		VIB 6.631
Measurement	Measurement principle	optical
	Measurement range	0.1 ... 600'000 1/min.
	Measurement distance w/ reflective mark	0.05 ... 2 m
		w/ contrast mark
	Temperature range	-20 °C ... +50 °C
Electrical	Power requirement	< 5.8 V (from device)
	Output	5 V (TTL)
	Laser wave length	670 nm (red)
	Laser class	2 (DIN EN 60825-1, May 2008)
Mechanical	Connection	Trigger cable VIB 5.432-2,9
	Environmental protection	IP 65
	Weight	72 g
	Dimensions	see drawing

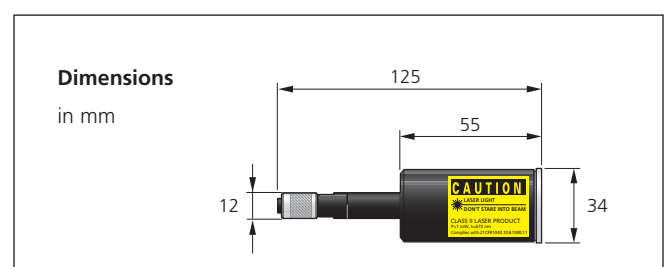

**Typical setup**

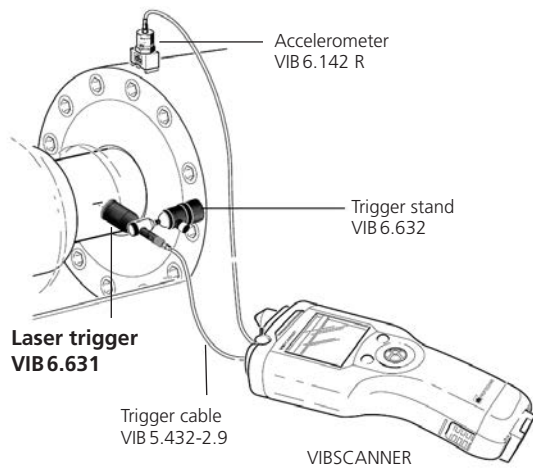

**Signal response**

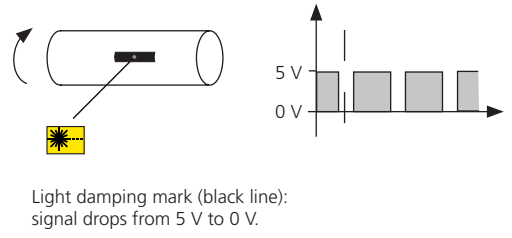
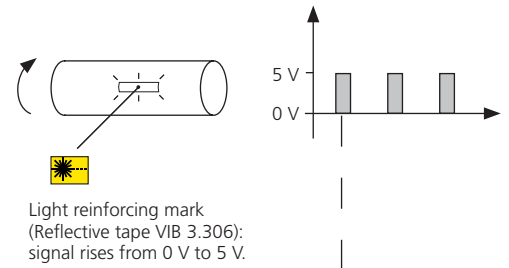

**Adjusting**

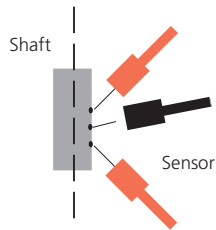

Acceptable angular deviation:  
± 45° (Reflective mark)  
± 15° (Contrast mark)

- C
- 1
- 2
- 3
- 4
- 5
- 6
- A

C

## VIB 6.631 EX: Laser trigger / Laser RPM sensor, intrinsically safe

1

2

3

Laser / Sensor



4

### Application

This sensor is used as a trigger for vibration measurements and for RPM measurements in a hazardous industrial environment. The signal acquisition and processing is carried out with an intrinsically safe PRÜFTECHNIK data collector (e.g. VIBSCANNER EX, VIBXPERT EX).

5

For measurements outside a hazardous area the sensor can also be used with data collectors without EX protection.

6

### Description

The sensor detects the signals optically, i.e. without having contact with rotating machine parts during the measurement. Red laser light is emitted from the sensor head and impinges on a mark on the rotating shaft. The mark can be light reinforcing (e.g. reflective tape VIB 3.306) or light damping (e.g. black, high-contrast line on a bright surface). Every time the optical system measures a brightness contrast, the sensor emits an electrical pulse. The data collector (VIBXPERT, VIBSCANNER) calculates the shaft speed based on the rate of repetition of this voltage pulse.

A

### Installation and adjustment

The sensor is mounted on the machine using the trigger stand (VIB 6.632). To adjust the sensor, the laser beam is pointed toward the measurement mark while the machine is at a standstill. As far as possible, the laser beam should be slightly inclined to the shaft surface and shaft axis.

### Accessories

VIB 6.632	Trigger stand
VIB 5.432-2,9	Trigger cable
VIB 3.306	Reflective tape (measurement mark)

### Safety notes

- Do not stare into the laser beam!
- Do not open the housing!

### Cleaning instructions

- Clean the lens with a moist cloth.
- Use water only. Do not use alcohol of any kind!
- Protect the lens from contamination with skin grease. Avoid direct contact. Do not touch with areas of the cloth that were previously touched.

### Notes on intrinsic safety

The intrinsically safe laser trigger sensor of the series VIB 6.631 EX is only for „connection to a compatible measuring device/operating equipment with a separate EG type examination certificate“ or „for connection to certified intrinsically safe circuits that do not exceed the following maximum values:

$U_{max}$	12V DC
$P_{max}$	600 mW
$I_{i,max}$	160 mA
$C_i$	328 nF
$L_i$	negligible small

The details in the EC type examination certificate Zelm 10 ATEX 0429 must be considered.

Additionally the installation notes for hazardous areas annexed in this catalog and the european installation instructions must be followed (EN 60079-14:2003).

### Permissible cable

Cable for laser trigger sensor - VIB 5.432-2,9

### Service and maintenance

Service and maintenance cannot be performed on the sensor. If the sensor is damaged, it must be immediately removed from the hazardous area.

## Technical data

PARAMETER		VIB 6.631 EX
Measurement	Measurement principle	optical
	Measurement range	0.1 ... 600'000 1/min.
	Measurement distance w/ reflective mark	0.05 ... 2 m
		w/ contrast mark
	Temperature range	-20 °C ... +50 °C
Electrical	Power requirement	< 5.8 V (from device)
	Output	5 V (TTL)
	Laser wave length	670 nm (red)
	Laser class	2 (DIN EN 60825-1, May 2008)
Mechanical	Connection	Trigger cable VIB 5.432-2,9
	Environmental protection	IP 65
	Weight	72 g
	Dimensions	see drawing
EX	Marking	 II 2 G Ex ib op is IIC T4

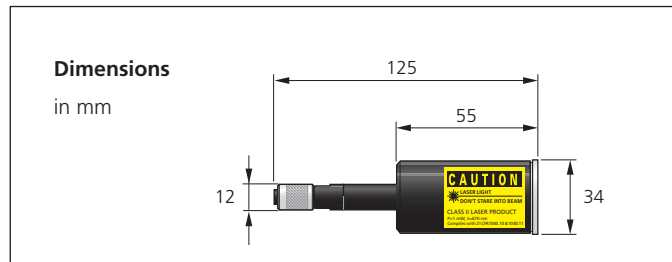

### Typical setup

in hazardous areas

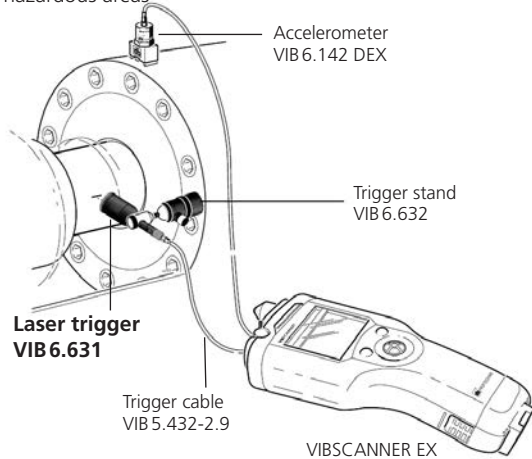

### Signal response

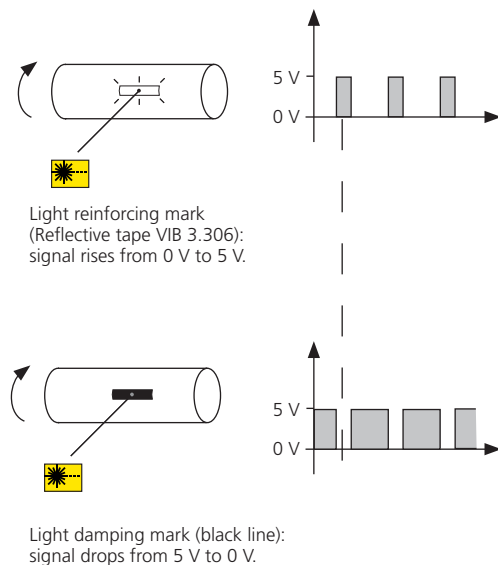

### Adjusting

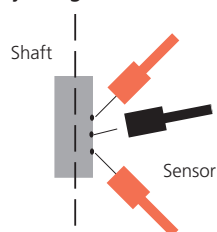

Acceptable angular deviation:  
± 45° (Reflective mark)  
± 15° (Contrast mark)

C

## VIB 6.640: Inductive proximity sensor for VIBXPRT incl. cable (3-15 mm)

1

2

3

4



Displacement / Expansion

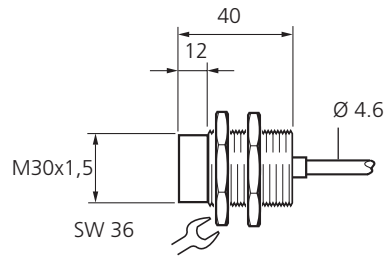

Dimensions in mm

5

### Application

The proximity sensor is used for contact-free measuring the gap of metallic objects within the specified range (3 - 15 mm).

6

### Function

The sensor is suitable for measurements without the highest precision requirements. The linearization of the characteristic curve is automatically done in the VIBXPRT data collector.

A

### Mounting

The through tapped hole enables the simple mounting and positioning of the sensor. The following notes according to EN 60947-5-2 for non-flush mounting in metal must be observed:

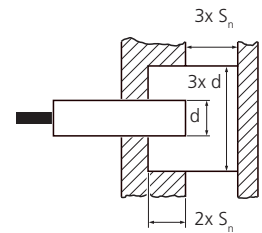

### Technical data

PARAMETER		VIB 6.640
Measurement	Measuring principle	Inductive
	Measurement variable	relative displacement / expansion
	Working range $S_n$	3 ... 15 mm
	Linearity	$\leq 5\%$
	Repeatability	$\leq 1\%$
	Average rise	0.333 V/mm $\pm 5\%$
	Max. frequency	300 Hz
	Influence $U_b$ on $U_a$ $dU_a/dU_b$	approx. 6.7% / 0.1V
	Temperature range	-25 °C ... +70 °C
Temperature drift	$\pm 5\%$	
Electrical	Operating voltage $U_b$	5 VDC, stabilized
	Operating current	$\leq 15\text{mA}$
	Output signal $U_a$	0.5 .. 4.5 VDC (see characteristic)
	Load resistance	$\geq 20\text{kOhm}$
Mechanical	Case material	Brass, nickel-plated
	Material of active surface	PCP
	Environmental protection	IP 67
	Installation	Non-flush
	Connection	Cable with MiniSnap connector, 2.9 m long

### Characteristic

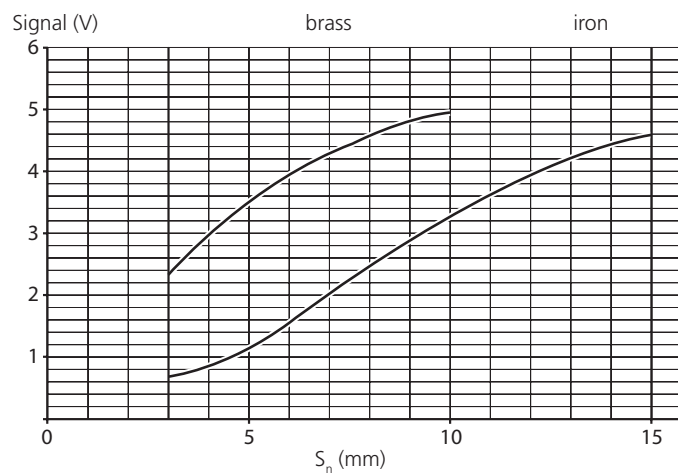

### Connection diagram





## VIB 6.672: LED stroboscope

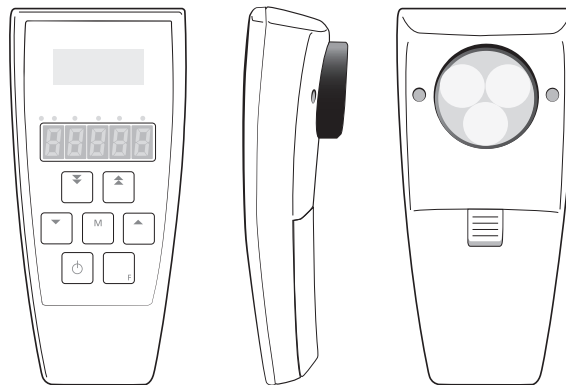

### Application

This handy stroboscope is used together with the VIBXPERT FFT analyzer to analyze rotary motion and to measure phase shift, rotational speed and velocity.

### Function

The stroboscope uses bright LEDs. The flash frequency can be controlled internally or set via an external trigger signal

### Scope of delivery

- LED stroboscope
- Trigger cable 1.5 m incl. BNC connector
- Hard shell box
- Set of batteries (2x AA / LR6)
- Manual

### Technical data

PARAMETER		VIB 6.672
Measurement	Light source	3 CREE diodes
	Light intensity	3800 Lux max. (@ 50 Hz / 20 cm)
	Frequency range	1 - 2000 Hz / 60 - 99999 min <sup>-1</sup>
	Control of the flash rate	Internal: key pad External: external trigger signal
	Phase shifting	0 - 360°
	Operating temperature	0 ... +40 °C
	Operating time	< 15h
General	Dimensions	140 x 63 x 38 mm
	Weight	175 g
	Storage temperature	-20 °C ... +70 °C
	Rel. humidity	< 80% at 30 °C
	Protection class	IP 40

### Application example

VIBXPERT II with stroboscope VIB 6.672

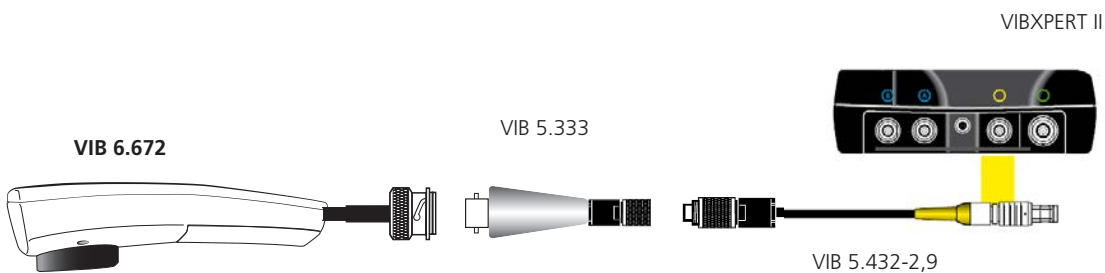

C

## VIB 6.673: Current clamp (400A AC/ 600A DC)

1

2

3

4

5

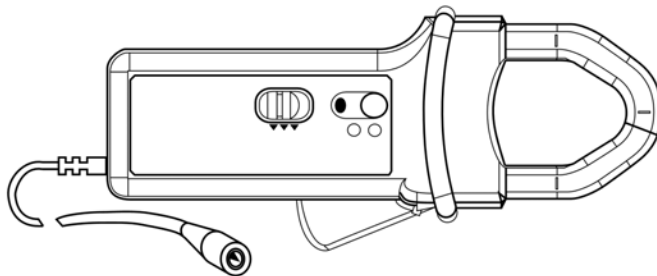

6

### Application

This current clamp connects to the VIBXPERT II FFT analyzer and is used for AC/DC current measurement, power measurement and True RMS measurement with DC component.

A

### Function

The current clamp uses the Hall-effect principle. A push button operates the automatic DC zeroing.

### Connection

The cable adapter for signal low voltage (VIB 5.433) is required to connect the current clamp to VIBXPERT II.

### Scope of supply

Current clamp, 9V battery, manual

### Application example

VIBXPERT II and current clamp VIB 6.673

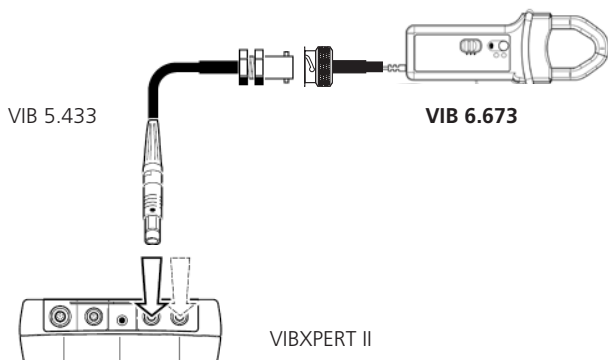

### Technical data

PARAMETER		VIB 6.673	
Electrical	Calibre	60 A	600 A
	Current range	0.2 ... 40A AC 0.4 ... 60A DC	0.5 ... 400A AC 0.5 ... 600A DC
	Output signal	10mV/A	1mV/A
	Accuracy*	0.5..40A: 1.5% ±5mV 40 ... 60A DC: 1.5%	0.5..100A: 1.5% ±1mV 100 .. 400A DC: 2% 400 .. 600A DC: 2.5%
	Phase shift (45 - 65 Hz)*	10 ... 20A : < 3° 20 ... 40A : < 2°	10 ... 100A : < 2° 100...400A : < 1.5°
	Noise	DC ... 1 kHz : < 8mV DC ... 5 kHz : < 12mV 0.1 Hz ..5 kHz : < 2mV	DC ... 1 kHz : < 1mV DC ... 5 kHz : < 1,5mV 0.1Hz...5 kHz : < 0.5mV
	Rise/ Fall time	≤ 100µs from 10 to 90% of the voltage value	≤ 70µs from 10 to 90% of the voltage value
	Overload	2000 A DC / 1000 A AC up to 1kHz	
	Bandwidth	DC ... 10 kHz at -3dB	
	Load impedance	≥ 1MΩ and ≤ 100pF	
	Operating voltage	600 V RMS	
	Battery	9V alkaline (NEDA 1604 A, IEC 6LR61)	
	Low battery signal	Green LED when battery voltage > 6.5 V	
	Battery life	approx. 50 hours	
	Overload indicator	Red LED	
Autom. switch-off	10 minutes non-use		
Mechanical	Operat. temperature	-10°C .. +55°C	
	DC zero adjustment	Automatically operated by button (±10A)	
	Max. jaw insertion	1 cable Ø 30mm or 2 cables Ø 24 mm	
	Protection rating	IP 30	
	Dimensions	224x97x44 mm	
Weight	440g		
Connection	Coaxial cable, 2 m, BNC plug		

\* Conditions of reference:  
18° at 28°C, 20 to 75% RH, 48 to 65 Hz, external magnetic field < 40 A/m, no DC component, no current-carrying conductor nearby, centred test sample, charge ≥ 1 MΩ and ≤ 100 pF, reset to zero before measurement (only DC) DC to 65 Hz, batteries 9 V ±0.1 V



C

## Contents: Mounting adapters and tools

1

2

3

4

5

6

A

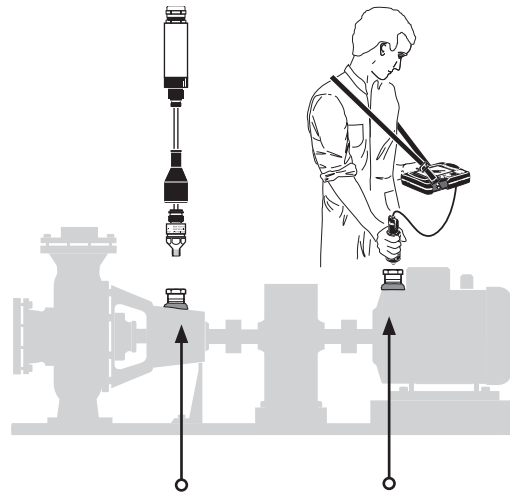

Order no.	Description	Page
VIB 3.411 VIB 3.412 VIB 3.413 VIB 3.414 VIB 3.415 VIB 3.416	Screwed adapter with locking nut for industrial accelerometers -, M8 to M8 -, M8 to M10 -, M8 to M12 -, UNC 5/16 to UNC 5/16 -, UNC 5/16 to UNC 3/8 - 16 -, UNC 5/16 to UNC 1/2 - 13	93
VIB 3.417-M5 VIB 3.417-M6	Screwed adapter for mini accelerometer, -, UNF1/4 to M5 -, UNF1/4 to M6	94
VIB 3.418 VIB 3.431 VIB 3.432 VIB 3.433	Adhesive adapter for -, mini accelerometer -, industrial accelerometer, M8-90° -, industrial accelerometer, UNC 5/16 -, CLD-/ICP-type accelerometer and VIBROTECTOR vibration transmitter	96
VIB 3.437 VIB 3.438 VIB 3.439	Screwed adapter for CLD-/ICP-type accelerometer and VIBROTECTOR -, UNF 1/4 to M8/90° -, UNF 1/4 to M8 -, UNF 1/4 to M5	94
VIB 3.474 VIB 3.475 VIB 8.772	Screwed adapter for industrial accelerometers, -, M8-90° to M16 -, M8-90° to M20 -, M8-90° to M10-120°	95
VIB 3.480	M8 thread for CLD-/ICP-type accelerometer and VIBROTECTOR vibration transmitter	94
VIB 8.586 VIB 8.587 VIB 8.588 VIB 8.589 VIB 8.590 VIB 8.591 VIB 8.592	Extension post for industrial accelerometer -, M8 x 55 mm -, M8 x 95 mm -, M8 x 170 mm -, M8 x 35 mm -, UNC 5/16 x 2 1/8" -, UNC 5/16 x 3 3/4" -, UNC 5/16 x 6 5/8"	98
VIB 8.693 VIB 8.694 VIB 8.696	M8 thread tap 90° counter sink bit UNC5/16 thread tap	107

Order no.	Description	Page
VIB 3.306	Reflective tape for laser trigger	104
VIB 3.420 VIB 3.422 VIB 3.423	Magnetic holder for -, curved surfaces, M5 -, flat surfaces, M5 -, flat surfaces, ¼-28 UNF	97
VIB 3.430	Adhesive adapter, M5	96
VIB 3.435 VIB 3.436 VIB 3.440 VIB 3.441	Screwed adapter -, M5-flat to M5-120° -, M5 to M6 -, M5 to M8 -, M5 to UNC 5/16	95
VIB 3.450	Probe tip, M5	106
VIB 6.632	Stand for laser trigger / laser RPM sensor	104
VIB 8.563 A25 VIB 8.566 VIB 8.568	VIBCODE code ring, 25 pcs. Protective cap for VIBCODE stud Color coding for protective cap	103
VIB 8.571 VIB 8.572 VIB 8.573 VIB 8.594 VIB 8.595 VIB 8.596	VIBCODE meas. stud w/ locking nut -, M8 -, M10 -, M12 -, UNC 5/16-18 -, UNC 3/8-16 -, UNC 1/2-13	101
VIB 8.576 VIB 8.577 VIB 8.578 VIB 8.580 VIB 8.581 VIB 8.582	VIBCODE meas. stud w/ extension post -, M8 x 55 -, M8 x 95 -, M8 x 170 -, UNC 5/16 x 2 1/8" -, UNC 5/16 x 3 3/4" -, UNC 5/16 x 6 5/8"	100
VIB 8.610	PRÜFTECHNIK counter sink bit	107
VIB 8.679 SET VIB 8.680 SET	VIBCODE meas. stud -, M8, VA 1.4571 -, M8, VA 1.4305	99
VIB 8.685 SET	VIBCODE measurement stud for adhesive mounting	102
VIB 8.689 SET VIB 8.690 SET	VIBCODE meas. stud -, UNC 5/16, VA 1.4571 -, UNC 5/16, VA 1.4305	99
VIB 8.692	VIBCODE encoding tool	103
VIB 32000 VIB 32010 VIB 32200 VIB 32210 VIB 32310 VIB 32410 VIB 33000A25	Meas. stud for accelerometer VIB 8.666 -, M8x24, nickel-plated -, M8x24, stainless steel -, M8x113, nickel-plated -, M8x113, stainless steel -, M8x202, stainless steel -, M8x291, stainless steel -, adhesive mount	105
VIB 81025	Protective cap for measurement stud	105

## Screwed adapters with locking nut

VIB 3.411 :	Screwed adapter with locking nut, M8 to M8
VIB 3.412 :	Screwed adapter with locking nut, M8 to M10
VIB 3.413 :	Screwed adapter with locking nut, M8 to M12
VIB 3.414 :	Screwed adapter with locking nut, UNC 5/16 to UNC 5/16
VIB 3.415 :	Screwed adapter with locking nut, UNC 5/16 to UNC 3/8 - 16
VIB 3.416 :	Screwed adapter with locking nut, UNC 5/16 to UNC 1/2 -13

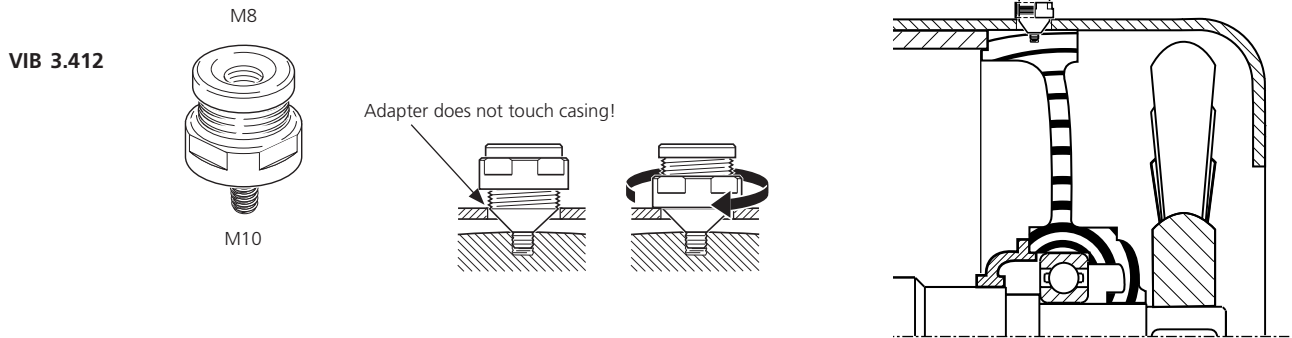

### Application

The adapter with locking nut is ideal for situations such as motor housings where there is little clearance between the actual mounting location (e.g. the bearing housing) and the machine housing. This arrangement can even be used to replace existing housing screws. Once the adapter is torqued into the threaded hole prepared for measurement, the counter nut can be tightened against the machine housing.

To ensure optimum signal transmission, the cone of the bolt may only touch the measuring point (e.g. the bearing housing), but not the metal casing.

### Material

Stainless steel, VA1.4305

### Installation accessories

VIB 8.693	M8 screw tap
VIB 8.696	UNC 5/16 screw tap
VIB 8.694	90° countersink bit

### Mounting instructions

dimensions in mm

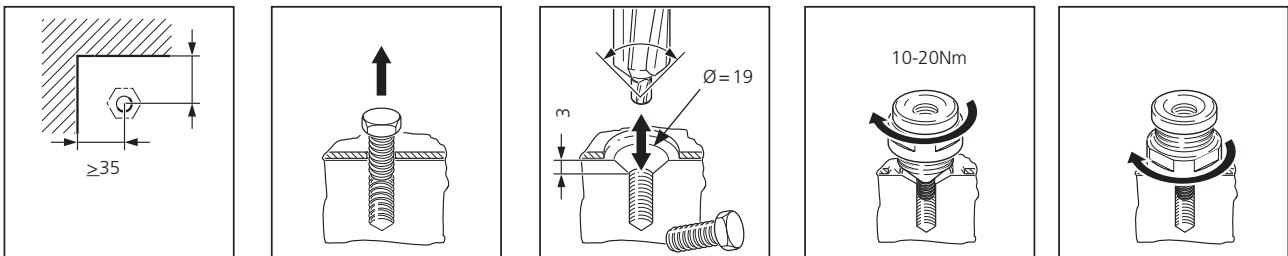

Ensure sufficient clearance

Remove bolt and housing cowling

Countersink hole, bore cowling

Mount adapter

Fasten locking nut

### Height

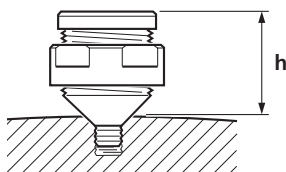

Adapter Order no.	Height h in mm
VIB 3.413 / VIB 3.416	16
VIB 3.412 / VIB 3.415	17
VIB 3.411 / VIB 3.414	18

## C Screwed adapters for accelerometers

1

VIB 3.417-M5 : Screwed adapter for mini accelerometer, UNF 1/4 to M5-flat

VIB 3.417-M6 : Screwed adapter for mini accelerometer, UNF 1/4 to M6-flat

2

VIB 3.437 : Screwed adapter for CLD- /ICP-type accelerometer and VIBROTECTOR, UNF 1/4 to M8-90°

VIB 3.438 : Screwed adapter for CLD- /ICP-type accelerometer and VIBROTECTOR, UNF 1/4 to M8-flat

VIB 3.439 : Screwed adapter for CLD- /ICP-type accelerometer and VIBROTECTOR, UNF 1/4 to M5-flat

3

VIB 3.480 : M8 thread for CLD- /ICP-type accelerometer and VIBROTECTOR vibration transmitter

4

5

6

A

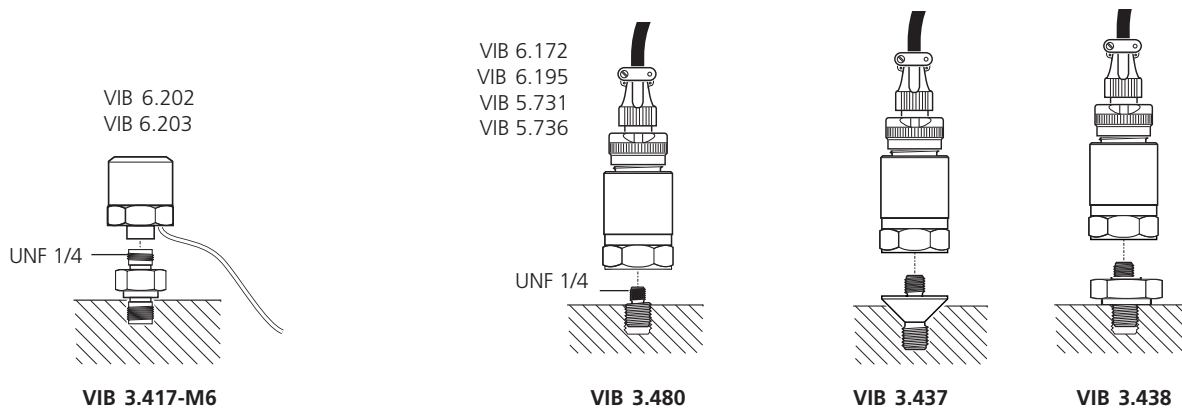

### Application

The adapters VIB 3.417-M5 / M6 and VIB 3.437 to VIB 3.439 are used for the installation of accelerometers in existing threads of the appropriate size.

The M8 threaded adapter VIB 3.480 is standard in the CLD / ICP-type accelerometers and in the VIBROTECTOR vibration transmitter.

### Material

Stainless steel, VA1.4305

### Installation accessories

VIB 8.693 M8 screw tap  
VIB 8.694 90° countersink bit

### Dimensions in mm

Adapter order no.	Installation height h	Thread size s	Thread length l	Width across flats, AF
VIB 3.480	0	M8	11	--
VIB 3.417-M5	11	M5	5	13
VIB 3.417-M6	11	M6	6	13
VIB 3.437	4	M8-90°	5	--
VIB 3.438	8	M8	4	22
VIB 3.439	1	M5	4	--

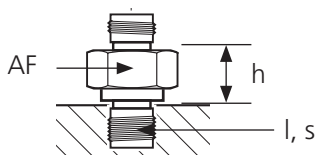

## Screwed adapters for industrial accelerometers

VIB 3.435 : Screwed adapter for mobile industrial accelerometer, M5-flat to M5-120°

VIB 3.436 : Screwed adapter for mobile industrial accelerometer, M5-flat to M6-90°

VIB 3.440 : Screwed adapter for mobile industrial accelerometer, M5-flat to M8-90°

VIB 3.441 : Screwed adapter for mobile industrial accelerometer, M5-flat to UNC5/16-90°

VIB 3.474 : Screwed adapter for industrial accelerometer, M8-90° to M16

VIB 3.475 : Screwed adapter for industrial accelerometer, M8-90° to M20

VIB 8.772 : Screwed adapter for industrial accelerometer, M8-90° to M10-120°

VIB 6.122R

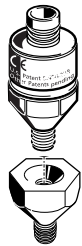

VIB 8.772

VIB 6.142R



VIB 3.435

VIB 6.122R

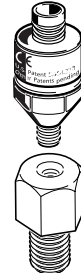

VIB 3.474

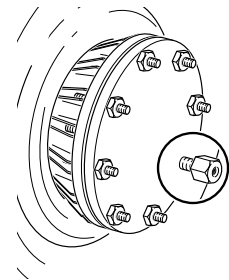

### Application

The adapters VIB 3.435 to VIB 3.441 are used for the installation of industrial accelerometers of the series VIB 6.1xx in existing threads of the appropriate size.

The adapters VIB 3.474 and VIB 3.475 are used for the permanent installation of accelerometers for monitoring the bearings in turbochargers. The adapter replaces a screw on the turbocharger. When selecting the accelerometer and cabling, bear in mind the high temperature range (approx. 130°C) of the turbocharger.

Journal bearings cannot be monitored using these adapters.

The adapter VIB 8.772 is used to install an industrial accelerometer (M8 thread) into an existing M10 hole, e.g. jack ring thread on a motor.

### Material

Stainless steel, VA1.4305

### Installation accessories

VIB 8.693 M8 screw tap

VIB 8.696 UNC 5/16 screw tap

VIB 8.694 90° countersink bit

### Dimensions in mm

Adapter order no.	Installation height h	Thread size s	Thread length l	Width across flats, AF
VIB 3.435	8	M5-120°	3.5	19
VIB 3.436	8	M6-90°	6	19
VIB 3.440	9	M8-90°	5	19
VIB 3.441	9	UNC 5/16-90°	5	19
VIB 3.474	27	M16	65	30
VIB 3.475	27	M20	45	30
VIB 8.772	12	M10-120°	7	19

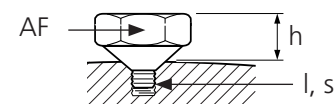

### Mounting instructions for VIB 3.440 / VIB 3.441

dimensions in mm

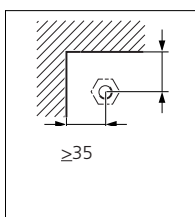

Select position

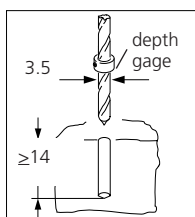

Bore pilot hole

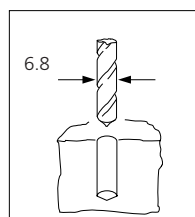

Bore out hole

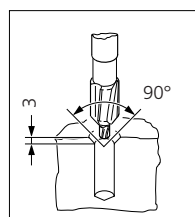

Countersink

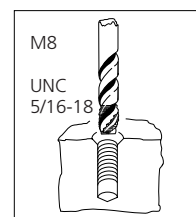

Tap thread

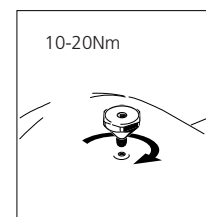

Mount adapter

C

**Adhesive adapters for accelerometers**

1

VIB 3.418 : Adhesive adapter for mini accelerometer, UNF 1/4 thread

VIB 3.430 : Adhesive adapter for mobile industrial accelerometer, M5-flat

VIB 3.431 : Adhesive adapter for industrial accelerometer, M8-90°

2

VIB 3.432 : Adhesive adapter for industrial accelerometer, UNC 5/16-90°

VIB 3.433 : Adhesive adapter for CLD-/ICP-type accelerometer and VIBROTECTOR vibration transmitter

3

VIB 6.202  
VIB 6.203

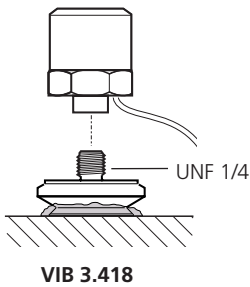

VIB 3.418

VIB 6.172  
VIB 6.195  
VIB 5.731 / 36

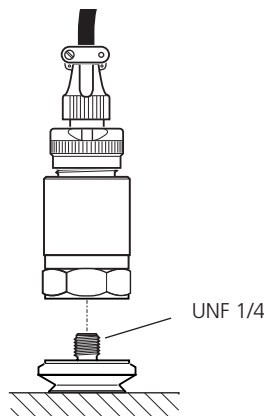

VIB 3.433

VIB 6.142R

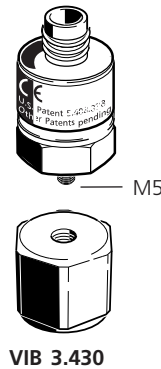

VIB 3.430

VIB 6.122R

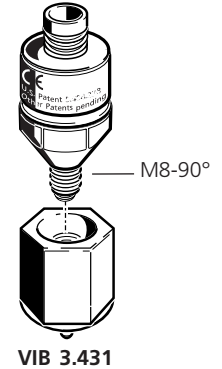

VIB 3.431

Adhesive connection patented  
U.S. patents 6,706,367 / 6,805,943 B2

A

**Application**

These adapters are ideal when only adhesive mounting is possible.

**Material**

Stainless steel, VA1.4305

**Mounting notes**

A removable self-threading centering pin may be used if desired to hold the adapter in place while the adhesive cures to final hardness.

Installation material for adhesive mount:  
2-component adhesive (e.g. WEICON HB 300).

**Mounting instructions for VIB 3.430 ... VIB 3.432**

dimensions in mm

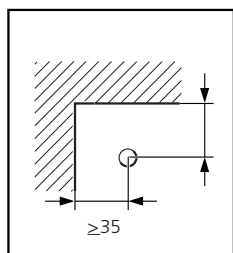

Allow clearance for transducer

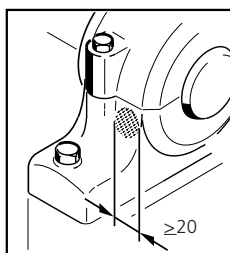

Mounting surface: flat & roughened

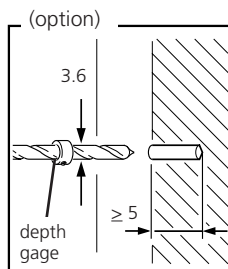

(Option: bore hole for centering pin)

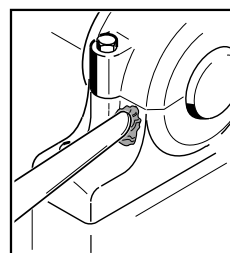

Apply compound to both surfaces

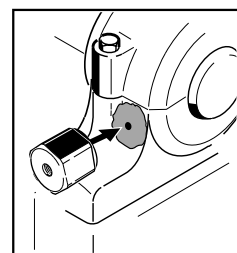

Press & turn adapter into surface

**Height**

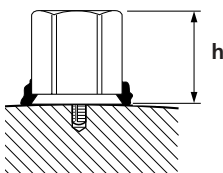

Adapter Order no.	Height h in mm
VIB 3.418	6
VIB 3.433	8
VIB 3.430	16
VIB 3.431 / VIB 3.432	21



## Magnetic holders for accelerometers

VIB 3.420 : Magnetic holder for curved surfaces, M5 internal thread

VIB 3.422 : Magnetic holder for flat surfaces, M5 internal thread

VIB 3.423 : Magnetic holder for flat surfaces, ¼-28 UNF thread

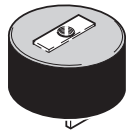

VIB 3.420



VIB 3.422

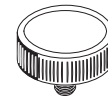

VIB 3.423

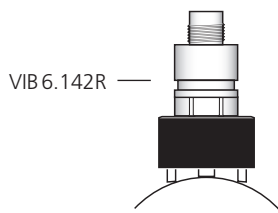

VIB 6.142R

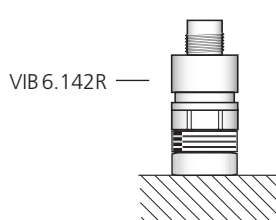

VIB 6.142R

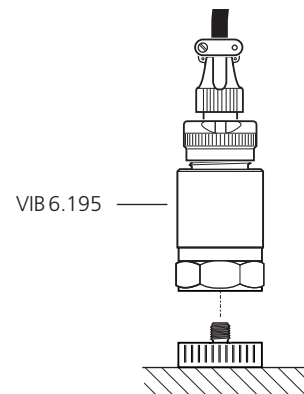

VIB 6.195

### Application

During mobile measurements magnetic holders can be used to attach accelerometers easily and securely at measurement locations with a ferromagnetic base.

The magnetic adapter VIB 3.420 offers secure hold on both curved and flat surfaces.

### Notes

Shock pulse measurements (of anti-friction bearings and pump cavitation) may not be performed using magnetic holders.

During transport / storage a steel washer as a short-circuit rail is mounted on the pole pieces.

The safety data sheet is available upon request (info@pruftechnik.com) or in the Internet (www.pruftechnik.com).

### Technical data

PARAMETER		VIB 3.420	VIB 3.422	VIB 3.423
General	Housing material	Plastic PA6, Poles made of steel	Steel	Steel
	Magnet	NdFeB (Neodymium-Iron-Boron)		
	Temperature range (for PA6)	-40°C ... +120°C	--	
	Connection to accelerometer	M5		¼-28 UNF
	Weight, total	70 g	27 g	41 g
	Weight, magnet	28 g	5 g	7 g
	Diameter	34 mm	20 mm	25 mm
	Height	23 mm	11 mm	10 mm

C

## Extension posts for industrial accelerometers

1

VIB 8.586 : Extension post for industrial accelerometer, M8 x 55 mm

VIB 8.587 : Extension post for industrial accelerometer, M8 x 95 mm

VIB 8.588 : Extension post for industrial accelerometer, M8 x 170 mm

2

VIB 8.589 : Extension post for industrial accelerometer, M8 x 35 mm

VIB 8.590 : Extension post for industrial accelerometer, UNC 5/16 x 2 1/8"

VIB 8.591 : Extension post for industrial accelerometer, UNC 3/8 x 3 3/4"

3

VIB 8.592 : Extension post for industrial accelerometer, UNC 1/2 x 6 5/8"

VIB 6.122R

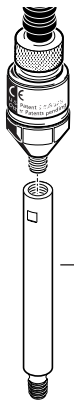

Ø = 12 mm

VIB 8.589

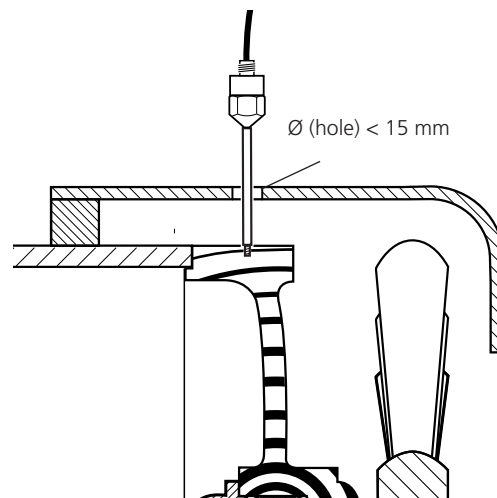

4

5

6

A

### Application

As its name implies, the extension post provides an extra-long shaft to allow measurement in locations where the stem of the industrial accelerometer does not fit directly at the measurement surface. This stud is available in various lengths with an M8 or UNC thread at its bottom.

### Material

Stainless steel, VA1.4305

### Note

The longest extension posts (170 mm and 6 5/8") should be used only for bearing condition readings and not for general vibration measurements.

### Installation accessories

VIB 8.693 M8 screw tap  
 VIB 8.696 UNC 5/16 screw tap  
 VIB 8.694 90° countersink bit

### Mounting instructions

dimensions in mm

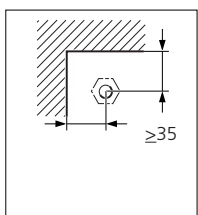

Select position

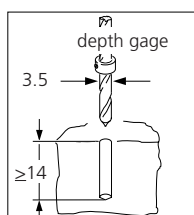

Bore pilot hole

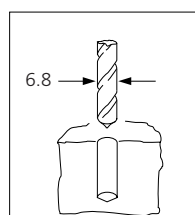

Bore out hole

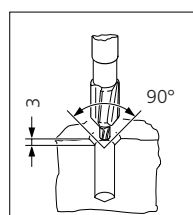

90° countersink

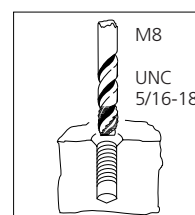

Tap thread

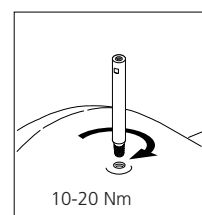

Mount post

## VIBCODE measurement studs

VIB 8.679 SET : VIBCODE measurement stud, M8, high quality stainless steel (VA1.4571), 1 pc.

VIB 8.680 SET : VIBCODE measurement stud, M8, stainless steel (VA1.4305), 1 pc.

VIB 8.680 A25 : VIBCODE measurement studs, M8, stainless steel (VA1.4305), 25 pcs.

VIB 8.689 SET : VIBCODE measurement stud, UNC 5/16, high quality stainless steel (VA1.4571), 1 pc.

VIB 8.689 A25 : VIBCODE measurement studs, UNC 5/16, high quality stainless steel (VA1.4571), 25 pcs.

VIB 8.690 SET : VIBCODE measurement stud, UNC 5/16, stainless steel (VA1.4305), 1 pc.

VIB 8.690 A25 : VIBCODE measurement studs, UNC 5/16, stainless steel (VA1.4305), 25 pcs.

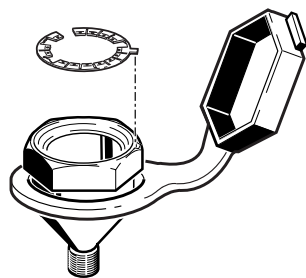

Distinctive feature

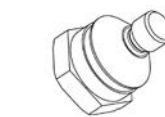

VIB 8.679 SET



VIB 8.690 SET



VIB 8.680 SET



VIB 8.689 SET

### Description

These VIBCODE measurement studs are the standard measurement locations used with the VIBCODE transducer. Each stud is coded by breaking off specific tabs from the plastic ring using a ring encoding tool according to the unique pattern generated by OMNITREND for each measurement location.

The resulting pattern is read by the VIBCODE probe to identify the measurement location (and from it, its required measurement tasks) reliably and automatically.

Studs made out of high quality stainless steel (composite VA 1.4571) are particularly suited for applications in exceptionally harsh chemical environments.

### Installation accessories

- VIB 8.693 M8 screw tap
- VIB 8.696 UNC 5/16 screw tap
- VIB 8.694 90° countersink bit

### Accessories

- VIB 8.563 A25 VIBCODE code rings, 25 pcs.
- VIB 8.692 VIBCODE encoding tool
- VIB 8.566 Protective cap
- VIB 8.568/.. Color coding for protective cap, 25 pcs.

### Scope of delivery for one VIBCODE meas. stud

1x stainless steel bolt, 1x code ring, 1x protective cap.

### Mounting instructions

dimensions in mm

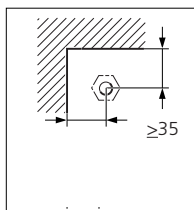

Select position

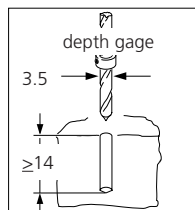

Bore pilot hole

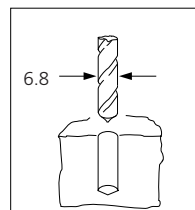

Bore out hole

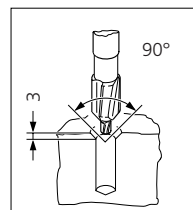

90° countersink

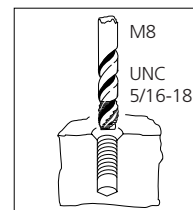

Tap thread

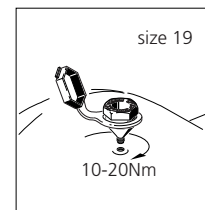

Mount stud

### Height

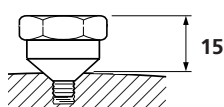

C

## VIBCODE measurement studs with extension post

1

VIB 8.576 : VIBCODE measurement stud with extension post, M8 x 55 mm

VIB 8.577 : VIBCODE measurement stud with extension post, M8 x 95 mm

VIB 8.578 : VIBCODE measurement stud with extension post, M8 x 170 mm

2

VIB 8.580 : VIBCODE measurement stud with extension post, UNC 5/16 x 2 1/8"

VIB 8.581 : VIBCODE measurement stud with extension post, UNC 3/8 x 3 3/4"

VIB 8.582 : VIBCODE measurement stud with extension post, UNC 3/8 x 6 5/8"

3

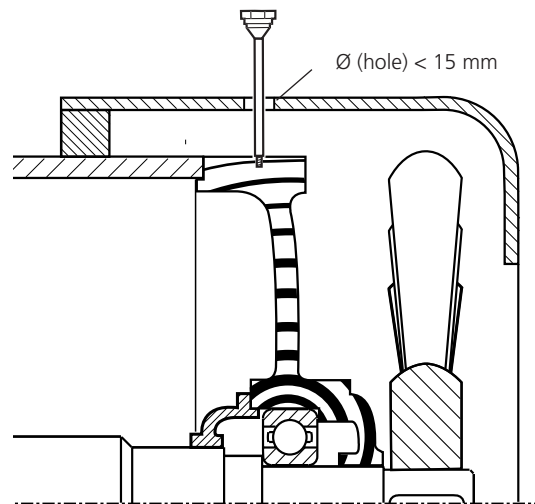
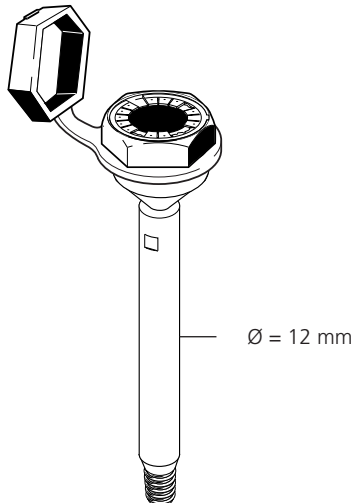

4

5

6

A

### Application

As its name implies, these studs feature an extra-long shaft to allow measurement in locations where the VIBCODE transducer does not fit directly at the measurement surface. The studs are available in various lengths with an M8 or UNC 5/16 thread at its bottom.

### Note

The longest extension (170 mm and 6 5/8") may be used only for taking shock pulse readings and not for vibration measurement!

### Material

Stainless steel, VA1.4305

### Installation accessories

- VIB 8.693 M8 screw tap
- VIB 8.696 UNC 5/16 screw tap
- VIB 8.694 90° countersink bit

### Accessories

- VIB 8.563 A25 VIBCODE code rings, 25 pcs.
- VIB 8.692 VIBCODE encoding tool
- VIB 8.566 Protective cap
- VIB 8.568/.. Color coding for protective cap, 25 pcs.

### Scope of delivery for one VIBCODE meas. stud

1x stainless steel bolt, 1x code ring, 1x protective cap, 1x extension post.

### Mounting instructions

dimensions in mm

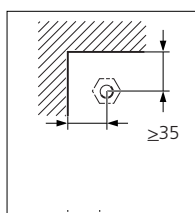

Select position

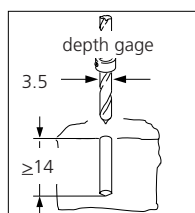

Bore pilot hole

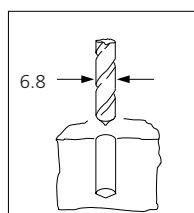

Bore out hole

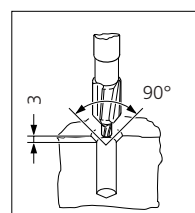

90° countersink

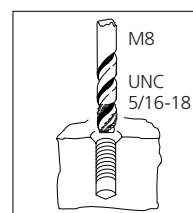

Tap thread

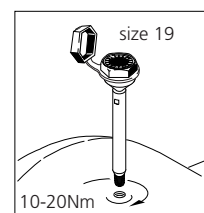

Mount post

## VIBCODE measurement studs with locking nut

VIB 8.571 :	VIBCODE measurement stud with locking nut, M8
VIB 8.572 :	VIBCODE measurement stud with locking nut, M10
VIB 8.573 :	VIBCODE measurement stud with locking nut, M12
VIB 8.594 :	VIBCODE measurement stud with locking nut, UNC 5/16
VIB 8.595 :	VIBCODE measurement stud with locking nut, UNC 3/8 - 16
VIB 8.596 :	VIBCODE measurement stud with locking nut, UNC 1/2 -13

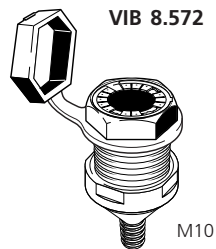

Bolt does not touch casing!

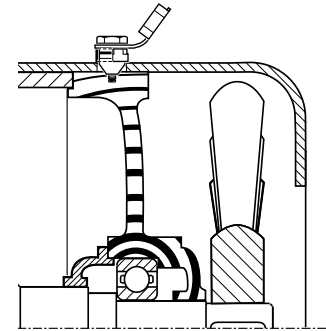
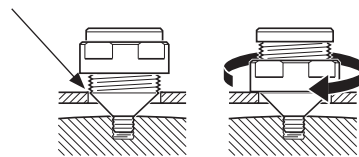

### Application

The VIBCODE measurement studs with locking nut are ideal for situations such as motor housings where there is little clearance between the actual mounting location (e.g. the bearing housing) and the machine housing. This arrangement can even be used to replace existing housing screws. Once the stud is torqued into the threaded hole prepared for measurement, the counter nut can be tightened against the machine housing.

To ensure optimum signal transmission, the cone of the bolt may only touch the measuring point (e.g. the bearing housing), but not the metal casing.

### Material

Stainless steel, VA1.4305

### Mounting instructions

dimensions in mm

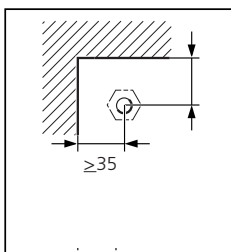

Ensure sufficient clearance

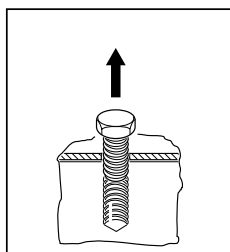

Remove bolt and housing cowling

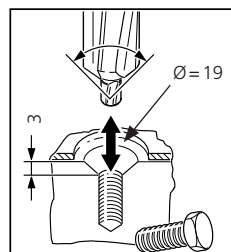

Countersink hole, bore cowling

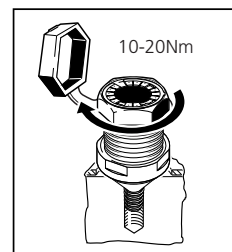

Mount adapter

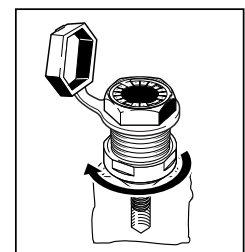

Fasten locking nut

### Height

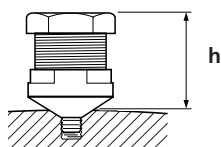

Height h in mm	Adapter Order no.
28	VIB 8.571 / VIB 8.594
27	VIB 8.572 / VIB 8.595
26	VIB 8.573 / VIB 8.596

### Installation accessories

VIB 8.693	M8 screw tap
VIB 8.696	UNC 5/16 screw tap
VIB 8.694	90° countersink bit

### Accessories

VIB 8.563 A25	VIBCODE code rings, 25 pcs.
VIB 8.692	VIBCODE encoding tool
VIB 8.566	Protective cap
VIB 8.568/..	Color coding for protective cap, 25 pcs.

### Scope of delivery for one VIBCODE meas. stud

1x stainless steel bolt, 1x code ring, 1x protective cap, 1x locking nut.

## C VIBCODE measurement studs for adhesive mounting

1

VIB 8.685 SET : VIBCODE measurement stud for adhesive mounting, 1 pc.

VIB 8.685 A25 : VIBCODE measurement stud for adhesive mounting, 25 pcs.

2

3

4

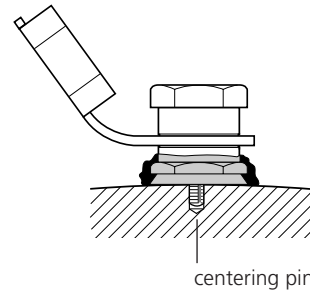
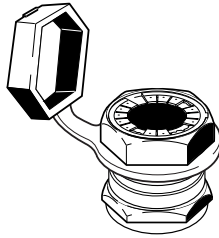

5

### Application

These VIBCODE measurement studs are ideal when only adhesive mounting is possible.

6

### Mounting notes

A removable self-threading centering pin may be used if desired to hold the stud in place while the adhesive cures to final hardness.

A

### Material

Stainless steel, VA1.4305

### Installation material for adhesive mount:

2-component adhesive (e.g. WEICON HB 300).

### Accessories

VIB 8.563 A25 VIBCODE code rings, 25 pcs.

VIB 8.692 VIBCODE encoding tool

VIB 8.566 Protective cap

VIB 8.568/.. Color coding for protective cap, 25 pcs.

### Scope of delivery for one VIBCODE meas. stud

1x stainless steel bolt, 1x code ring, 1x protective cap.

## Mounting instructions

dimensions in mm

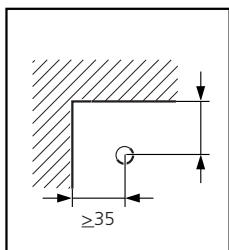

Allow clearance  
for transducer

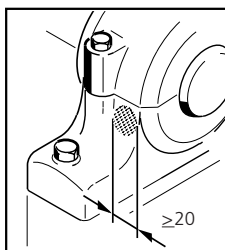

Mounting surface:  
flat & roughened

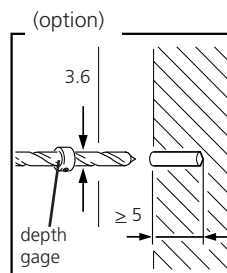

(Option: bore hole  
for centering pin)

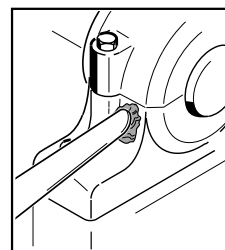

Apply compound  
to both surfaces

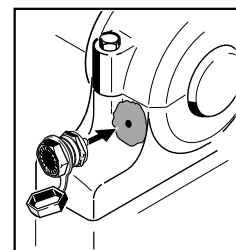

Press & turn adapter  
into surface

### Height

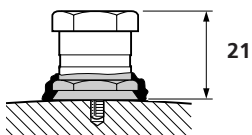

## Accessories for VIBCODE measurement studs

VIB 8.563 A25 :	VIBCODE code ring, 25 pcs.
VIB 8.566 :	Protective cap for VIBCODE stud
VIB 8.568/B :	Color coding for protective cap, black, 25 pcs.
VIB 8.568/GN :	Color coding for protective cap, green, 25 pcs.
VIB 8.568/GR :	Color coding for protective cap, gray, 25 pcs.
VIB 8.568/W :	Color coding for protective cap, white, 25 pcs.
VIB 8.568/Y :	Color coding for protective cap, yellow, 25 pcs.
VIB 8.692 :	VIBCODE encoding tool

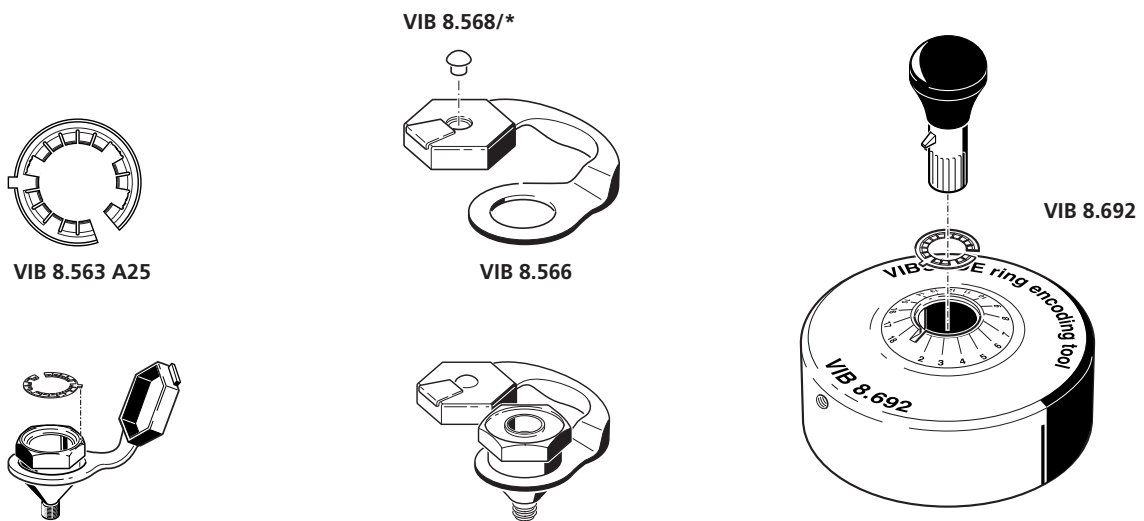

### Description

The protective cap VIB 8.566 protects the measurement surfaces and code ring from damage by aggressive industrial materials. Each VIBCODE measurement location can be individually color-coded for easy recognition during route-based data collection.

Example:

VIBCODE locations to be measured daily can be marked with black color coding, while green color coding can be used to mark VIBCODE locations that require only weekly measurement.

The plastic tabs of the code ring VIB 8.563 may easily be removed using the VIBCODE encoding tool VIB 8.692 as illustrated above. The ring then fits into the VIBCODE stud; a tab on the outside of the ring provides positive orientation.

Encoding the code ring:

1. Insert code ring
2. Insert plunger
3. Set code number (issued by OMNITREND software)
4. Slowly press down plunger

### Technical data

PARAMETER		VIB 8.566	VIB 8.563 A25
General	Material	Desmopan®	Hostaform®
	Temperature range	-30°C ... +100°C	-40°C ... +130°C
	Resistance	oil, coolant	

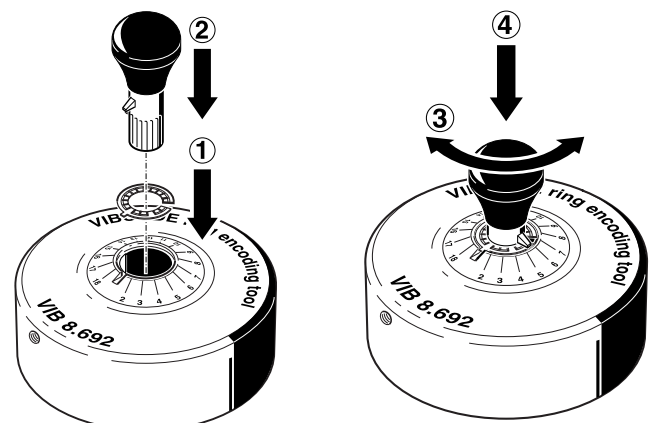

C

## Stand and accessories for laser trigger / laser RPM sensor

1

VIB 6.632 : Stand for laser trigger / laser RPM sensor

VIB 3.306 : Reflective tape

2

3

4

5

6



VIB 6.632

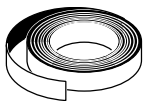

VIB 3.306

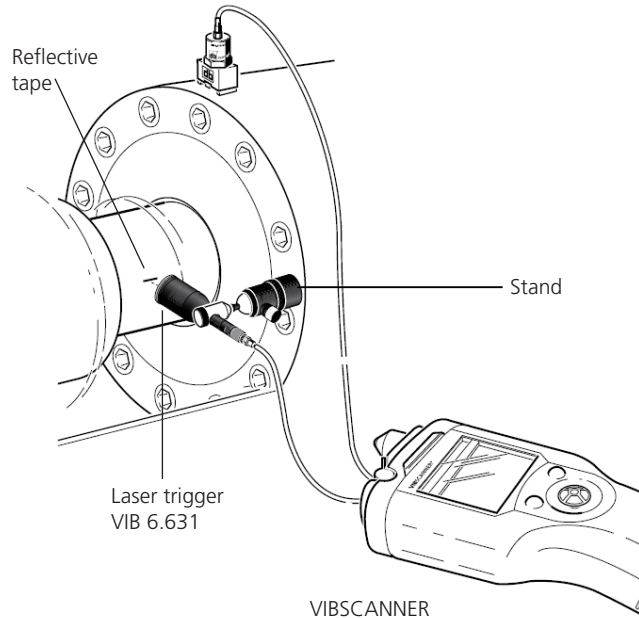

A

### Description

This compact and stable stand can be used to quickly and securely mount the laser trigger sensor on any machine.

The laser trigger sensor is fixed in a bracket on the stand and the stand is fastened to the machine with a magnetic holder VIB 3.420. To adjust the sensor, the ball joint can be fixed in virtually any position.

The reflective tape VIB 3.306 is used as a measurement mark on the shaft.

### Notes

During transport / storage a steel washer as a short-circuit rail is mounted on the pole pieces.

The safety data sheet is available upon request (info@pruftechnik.com) or in the Internet (www.pruftechnik.com).

### Accessories

VIB 3.420 Magnetic holder, spare part

### Technical data

PARAMETER		VIB 6.632
General	Weight	approx. 230 g
	Height	max. 116 mm
	Mounting	magnetic

PARAMETER		VIB 3.306
General	Material	SL7610
	Width	10 mm
	Length	approx. 4.5 m on roll

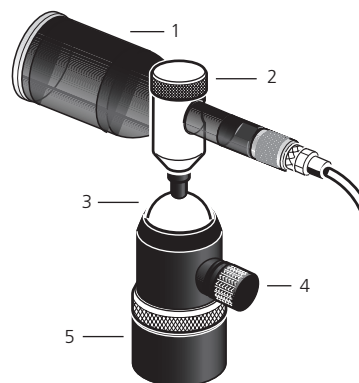

1. Laser trigger sensor
2. Sensor carrier with locking screw
3. Ball joint
4. Locking screw for ball joint
5. Magnetic holder, VIB 3.420



## Measurement studs for accelerometer type VIB 8.666

VIB 32000 :	Measurement stud for accelerometer type VIB 8.666, M8x24, nickel-plated
VIB 32010 :	Measurement stud for accelerometer type VIB 8.666, M8x24, stainless steel
VIB 32200 :	Measurement stud for accelerometer type VIB 8.666, M8x113, nickel-plated
VIB 32210 :	Measurement stud for accelerometer type VIB 8.666, M8x113, stainless steel
VIB 32310 :	Measurement stud for accelerometer type VIB 8.666, M8x202, stainless steel
VIB 32410 :	Measurement stud for accelerometer type VIB 8.666, M8x291, stainless steel
VIB 33000 A25 :	Measurement stud for accelerometer type VIB 8.666, adhesive mount, stainless steel, 25 pcs.
VIB 81025 :	Protective cap for measurement stud, black

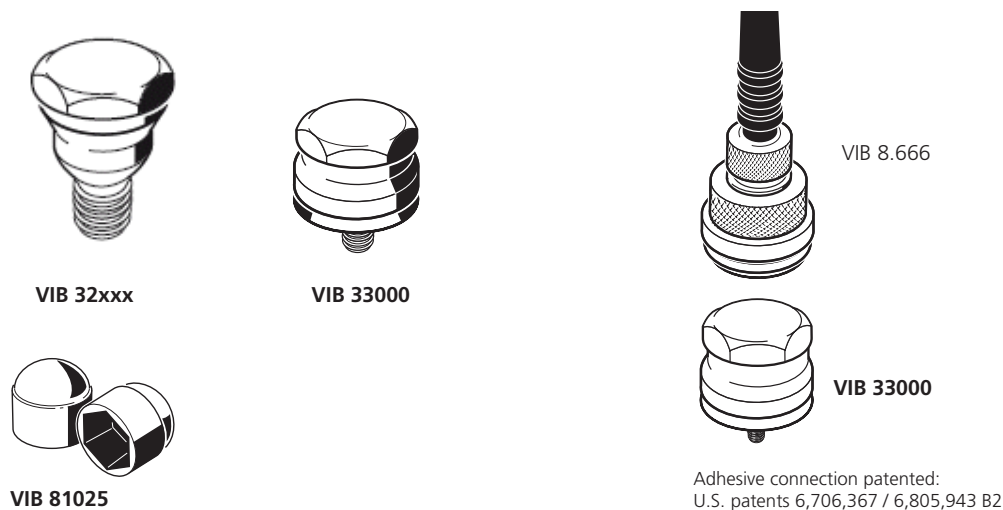

### Application

These measurement studs are used to mount the accelerometer type VIB 8.666 on the machine. They represent a defined measurement location and are very robust and resilient.

The stud VIB 33000 is used when only adhesive mounting is possible. A removable self-threading centering pin may be used if desired to hold the stud in place while the adhesive cures to final hardness.

The measurement studs VIB 32xxx are the standard studs for the accelerometer type VIB 8.666.

Studs made out of high quality stainless steel (composite VA 1.4305) are particularly suited for applications in exceptionally harsh chemical environments.

Installation material for adhesive mount:  
2-component adhesive (e.g. WEICON HB 300).

### Accessories

VIB 81025 Protective cap for measurement stud

### Installation accessories

VIB 8.693 M8 screw tap  
VIB 8.694 90° countersink bit

### Technical data

PARAMETER		VIB 32000	VIB 32200	VIB 32010	VIB 32210	VIB 32310	VIB 32410	VIB 33000
General	Material	9 SMn28K (W.Nr. 1.0715.07), nickel-plated			Stainless steel (VA 1.4305)			
	Height X	24 mm	113 mm	24 mm	113 mm	202 mm	294 mm	14 mm
	Dimensions	see figure below						

PARAMETER		VIB 81025
General	Material	LDPE
	Operating temp.	< 70°C
	Height	19 mm
	Wrench size	17

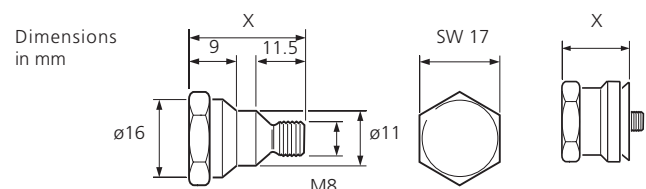

C

**VIB 3.450: Probe tip for mobile industrial accelerometer type VIB 6.14x**

1

2

3

4

5

6

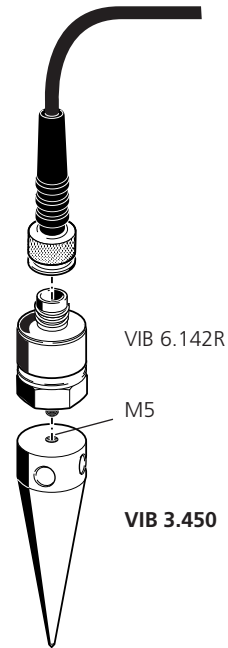
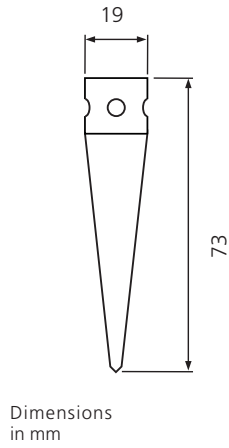

A

**Application**

The accelerometer type VIB 6.14x can be used as a mobile hand-held probe through use of a contact tip.

**Technical data**

PARAMETER		VIB 3.450
General	Material	Aluminium
	Weight	30 g
	Dimensions	s. figure

## Tools for the installation of accelerometers and for the preparation of meas. locations

VIB 8.610 : PRÜFTECHNIK countersink bit

VIB 8.693 : M8 thread tap

VIB 8.694 : 90° counter sink bit

VIB 8.696 : UNC5/16 thread tap

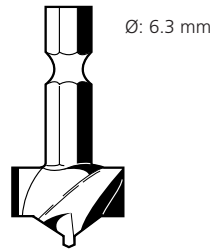

VIB 8.610



VIB 8.693  
VIB 8.696



VIB 8.694

### Application

The PRÜFTECHNIK countersink bit VIB 8.610 should always be used to prepare the location for VIBROTIP's, VIBSCANNER's or TIPECTOR's vibration and shock pulse sensor. The countersink produces a hole smaller than the built-in sensor. A ring-shaped contact area is thereby created between the sensor and the measurement surface, providing optimal signal transmission. And as an important side benefit for reliable comparison between successive readings: this clearly marks the measurement location so that readings are always taken in the exact same spot.

The bit has a hexagonal shaft compatible with a standard battery-operated screwdriver. This is recommended in preference to an electric drill as only a relatively shallow countersunk hole is needed.

### Notes

on how to prepare the measurement location:

1. Clean and then mark the exact desired measurement location.
2. Drill with a battery operated screwdriver until the rim of the countersink is level with the measurement surface (see below).
3. Blow any shavings out of the hole with compressed air (using a thin hose or tube).

Make sure that the hole is completely free of metal particles, which otherwise could contact the sensor and interfere with proper signal transmission. Place the accelerometer as perpendicular to the surface as possible. Otherwise, the measuring direction does not correspond to the ISO standards!

The thread taps VIB 8.693 and VIB 8.696 and the 90° counter sink bit VIB 8.694 are used to prepare measurement locations for industrial accelerometer mounting.

In addition, drill bits of sizes 3.5 mm (1/8") (with depth gage) and 6.8 mm (1/4") are required.

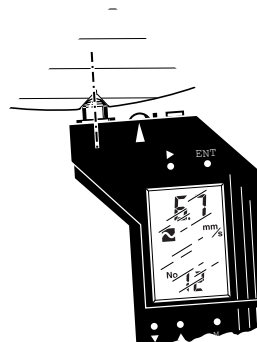
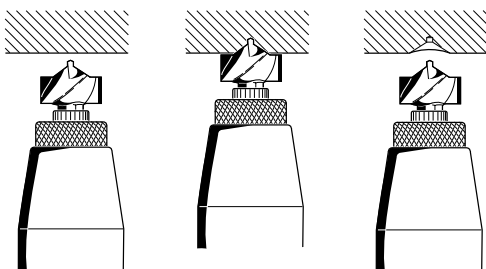

C

1

2

**3**

4

5

6

A

# Chapter 4

## Cables, interfaces and accessories for permanent installation

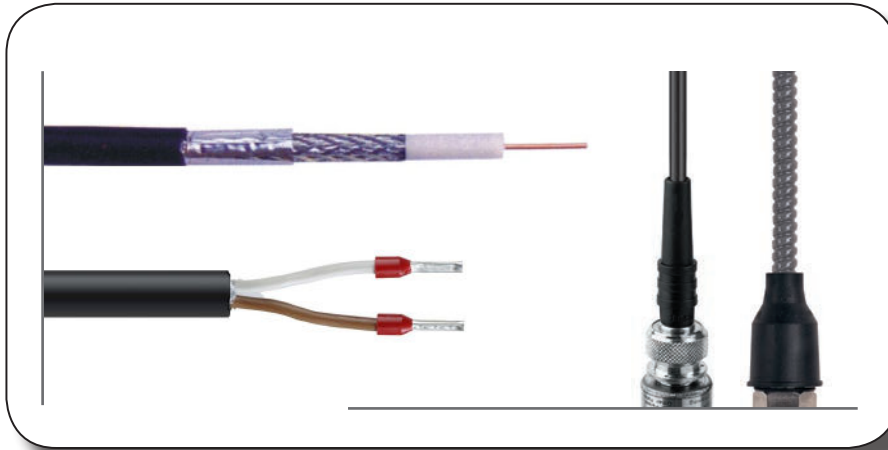

C

## Contents: Cables, interfaces and accessories for permanent installation

1

2

3

4

5

6

A

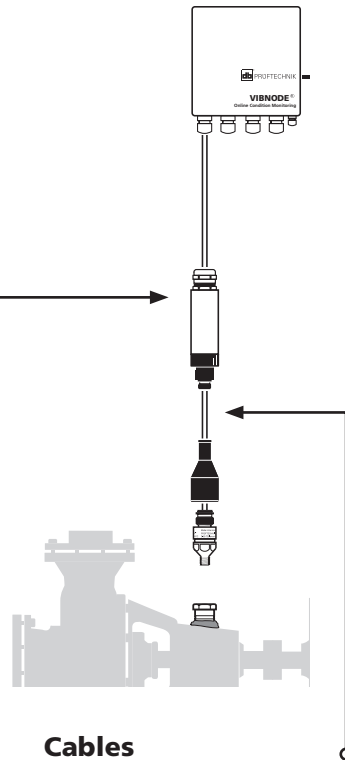

## Interfaces

Order no.	Description	Page
0 2088 0009 0 2088 0010 VIB 3.550	Safety barrier for ICP-type accelerometers Transmitter supply unit VIBROTECTOR EX Limiting device, CLD-type accelerometers	127
VIB 7.560	VIBROWEB connection box	135
VIB 6.770/9 VIB 6.770/13 VIB 6.776	Junction box (aluminium) for the extension of a sensor cable -, coaxial - coaxial -, coaxial - triaxial -, twisted-pair/ 2-pin	129
VIB 6.775/9 VIB 6.775/13	Junction box for the extension of two sensor cables -, coaxial - coaxial -, coaxial - triaxial	131
VIB 8.306 VIB 8.306 S VIB 8.306 V	VIBRONET field multiplexer, 9-channel, -, w/ threaded fitting M12 -, w/ threaded fitting M20 -, stainless steel housing, M20	132
VIB 8.306 EX	VIBRONET field multiplexer, 9-channel, -, intrinsically safe, aluminium housing	133
VIB 8.310 VIB 8.310 EX VIB 8.312 VIB 8.313 VIB 8.313 EX VIB 8.314 EX	Connection modules for VIBRONET field multiplexer Temperature module -, intrinsically safe Process parameters module (U / I) RPM module -, intrinsically safe Vibration module, intrinsically safe	134

## Cables

Order no.	Description	Page
VIB 3.570-L	Pre-assembled cable for intrinsically safe VIBROTECTOR and ICP-type accelerometers	122
VIB 3.575-10 VIB 3.575-20	Sensor cable for triaxial accelerometers (VIB 6.215 / VIB 6.216), 10 / 20 meters	123
VIB 5.740-X VIB 5.741-X	Sensor cable for VIBROTECTOR & CLD-/ICP-type accelerometers -, silicone sheath, straight connector -, silicone sheath, angled connector	120
VIB 5.745-L VIB 5.746-L	Sensor cable for VIBROTECTOR & CLD-/ICP-type accelerometers -, PUR sheath, angled connector -, PUR sheath, straight connector	121
VIB 5.771	Pre-assembled VIBREX cable	124
VIB 6.420-L VIB 6.426-L	Pre-assembled WEARSCANNER cables... for power supply & data transmission for switching output	126
VIB 7.115-6 VIB 7.115-12	Pre-assembled VIBNODE cables -, Twisted-pair (TP), 6 m -, Twisted-pair (TP), 12 m	125
VIB 90006 VIB 90007 VIB 90008 VIB 90009 VIB 90093	Coaxial cable RG58 -, for hazardous areas (blue) -, oil-resistant, max. 150°C -, for low ambient temperatures > - 40°C -, halogen free & highly flame retardant -, oil-resistant, max. 125°C	112
VIB 90030	Industrial Ethernet cable, CAT5	119
VIB 90061 VIB 90065	Twisted-pair sensor cable, PUR sheath Sensor cable, silicone and cable armor	117
VIB 90070	Multi-core twisted-pair sensor cable	118
VIB 90080 VIB 90180	Standard triaxial cable Standard triaxial cable, armored version	113
VIB 309007-6 VIB 309007-10 VIB 309007-15 VIB 309007-20	Pre-assembled VIBNODE cables -, coaxial, 6 m -, coaxial, 10 m -, coaxial, 15 m -, coaxial, 20 m	125

## Contents: Cables, interfaces and accessories for permanent installation

### Accessories for cable installation

Order no.	Description	Page
VIB 6.700 VIB 6.701 VIB 6.710 VIB 6.711 VIB 6.720 VIB 6.721 VIB 6.722	Dust caps for accelerometers VIB 6.1xx -, straight -, straight and oil-resistant -, angled -, angled and oil-resistant Clamp for dust cap, cable end -, sensor end Dust cap sleeve	141
VIB 6.725-100	Shield connector set for coaxial and twisted-pair cables	116
VIB 6.730	Protective sheath for coaxial cables	115
VIB 6.760 VIB 6.761	IP 68 option for accelerometer VIB 6.1xx -, short version	144
VIB 7.580..3	Open ring spanners size 14x17 / 19x22 / 24x27 / 24x25	136
VIB 7.590..3 VIB 7.595	Metric cable fittings M16 / M20 / M25 / M12 Shield clamp SK8	137
VIB 8.718	Cable clamp for prot. sheath VIB 6.730	115
VIB 8.745	Installation checker	143
VIB 81015	Protective sleeve for cable type RG 174	26
VIB 81026 VIB 81052 VIB 81053 VIB 81054	Crimping tool for coaxial cables Cutting tool for coaxial cables Cable stripper for triaxial cables Replacement blade for cable stripper	114
VIB 81060	Screw driver 2.5 x 35	137
VIB 91000	Chassis connector, TNC socket to crimp	140
VIB 91001 VIB 91002 VIB 91009 VIB 93022	TNC plug to threaded fitting, angled TNC plug to TNC socket, angled BNC plug to crimp contact, angled TNC plug to crimp contact, straight	138
VIB 93025	TNC plug to crimp contact, RG174 cable	26
VIB 93031 VIB 93033	TNC plug to threaded fitting, straight TNC socket to TNC socket, straight	138
VIB 93035 VIB 93036 F VIB 93036 S	Dust cap for TNC socket Bulkhead connector w/ fastening flange -, single hole screw version	140
VIB 93047 VIB 93055	TNC socket to crimp contact, straight TNC plug to BNC plug, straight	138
VIB 93056	Bulkhead connector, flange, BNC- TNC	140
VIB 93060	BNC plug to crimp contact, straight	138
VIB 93061	Dust cap for BNC socket	140
VIB 93062 VIB 93067 VIB 93077	TNC socket to BNCplug, straight TNC plug to BNC socket, straight TNC plug to crimp contact, angled	138
VIB 93090	Chassis connector, BNC socket to crimp	140
VIB 94010 VIB 94011	Plug-in connector, 2-pin, straight Plug-in connector, 2-pin, angled	139

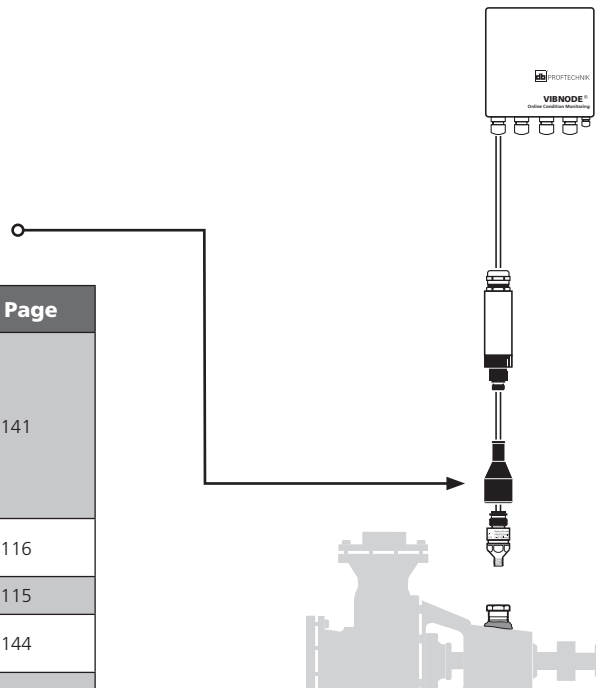

## C Coaxial cables for permanent installation

1	VIB 90006 : Coaxial cable for hazardous areas, PVC cable sheath, blue
2	VIB 90007 : Coaxial cable for high ambient temperatures (< 150°C), oil-resistant
3	VIB 90008 : Coaxial cable for low ambient temperatures (> - 40°C)
4	VIB 90009 : Coaxial cable, halogen free and highly flame retardant
5	VIB 90093 : Coaxial cable for high ambient temperatures (< 125°C), oil-resistant

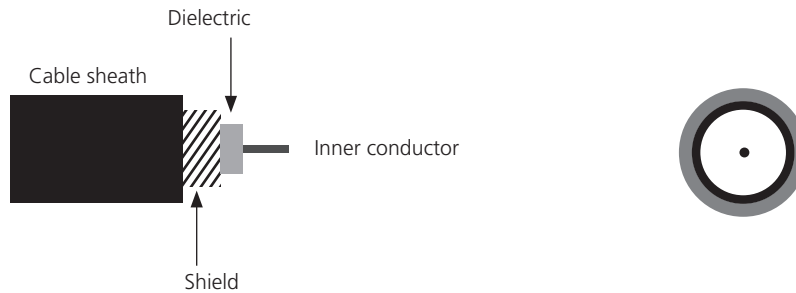

### Application

Coaxial cables (RG 58) are used for the transmission of high frequency measurement signals. For special applications the coaxial cables are available in different versions.

### Accessories

VIB 6.730	Protective sheath for coaxial cables
VIB 8.718	Cable clamp for protective sheath
VIB 81052	Cutting tool for coaxial cables

### Order information

Add the required cable length to the order number.

Example: Coaxial cable, 250 meters  
Order no.: VIB 90008-250

Bundle: Ring up to 100 meters,  
Roll up to 500 meters

### Technical data

PARAMETER		VIB 90007	VIB 90006	VIB 90008	VIB 90009	VIB 90093
Measurement	Type	RG 142 B/U	RG 58			
	Char. impedance	50 Ohm				
	Capacitance	95 nF/km	101 nF/km	101 nF/km	101 nF/km	105 nF/km
	Attenuation <sup>1</sup>	28 dB/100m	38 dB/100m	32 dB/100m	38 dB/100m	46 dB/100m
Cable design	Inner conductor	Steel, Cu + Ag	Cu strand, tinned			
	Dielectric	PTFE	PE white	MDPE white	PEX (PE cross-linked)	Rayolin™
	Shield	2xCu braid, Ag	Cu braid, tinned			
	Sheath	FEP, brown	PVC, blue	MDPE, black	RADOX GKW S, black	Thermorad® S, black
Mechanical	Temperature range	-65°C ... + 165°C	-25°C ... + 85°C	-40°C ... + 80°C	-25°C ... + 105°C	-50°C ... + 125°C
	Bending radius	50 mm				
	External diameter	5 mm				
	Weight	6.4 kg / 100 m	3.7 kg / 100 m	4 kg / 100 m	4 kg / 100 m	3.5 kg / 100 m
	Special features	oil resistant, double screened	hazardous area (blue sheath)	halogen free IEC 60708	halogen free, highly flame retardant	oil resistant

<sup>1</sup> at 400 MHz / 25°C / sea level



## Triaxial cables for permanent installation

VIB 90080 : Standard triaxial cable

VIB 90180 : Standard triaxial cable, armored version

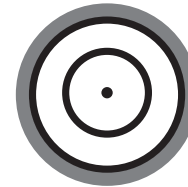
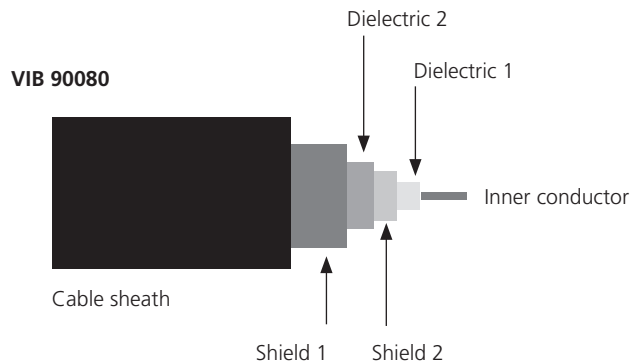

### Application

Triaxial cables are used for the transmission of high frequency measurement signals. The cable has two screening conductors and a inner conductor. Thus, triaxial cables are particularly suitable for use in industrial environments that are subject to electromagnetic fields.

The armored version has an additional jacket of steel for increased mechanical protection (against vermin, mouse bites, ...).

### Note

The cable sheath of the armored version VIB 90180 does not contain any silicone or talcum and, as a result, can also be used in the automotive industry (e.g. paint shops).

### Accessories

VIB 81053 Cable stripper for triaxial cables

VIB 81054 Replacement blade for cable stripper

### Order information

Add the required cable length to the order number.

Example: Standard triaxial cable, 250 meters  
Order no.: VIB 90080-250

Bundle: Ring up to 100 meters,  
Roll up to 500 meters (VIB 90080) or  
250 meters (VIB 90180)

### Technical data

PARAMETER		VIB 90080	VIB 90180
Electrical	Type	RG 58	
	Char. impedance	50 Ohm	
	Capacitance	approx. 105 nF/km (1kHz)	-
	Attenuation	34 dB/100m (300 MHz, 20°C)	-
Cable design	Inner conductor	Cu braid, tinned	
	Dielectric	PE	
	Shield	Cu strand, tinned	
	Sheath	PUR	PUR; armouring: steel braid, tinned
Mechanical	Temperature range	-40°C ... + 80°C	-10°C ... + 80°C
	Bending radius	50 mm	60 mm
	External diameter	10 mm	14 mm*
	Weight	12.6 kg / 100 m	-
	Special features	silicone free, UV-stabilized, flame retardant (IEC 60332-1-2), RoHS compliant (2002/95/EG)	silicone free, talcum free, UV-stabilized

\* not suitable for standard threaded fittings (M20) of the VIBRONET 9-channel field multiplexers (VIB 8.306).

C

## Installation tools for coaxial, triaxial and twisted-pair cables

1

VIB 81026 : Crimping tool for coaxial cables

VIB 81052 : Cutting tool for coaxial cables

VIB 81053 : Cable stripper for triaxial cables

2

VIB 81054 : Replacement blade for cable stripper VIB 81053

3

4

5

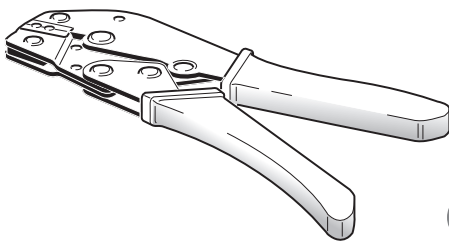
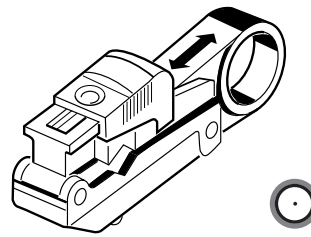
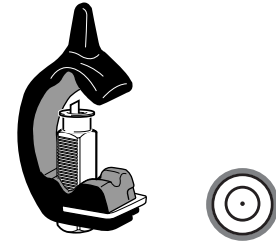
Crimping tool for coaxial cables  
VIB 81026Cutting tool for coaxial cables  
VIB 81052Cable stripper for triaxial cables  
VIB 81053

6

### Application

The crimping tool is a special pliers and is used to crimp coaxial cables (RG 58 / RG 59).

The VIB 81052 cutting tool cleanly strips the ends of coaxial cables for proper connection.

The cable stripper VIB 81053 is ideal for stripping wires with a diameter of 6 mm to 28 mm.

A

### Instructions for crimping (BNC/ TNC)

- Slide sleeve A onto the cable.
  - Strip the insulation of the cable as shown in diagram.
- CAUTION!**  
Do not damage the shielding, dielectric or inner conductor!
- Push signal pin B over the cable inner conductor up to the dielectric and crimp it.
  - Spread the shielding slightly apart and insert the cable into the connector housing C. The shielding must lie over the crimping throat.
  - Push sleeve A over the shielding and crimp as close as possible to housing C.

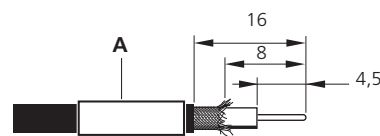
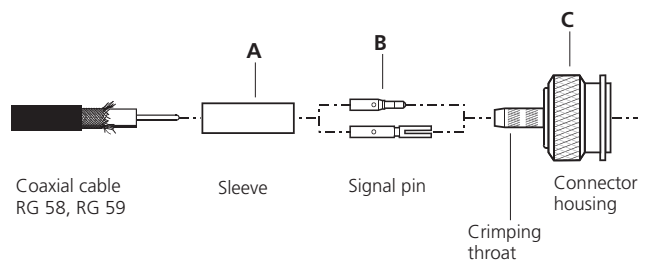

Dimensions in mm

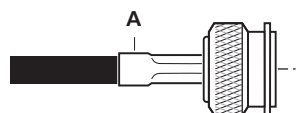
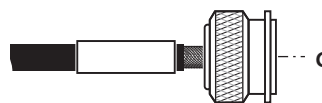

## VIB 6.730 : Protective sheath for standard coaxial cables

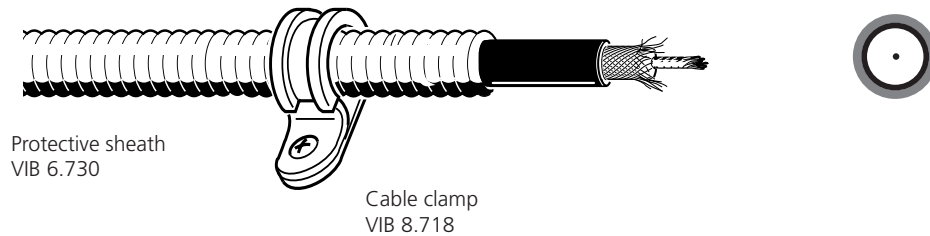

### Application

A protective sheath made of plastic protects the standard coaxial cables against mechanical damage. Cable clamps should be used for strain relief.

### Accessories

VIB 8.718 Cable clamp for protective sheath

### Order information

Add the required cable length to the order number.

Example: Protective sheath, 250 meters  
Order no.: VIB 6.730-250

### Technical data

PARAMETER		VIB 6.730
Cable design	Material	Polyamide 6, color: black
	Nominal diameter	6.5 mm
	External diameter	10 mm
	Bending radius	13 mm
Environment	Temperature range	-40°C ... + 115°C
	Chemical resistance	Oil, petrol
	Environmental influences	UV and weather resistant
	Special features	flame-retardant, self-extinguishing in acc. with UL94 V0, silicone, cadmium, halogen free

C

## VIB 6.725-100 : Shield connector set for coaxial and twisted-pair cables

1

2

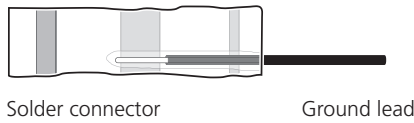

3

4

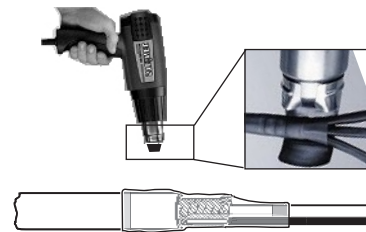
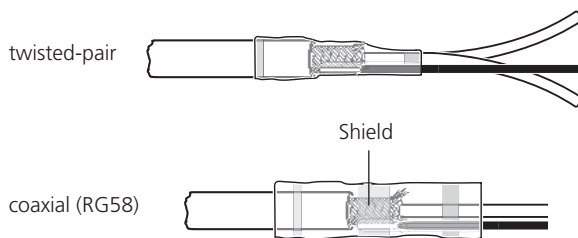

5

6

A

### Application

The soldering bush simplifies the task of connecting the shield of the coaxial and twisted pair cables. These cable types are used as sensor lines in the PRÜFTECHNIK online condition monitoring systems. The method eliminates the time-consuming preparation of a shielding braid.

### Installation

The soldering bush is pulled onto the stripped end of the wire and shrunk onto it using a hot air gun. In the process, the inner tinned ring solders the shielding braid to

the wire in the bush. At the same time, both ends of the soldering bush are sealed cleanly and tightly. The quality of the soldered connection can be checked through the transparent bush.

### Note

To avoid damaging the cable with the hot air gun and to focus the air jet onto the soldering point, a suitable reduction nozzle is needed.

### Product specification and dimensions

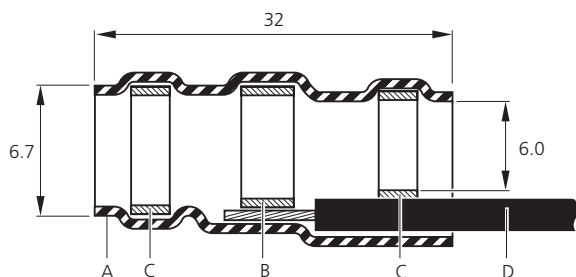

#### Material

##### A Sleeve:

Polyolefin, transparent, heat-shrinkable

##### B Solder preform with flux:

Cd18 per ANSI/J-STD-006 / ROM1 per ANSI/J-STD-004

##### C Meltlabel sealing ring:

Thermally stabilized thermoplastic

##### D Ground lead:

Stranded tin plated copper, size: AWG22 (0,38 mm<sup>2</sup>),  
Raychem polyethylene wire, length: approx. 160mm, color: green

### Strip the cable according to illustration

Dimensions in mm

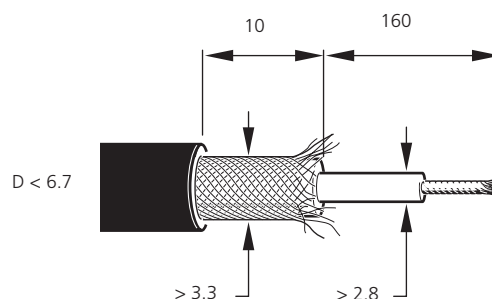

## Two-wire, shielded sensor cables for permanent installation

VIB 90061 : Shielded twisted-pair sensor cable, PUR sheath

VIB 90065 : Stranded sensor cable, silicone sheath and cable armor

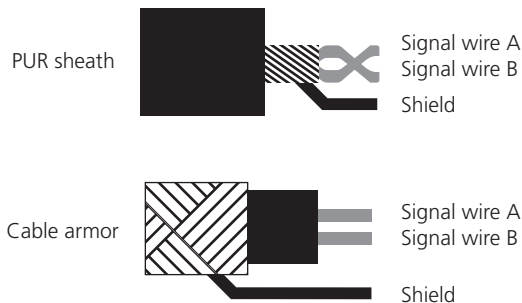

### Application for twisted-pair cable VIB 90061

The cable is used with the VIBROTECTOR vibration transmitter and in the VIBNODE Online Condition Monitoring System with the following transducers:

- VIB 6.195 - CLD-type accelerometer
- VIB 6.172 - ICP-type accelerometer

### Special features

This cable

- is resistant against mineral oil and hydraulic fluid
- is halogen free and flame-retardant (IEC 60332-1-2).
- is notch resistant
- is insensitive against electrical interference
- contains no paint-wetting substances

### Application for stranded cable VIB 90065

Connects the VIBROTECTOR vibration transmitter to a PCS. Resists high temperatures and is used if high mechanical strength is required. Only suitable for use in dry conditions.

### Special features

The stranded cable

- has a wide temperature range: -50°C...+180°C
- has an outer sheath which is covered with a tight braid of galvanized steel wires as mechanical protection for the cable and for electrical screening.
- is halogen free and flame-retardant (IEC 60332-1-2).

### Order information

Add the required cable length to the order number.

Example: Twisted-pair cable, 250 meters

Order no.: VIB 90061-250

### Technical data

PARAMETER		VIB 90061	VIB 90065
Electrical	Char. impedance	72 Ohm	87 Ohm
	Capacitance (w/w)	approx. 86 nF/km ±10%	approx. 73 nF/km
	Inductance	approx. 0.75 mH/km	approx. 0.55 mH/km
	Nominal voltage $U_0/U$	300 / 500 V	
Cable design	Conductor	2 x 0.50 mm <sup>2</sup>	2 x 0.75 mm <sup>2</sup> , fine wire
	Insulation	Co-polymer	silicone-based
	Stranding	twisted-pair	stranded together
	Shielding	Cu braid, tin-coated	Steel wire braiding
	Sheath	PUR Polyurethane, black	silicone-based, glass fibre wrapping, galvanized steel wires
Mechanical	Temperature range	-40°C ... + 85°C, static	-50°C ... + 180°C
	Bending radius, flexing	> 84 mm	> 160 mm
	-, static	> 34 mm	> 30 mm
	Outer diameter	approx. 5.6 mm	approx. 8 mm
	Weight	--	90.5 kg/km
	Special features	halogen free and flame retardant (IEC 60332-1-2)	
Signal wire color code	BN (brown), WH (white)	BN (brown), BU (blue)	

C

# VIB 90070 : Multi-core twisted-pair sensor cable

1

2

3

4

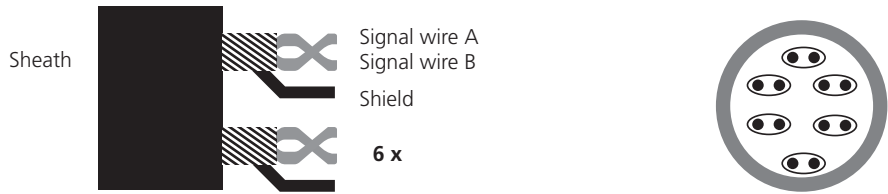

5

### Application

The multi-core cable combines up to 6 sensor cables (VIB 90061) in the VIBROWEB online condition monitoring system.

6

### Note

The twisted-pair cable design minimizes crosstalk. The overall shielding reduces interference of adjacent lines.

A

### Order information

Add the required cable length to the order number.

Example: Multi-core sensor cable, 250 meters  
Order no.: VIB 90070-250

Bundle: 500 meters on cable drum

### Technical data

PARAMETER		VIB 90070
Electrical	Characteristic impedance	approx. 65 Ohm
	Mutual capacitance (A/A)	approx. 140 nF/km
	Inductance	approx. 0.65 mH/km
Cable design	Conductor	6 x 2 x 0.25 mm <sup>2</sup> , Cu, fine-wire strands
	Shielding	Pair screening: wrapping of Cu wires Outer shield: Cu braid, tinned
	Outer sheath	PUR, black, halogen free, UV stabilized
Mechanical	Temperature range	-40°C ... + 80°C, static
	Outer diameter	approx. 17.5 mm ± 0.5 mm
	Bending radius, static	> 108 mm
	Signal wire color code	in each pair: one wire white (WH), 2nd wire acc. to DIN 47100

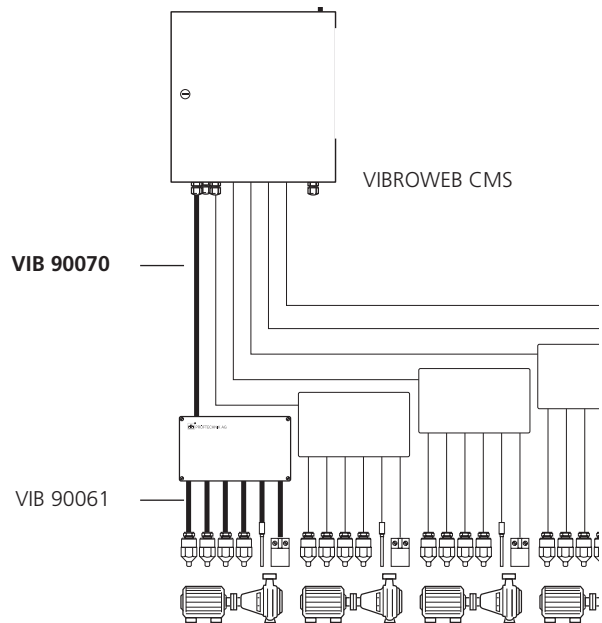

## VIB 90030 : Industrial Ethernet cable for WEARSCANNER (CAT5)

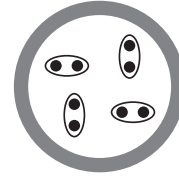

### Application

This multi-core cable is used as a data and power cable for the WEARSCANNER particle counter.

### Note

The twisted-pair cable design minimizes crosstalk. The overall shielding reduces interference of adjacent lines.

### Order information

Add the required cable length to the order number.

Example: Ethernet cable for WEARSCANNER, 25 meters  
Order no.: VIB 90030-25

### Accessories

- VIB 6.421 M12 cable connector for power supply and data transmission (8-pin).
- VIB 6.425 M12 cable connector for switching output (5-pin)

### Technical data

PARAMETER		VIB 90030
Electrical	Characteristic impedance	approx. 100 Ohm ± 15 Ohm (1 ... 100 MHz)
	Mutual capacitance (nom.)	approx. 48 nF/km
	Attenuation	33 dB/100m (100 MHz)
	Test voltage	0.7 kV
Cable design	Conductor	4 x 2 x 0.15 mm <sup>2</sup> , Cu braid
	Insulation	PP
	Stranding	twisted-pair
	Shielding	Polyester foil over stranded bundle Polyester foil aluminium-lined Total: Cu braid, tin-coated
	Sheath	PUR, green, drag chain suitable
	Standards fulfilled	flame retardant (IEC 60332-1), halogen free (IEC 60754-2), Category 5e (CAT 5), corrosivity (EN50267-2-3), UL style 20963 (80°C/30V)
Mechanical	Temperature range	-40°C ... + 80°C
	Outer diameter	approx. 6.8 mm ± 0.3 mm
	Bending radius	> 102 mm
	Weight	approx. 56 kg/km

# C Pre-assembled cables for VIBROTECTOR and CLD-/ICP-type accelerometers

- 1 VIB 5.740-X : Pre-assembled sensor cable, silicone sheath and cable armor, straight connector
- VIB 5.741-X : Pre-assembled sensor cable, silicone sheath and cable armor, angled connector

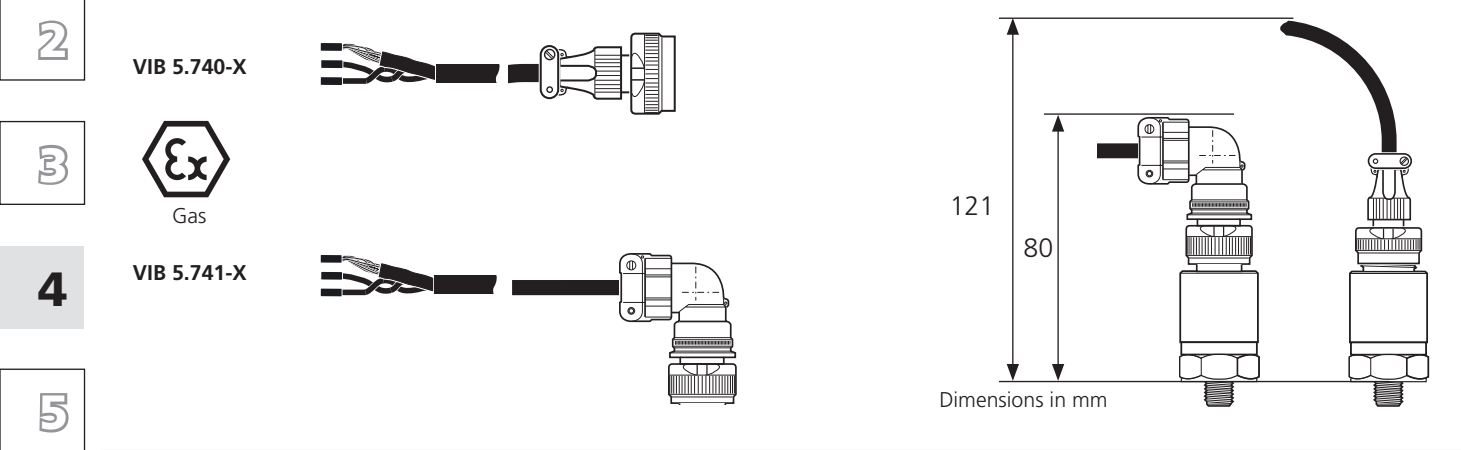

**Application**  
 These sensor cables are already fitted with a suitable connector on the sensor side. The open end of the cable is for the connection to an online CMS or to a PCS (VIBROTECTOR only).  
 The cables can be used to install the following sensors OUTSIDE the hazardous area:  
 VIB 5.73x VIBROTECTOR vibration transmitter  
 VIB 6.172 ICP-type accelerometer  
 VIB 6.195 CLD-type accelerometer

INSIDE the gas-explosion hazardous area the cables can be used with the following sensors:

- VIB 5.73x EX VIBROTECTOR, intrinsically safe
- VIB 6.172XICP ICP-type accelerometer, intrinsically safe

The operation in dust-explosion hazardous areas is not allowed.

**Accessories**  
 VIB 6.776 Junction box for the extension of a twisted-pair sensor cable.

**Technical data**

VIB 5.740-X / VIB 5.741-X		
Cable type	Stranded sensor cable, silicone sheath and cable armor, VIB 90065	
Connector	Type: 2-pin, MIL-C5015 Material: Aluminum alloy Surface: Zinc Nickel (A 240) Order no.: VIB 94010 (straight), VIB 94011 (angled)	
Standard length X	5 meters, 10 meters	
Pin assignment	<b>A</b>	<b>B</b>
Color code	BN - brown	BU - blue

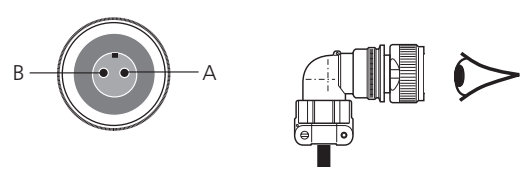

**Example:**

Color code of the sensor signal pin?

SENSOR		KABEL
Type	Pin polarity	Color code
VIBROTECTOR	Signal (+)	BN - brown
VIB 6.172	Signal	BN - brown
VIB 6.195	Signal	BU - blue

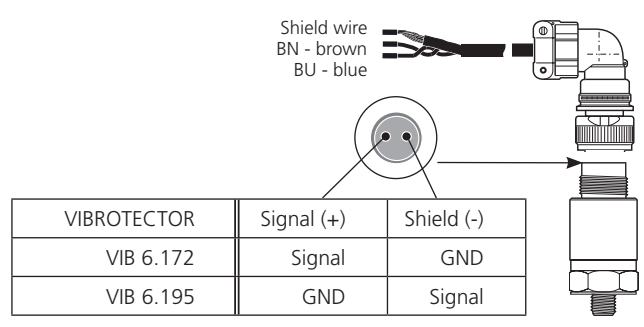



## Pre-assembled cables for VIBROTECTOR and CLD-/ICP-type accelerometers

VIB 5.745-L : Pre-assembled sensor cable, PUR sheath, angled connector

VIB 5.746-L : Pre-assembled sensor cable, PUR sheath, straight connector (Stainless steel VA 1.4305)

VIB 5.745-L



Gas

VIB 5.746-L

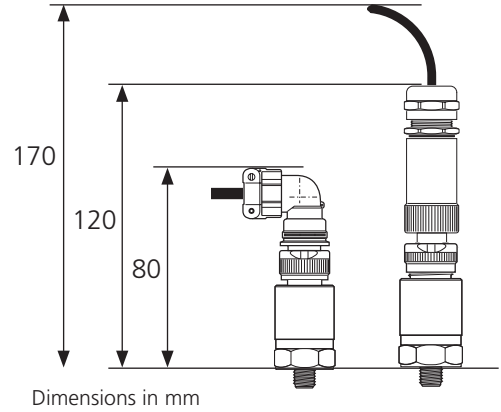
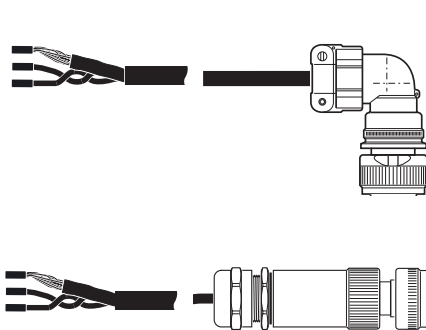

Dimensions in mm

### Application

These sensor cables are already fitted with a suitable connector on the sensor side. The open end of the cable is for the connection to an online CMS or to a PCS (VIBROTECTOR only).

The cables can be used to install the following sensors OUTSIDE the hazardous area:

- VIB 5.73x VIBROTECTOR vibration transmitter
- VIB 6.172 ICP-type accelerometer
- VIB 6.195 CLD-type accelerometer

INSIDE the gas-explosion hazardous area the cables can be used with the following sensors:

- VIB 5.73x EX VIBROTECTOR, intrinsically safe
- VIB 6.172XICP ICP-type accelerometer, intrinsically safe

The operation in dust-explosion hazardous areas is not allowed.

### Accessories

- VIB 6.776 Junction box for the extension of a twisted-pair sensor cable.

### Technical data

CABLE	VIB 5.745-L		VIB 5.746-L	
Cable type	Shielded twisted-pair sensor cable, PUR sheath, VIB 90061			
Connector	Type: 2-pin, MIL-C5015 Material: Aluminum alloy Surface: Zinc Nickel (A 240) Order no.: VIB 94011		Type: 2-pin, MIL-C5015 Material / Surface: Stainless steel VA 1.4305	
Standard length L	5 meters, 10 meters		10m, 15m, 20m	
Pin assignment	<b>A</b>	<b>B</b>	<b>A</b>	<b>B</b>
Color code	WT - white	BN - brown	WT - white	BN - brown

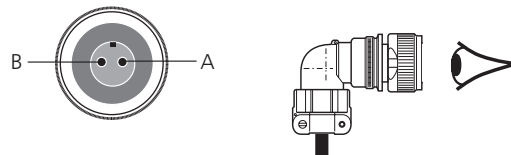

### Example:

Color code of the sensor signal pin?

SENSOR		KABEL
Type	Pin polarity	Color code
VIBROTECTOR	Signal (+)	WT - white
VIB 6.172	Signal	WT - white
VIB 6.195	Signal	BN - brown

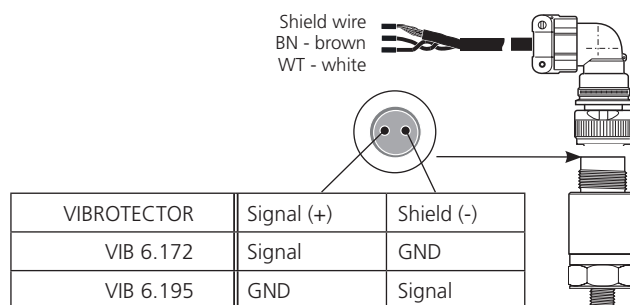

C

# VIB 3.570-L : Pre-assembled cable for intrinsically safe VIBROTECTOR and ICP-type accelerometers

1

2

3

4

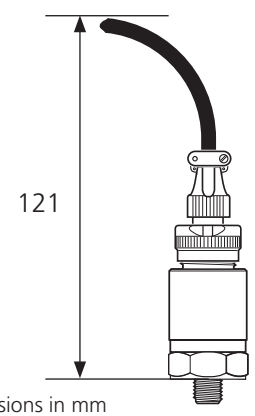

Dimensions in mm



gas & dust

5

**Application**  
This sensor cable is already fitted with a suitable connector on the sensor side. The open cable end is for the connection to an online CMS or to a PCS (VIBROTECTOR only).

6

Inside the hazardous area the cable can be used with the following sensors:

- VIB 5.73x EX VIBROTECTOR EX vibration transmitter
- VIB 6.172 XICP ICP- type accelerometer, intrinsically safe

A

The operation in gas- and dust-explosion hazardous areas is permitted.

**Accessories**

VIB 6.776 Junction box for the extension of a twisted-pair sensor cable.

**Special feature**

The interface between the cable and plug is hermetically sealed (IP 68). This means it is suitable for use under water or in an oil bath (up to 0.8 bar). The shield is not connected with the plug.

**Abbreviations**

- PCS: Process control system
- CMS: Condition Monitoring System
- ICP: Integrated Circuit Piezoelectric (sensor w/ voltage output)

**Technical data**

CABLE	VIB 3.570-L	
Cable type	Shielded twisted-pair sensor cable, PUR sheath, VIB 90061	
Connector	Type: 2-pin, MIL-C5015 Material: Aluminum alloy Surface: Zinc Nickel (A 240) Order no.: VIB 94010	
Standard length L	6 meters, 12 meters	
Pin assignment	<b>A</b>	<b>B</b>
Color code	WT - white	BN - brown

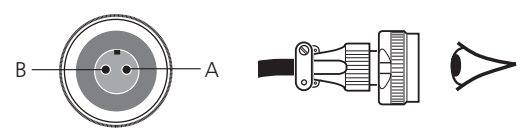

**Example:**

Color code of the sensor signal pin?

SENSOR		CABLE
Type	Pin Polarity	Color Code
VIB 6.172XICP, ICP-type accel.	Signal	WT - white
	GND	BN - brown
VIBROTECTOR EX	Signal (+)	WT - white
	Shield (-)	BN - brown

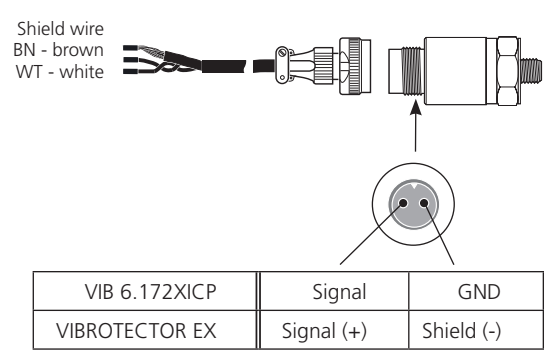

## Sensor cable for hybrid triaxial accelerometers

VIB 3.575-10 : Sensor cable for hybrid triaxial accelerometers (VIB 6.215 / VIB 6.216), 10 meters

VIB 3.575-20 : Sensor cable for hybrid triaxial accelerometers (VIB 6.215 / VIB 6.216), 20 meters

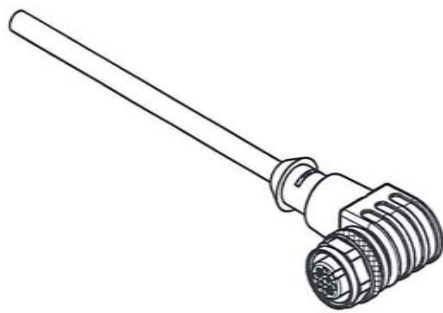

VIB 3.575-10

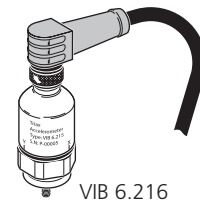

VIB 6.216

### Application

This sensor cable is used to connect the hybrid triaxial accelerometers (type: VIB 6.215 or VIB 6.216) to the VIB-GUARD online CMS\*.

\*CMS: Condition Monitoring System

### Plug pin allocation

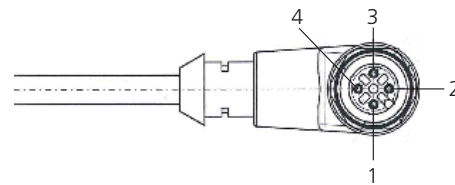

VIB 3.575-10 / VIB 3.575-20	
Cable sheath	PUR UL, black
Pin: color code	1: BN - brown 2: BU - blue 3: BK - black 4: drain wire (shield)

C

**VIB 5.771 : Pre-assembled VIBREX cable**

1

VIB 5.771 =

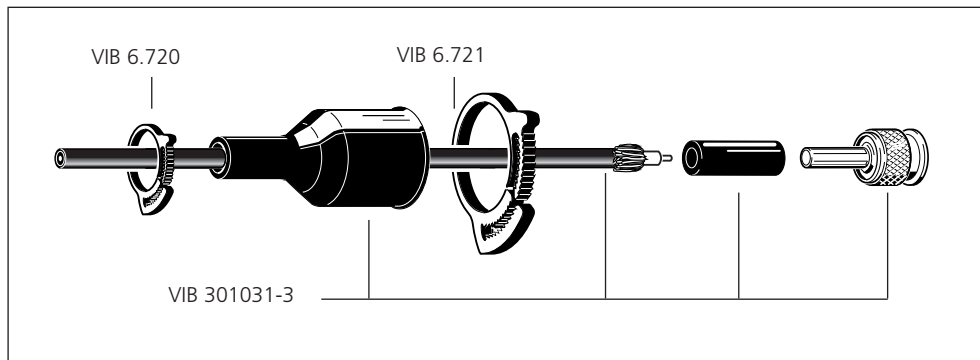

2

3

4

5

6

A

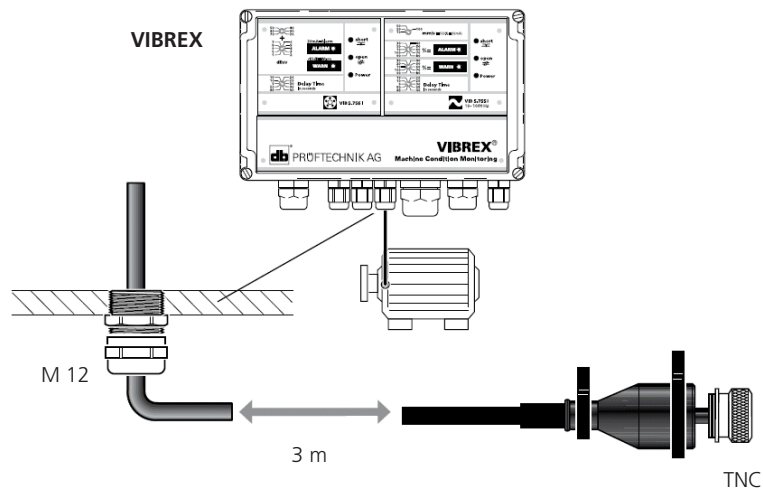
**Application**

This coaxial cable is used by default for the connection of industrial accelerometers (type: VIB 6.1xx) to the VIBREX basic unit. The cable is 3 meters long.

**Cable type**

In this cable the coaxial cable VIB 90008 is used.

**Accessories**

VIB 6.770/9 Junction box for the extension of a single coaxial sensor cable.

VIB 6.775/9 Junction box for the extension of two coaxial sensor cables.

## Pre-assembled VIBNODE cables

VIB 309007-6 : Pre-assembled twisted-pair VIBNODE cable, PUR sheath, 6 meters long

VIB 309007-10 : Pre-assembled twisted-pair VIBNODE cable, PUR sheath, 10 meters long

VIB 309007-15 : Pre-assembled twisted-pair VIBNODE cable, PUR sheath, 15 meters long

VIB 309007-20 : Pre-assembled twisted-pair VIBNODE cable, PUR sheath, 20 meters long

VIB 7.115-6 : Pre-assembled coaxial VIBNODE cable, PVC sheath, 6 meters long

VIB 7.115-12 : Pre-assembled coaxial VIBNODE cable, PVC sheath, 12 meters long

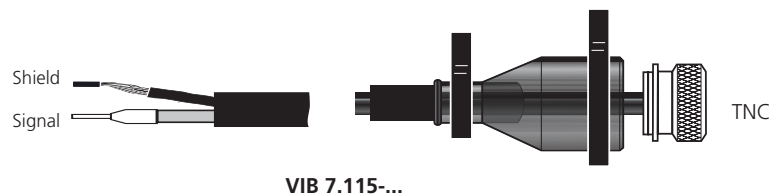

### Application

These cables are used by default for the connection of the following industrial accelerometers to the VIBNODE basic unit.

Coaxial cable, VIB 7.115-...:

VIB 6.1xx Industrial accelerometer w/ TNC socket

Twisted-pair cable, VIB 309007-...:

VIB 6.172 ICP- type accelerometer w/ MIL socket

VIB 6.195 CLD- type accelerometer w/ MIL socket

### Cable type

In these cables the shielded twisted-pair sensor cable with PUR sheath (VIB 90061) and the coaxial cable VIB 90008 is used.

### Accessories

VIB 6.770/9 Junction box for the extension of a single coaxial sensor cable.

VIB 6.775/9 Junction box for the extension of two coaxial sensor cables.

VIB 6.776 Junction box for the extension of a twisted-pair sensor cable.

### Plug pin allocation

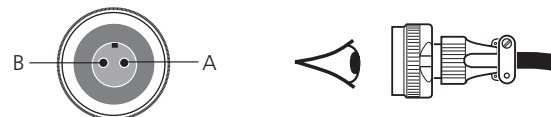

CABLE	VIB 309007-...	
Pin	A	B
Color code	WT - white	BN - brown

C

## Pre-assembled WEARSCANNER cables

1

VIB 6.420-L : Pre-assembled WEARSCANNER cable for power supply & data transmission incl. M12 connector VIB 6.421

VIB 6.426-L : Pre-assembled WEARSCANNER cable for switching output, incl. M12 connector VIB 6.425

2

3



4

5

### Application

These cables are available as an accessory for the WEARSCANNER particle counter. They are used for the connection of the power and data line and for the connection of the switching signal output to a process control system respectively. The maximum cable length is 20 meters.

6

### Cable type

In these cables the Industrial Ethernet cable (VIB 90030) is used.

### Accessories

VIB 6.421 M12 cable connector for power supply and data transmission (8-pin).

VIB 6.425 M12 cable connector for switching output (5-pin)

A

## Devices for separating an intrinsically safe circuit from a non-intrinsically safe circuit

VIB 3.550 : Limiting device for CLD-type accelerometers with intrinsic safety

0 2088 0009 : Safety barrier for ICP-type accelerometers with intrinsic safety

0 2088 0010 : Transmitter supply unit for VIBROTECTOR EX

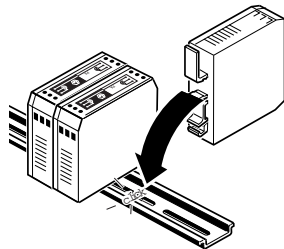

VIB 3.550

CE 0044

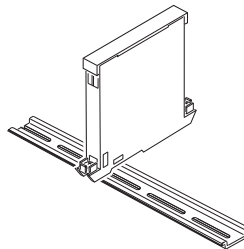

0 2088 0009

CE 0102

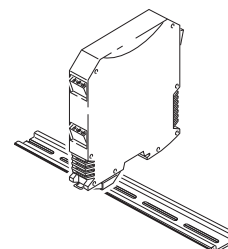

0 2088 0010

CE 0158

### Application

These devices are used to separate an intrinsically safe circuit from a non-intrinsically safe circuit and to limit current and voltage in the intrinsically safe circuit. They are necessary for the operation of sensors in hazardous areas.

For the individual sensor types the following separating devices are provided:

- VIB 3.550 for types VIB 6.1xx DEX  
for types VIB 6.202 XD, VIB 6.203 XD
- 0 2088 0009 for type VIB 6.172 XICP
- 0 2088 0010 for VIBROTECTOR EX, VIB 5.73x EX

The transmitter supply unit 0 2088 0010 also powers the VIBROTECTOR transmitter with auxiliary power.

### Notes regarding limiting device VIB 3.550

The details in the EC type examination certificate TÜV 02 ATEX 1849 must be considered.

Additionally the european installation instructions (EN 60079-14 / EN 61241-14) and the installation notes for hazardous areas annexed in this catalog must be observed.

### Note regarding items 0 2088 0009 / 0 2088 0010

Technical data are available on request.

### Technical data

PARAMETER		VIB 3.550
Electrical	Nominal supply voltage $U_n$	12V DC ( $\pm 10\%$ )
	Current drain	3.5mA DC + AC signal
	Signal	CLD (e.g. $1\mu\text{A}/\text{ms}^2$ )
	Accuracy, signal	sensor accuracy
	Non-intrinsically safe circuit (terminals IN+ IN- PA1)	$U_m = 250 \text{ V AC}$
	Intrinsically safe circuit (terminals OUT+ OUT- PA2)	in type of protection Intrinsic Safety EEx ib IIC  Maximum values: $U_0 = 13 \text{ V}$ $I_0 = 18 \text{ mA}$ $P_0 = 240 \text{ mW}$ $C_0 = 300 \text{ nF}$ $L_0 = 1 \text{ mH}$
General	Temperature range, $T_A$	$-10^\circ\text{C} \dots +50^\circ\text{C}$
	Case material	PA6.6, green
	Environmental protection	IP 20
	Dimensions (HxWxD)	85 x 79 x 22.5 mm
EX	Marking	Ex II (2) G [EEx ib] IIC

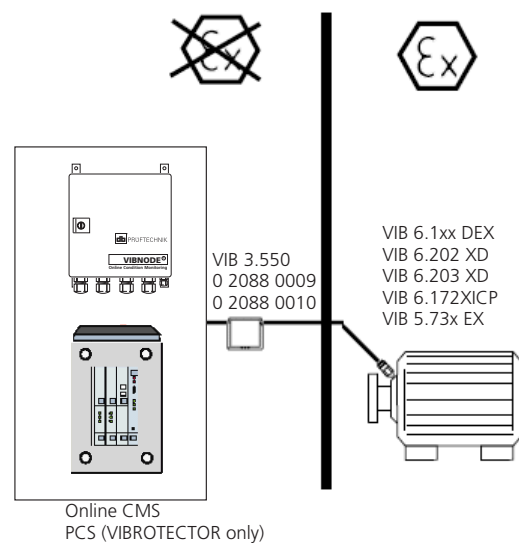

### Abbreviations

PCS: Process control system  
CMS: Condition Monitoring System  
ICP: Integrated Circuit Piezoelectric (sensor w/ voltage output)  
CLD: Current Line Drive (sensor w/ current output)

- C
- 1
- 2
- 3
- 4**
- 5
- 6
- A

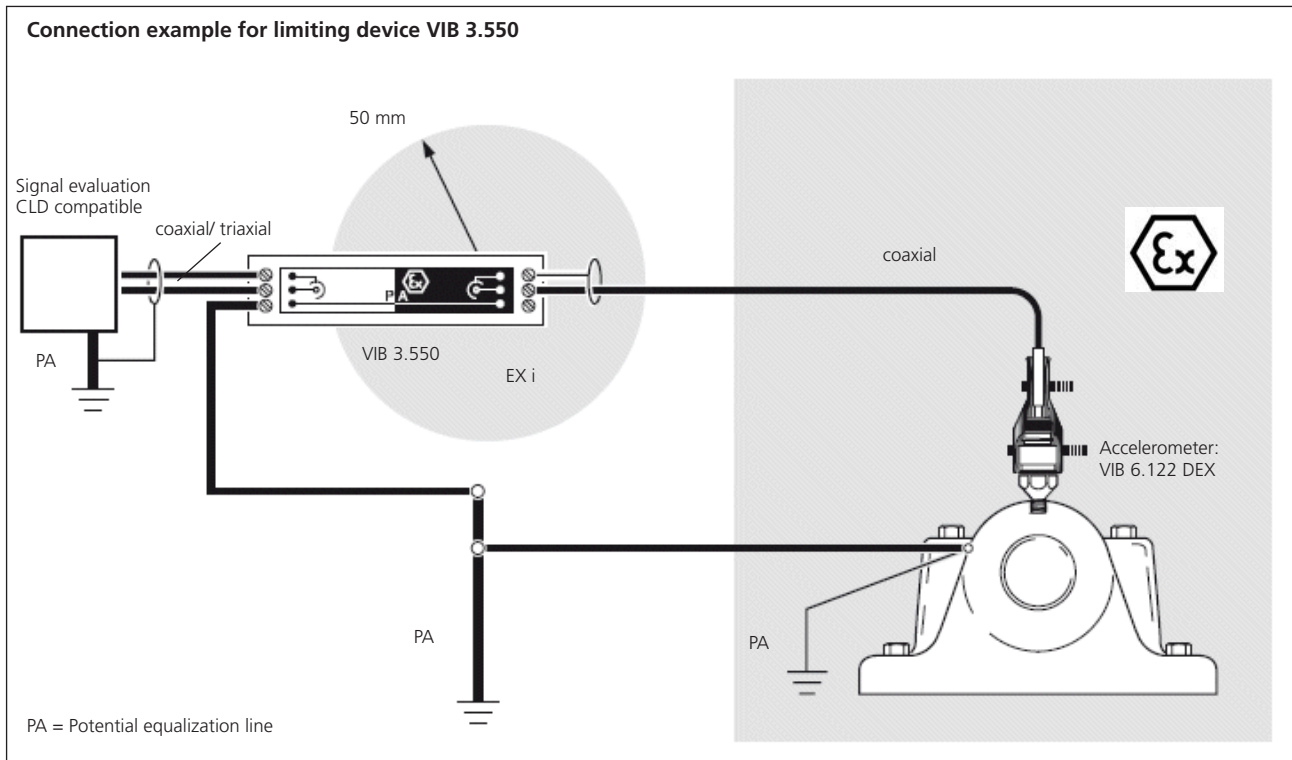

For more connection examples, see Appendix



## Junction boxes for the extension of a sensor cable

VIB 6.770/9 :	Junction box (aluminium) for the extension of a sensor cable, coaxial - coaxial
VIB 6.770/13 :	Junction box (aluminium) for the extension of a sensor cable, coaxial - triaxial
VIB 6.770/9-S :	Junction box (stainless steel) for the extension of a sensor cable, coaxial - coaxial
VIB 6.770/13-S :	Junction box (stainless steel) for the extension of a sensor cable, coaxial - triaxial
VIB 6.776 :	Junction box (plastic) for the extension of a sensor cable, twisted-pair / 2-pin

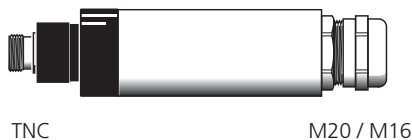

VIB 6.770...

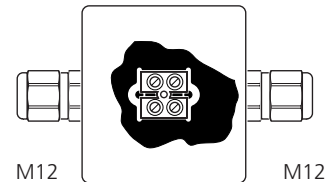

VIB 6.776

### Application

These junction boxes are used to extend a sensor cable or as a cable interface for mobile data acquisition with a data collector. They are easy to mount and protect the cable terminals from dust and water.

Coaxial sensor cables can be extended with either a coaxial or triaxial cable.

The latter option is suitable for an environment subject to electromagnetic fields so that the signal is particularly well shielded from interference. The coaxial sensor cable is kept as short as possible and connected by a TNC plug to the junction box VIB 6.770/13. The TNC connector can be hermetically sealed with a dust cap and clamp rings. Most of the cable length consists of triaxial cable that is connected to the junction box via the threaded fitting.

\* (only VIB 6.770...)

### Note

The junction box VIB 6.770/13 is also suitable for coaxial cables with protective sheath (VIB 6.730).

### Accessories

- VIB 6.700 Dust caps for TNC plug, 10 pcs.
- VIB 6.701 Dust caps for TNC plug, 10 pcs., oil proof
- VIB 6.720 Small clamp rings for dust cap, 10 pcs.
- VIB 6.721 Large clamp rings for dust cap, 10 pcs.
- VIB 7.590 Metric fitting M16, 5 pcs.
- VIB 7.592 Metric fitting M20, 2 pcs.
- VIB 7.593 Metric fitting M12, 5 pcs.

### Technical data

PARAMETER		VIB 6.770/9	VIB 6.770/13	VIB 6.770/9-S	VIB 6.770/13-S	VIB 6.776
General	Case material	Aluminium		Stainless steel		ABS plastic
	In / Out connector	TNC / M16	TNC / M20	TNC / M16	TNC / M20	M12
	Env. protection	IP 65 (TNC plug connected)				

### Dimensions

in mm

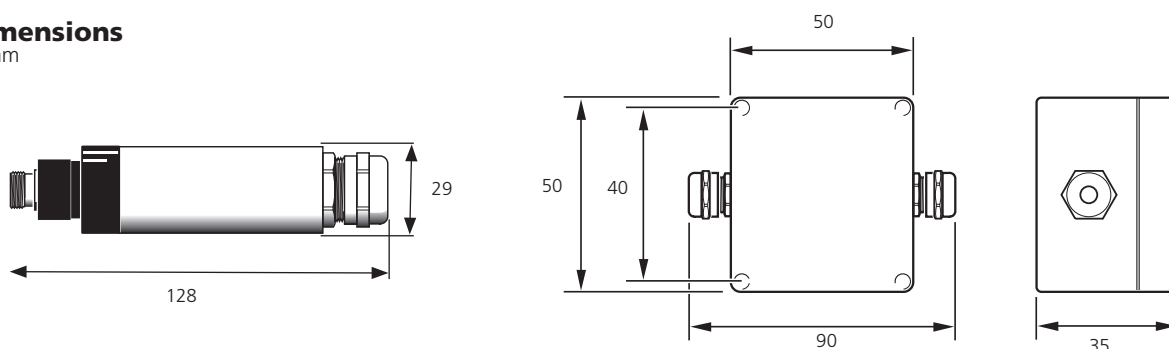

C

**Connection diagram for VIB 6.770/13:**

Extending a coaxial cable with a triaxial cable

1

2

3

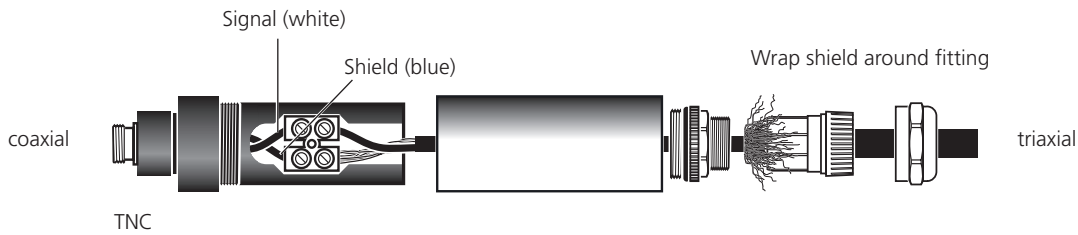

4

**Application example for VIB 6.770/13:**

Online condition monitoring with VIBRONET Signalmaster

5

6

A

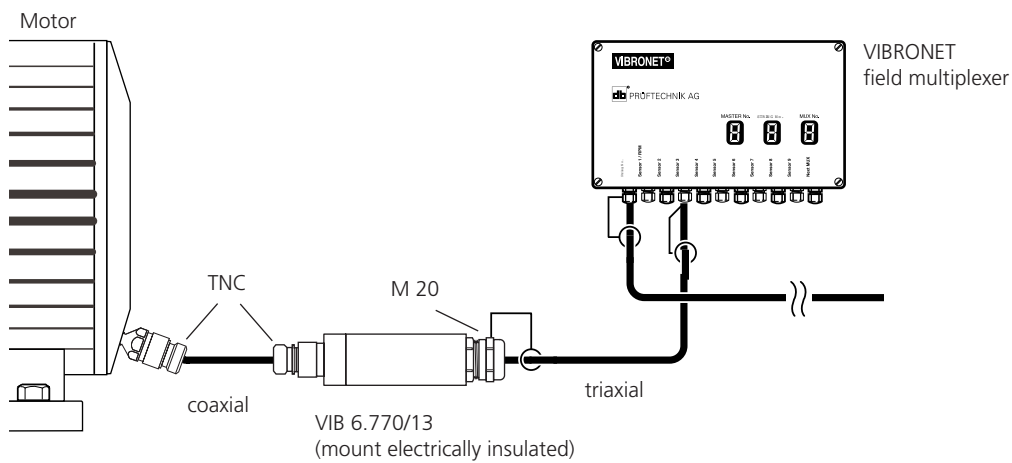

**Application example for VIB 6.770/9:**

Interface for mobile data collection with VIBXPERT, VIBSCANNER, VIBROTIP.

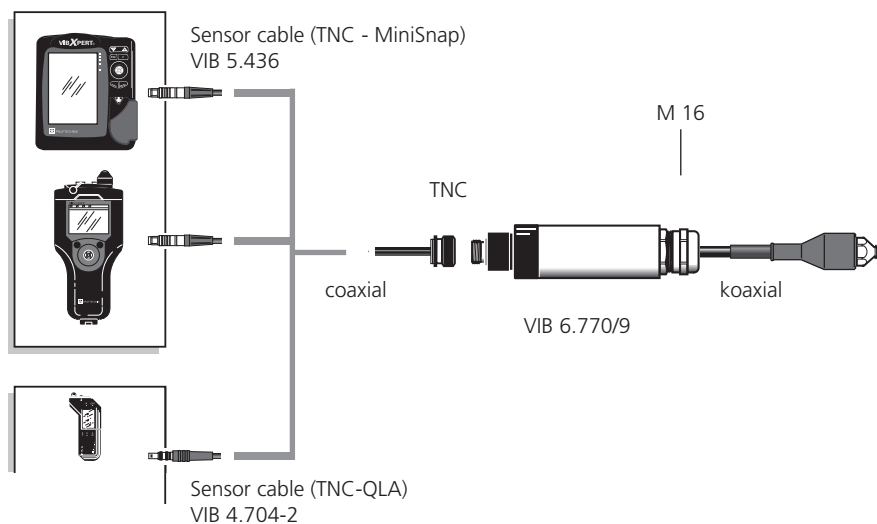

## Junction boxes for the extension of two sensor cables

VIB 6.775/9 : Junction box for the extension of two sensor cables, coaxial - coaxial

VIB 6.775/13 : Junction box for the extension of two sensor cables, coaxial - triaxial

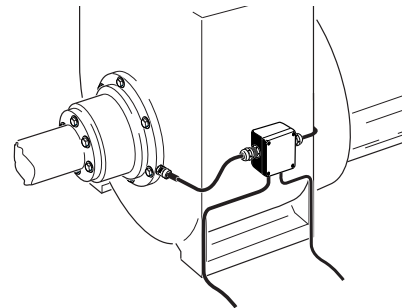
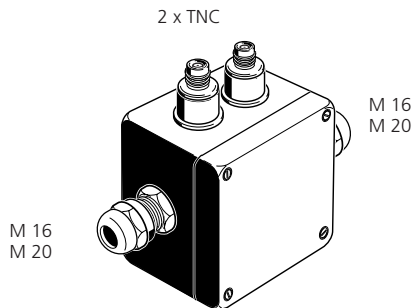

### Application

This junction box is used to extend up to two sensor cables or as a cable interface for mobile data acquisition with a data collector. It is easy to mount and protects the cable terminals from dust and water.

Coaxial sensor cables can be extended with either a coaxial or triaxial cable.

The latter option is suitable for an environment subject to electromagnetic fields so that the signal is particularly well shielded from interference. The coaxial sensor cable is kept as short as possible and connected by a TNC plug to the junction box VIB 6.775/13. The TNC connector can be hermetically sealed with a dust cap and clamp rings.

Most of the cable length consists of triaxial cable that is connected to the junction box via the threaded fitting.

### Note

The junction box VIB 6.775/13 is also suitable for coaxial cables with protective sheath (VIB 6.730).

### Accessories

- VIB 6.700 Dust caps for TNC plug, 10 pcs.
- VIB 6.701 Dust caps for TNC plug, 10 pcs., oil proof
- VIB 6.720 Small clamp rings for dust cap, 10 pcs.
- VIB 6.721 Large clamp rings for dust cap, 10 pcs.
- VIB 7.590 Metric fitting M16, 5 pcs.
- VIB 7.592 Metric fitting M20, 2 pcs.

### Technical data

PARAMETER		VIB 6.775/9	VIB 6.775/13
General	Case material	Aluminium (die cast)	
	Input connectors	2x TNC	
	Output fittings	M16	M20
	Env. protection	IP 65 (TNC plug connected)	

### Connection diagram

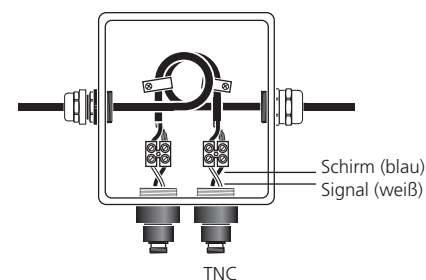

### Dimensions

in mm

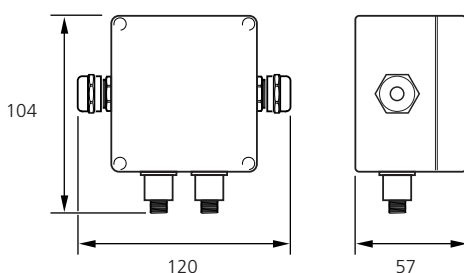

### Mounting holes

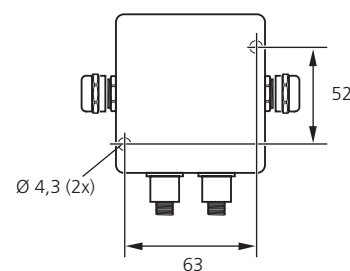

C

## Field multiplexers for VIBRONET Signalmaster Online CMS

1

VIB 8.306 : Field multiplexer with threaded fitting M12 for VIBRONET Signalmaster

VIB 8.306 S : Field multiplexer with threaded fitting M20 for VIBRONET Signalmaster

VIB 8.306 V : Field multiplexer with stainless steel housing for VIBRONET Signalmaster

2

3

4

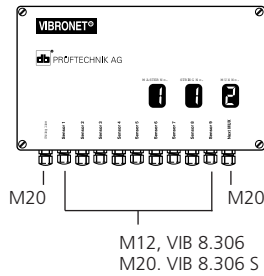

5

VIB 8.306-V

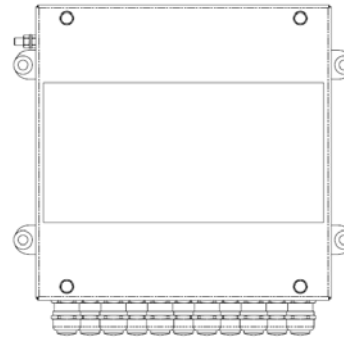

M20

6

A

### Application

These field multiplexers are used as channel switch selectors in the VIBRONET Signalmaster online CMS. The industrial-proofed field multiplexer for up to nine measuring channels reduces the number of signal lines to one single connection and, thus, saves installation costs. The channel is switched automatically by the online CMS. The stainless steel housing enables the multiplexer to be installed in chemically aggressive environments.

### Modularity and Connections

Up to six multiplexers can be connected in series to form a single string line. Up to three string lines can be connected to the VIBRONET Signalmaster where a total of 108 measurement channels are allowed.

Sensor cables for vibration measurements are directly connected to the multiplexer board. For the connection of RPM, temperature, current and voltage sensors special multiplexer modules are required.

### Accessories

VIB 7.590 Metric fitting M16, 5x

VIB 7.592 Metric fitting M20, 2x

VIB 8.310 Temperature modul

VIB 8.312 Process parameters module  
(current / voltage)

VIB 8.313 RPM module

VIB 8.361 LED labels 0-9

### Technical data

PARAMETER		VIB 8.306	VIB 8.306 S	VIB 8.306 V
General	Housing material	Cast aluminum housing, powder coated		Stainless steel (VA)
	Inputs / Outputs	9 sensor inputs, 1 string input, 1 string output		
	Env. protection	IP 65		IP 66
	Temperature range	-40°C ... +80°C		
	Clamping range M12	3.0 ... 6.5 mm		--
	- , M20	7.0 ... 12.0 mm		
	Dimensions LxWxD	224 x 120 x 98 mm		253 x 253 x 120 mm
	Weight	approx. 3 kg		approx. 5 kg
Electrical	Power supply	Approx. 10 V from VIBRONET Signalmaster 'string' output		
	Current consumption	In µA range		
	Interference protect.	Inputs and outputs protected by suppressor diodes		

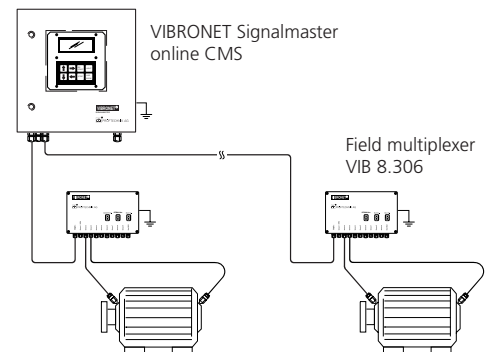

## Field multiplexers with intrinsic safety for VIBRONET Signalmaster Online CMS

VIB 8.306 EX : Field multiplexer for VIBRONET Signalmaster, aluminium housing, intrinsically safe, 224x120 mm

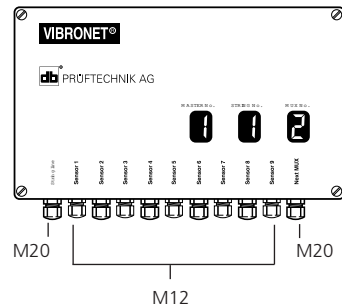

### Application

These field multiplexers can be installed in hazardous areas and are used as channel switch selectors in the VIBRONET Signalmaster online CMS. The industrial-proofed field multiplexer for up to nine measuring channels reduces the number of signal lines to one single connection and, thus, saves installation costs. The channel is switched automatically by the online CMS.

### Modularity and connections

The number of multiplexers in a string line is limited by the interface conditions for installation in hazardous areas and by the OMNITREND software. From the software side a maximum of 6 multiplexers can be connected to a single string line. All sensor cables are connected via appropriate connection modules in the multiplexer.

### Notes on intrinsic safety

The details in the examination certificate of the VIBRONET field multiplexer (type: VIB ..- 8.3 EX) TÜV 02 ATEX 1962 must be considered.

Additionally the following documents must be observed:

- European installation instructions (EN 60079-14:1997, EN 61241-14:2004)
- Installation notes for hazardous areas in this catalog.
- VIBRONET installation instructions VIB 9.520.G

### Accessories

- VIB 7.590 Metric fitting M16, 5x
- VIB 7.592 Metric fitting M20, 2x
- VIB 8.310 EX Temperature module, intr. safe
- VIB 8.313 EX RPM module, intr. safe
- VIB 8.314 EX Vibration module, intr. safe
- VIB 3.550 Limiting device for Current LineDrive accelerometers with intrinsic safety
- VIB 8.361 LED labels 0-9

### Technical data

PARAMETER		VIB 8.306 EX
General	Housing material	Cast aluminum housing, powder coated
	Inputs / Outputs	9 sensor inputs, 1 string input, 1 string output
	Env. protection	IP 65
	Temperature range	-20°C ... +70°C
	Clamping range M12	3.0 ... 6.5 mm
	- , M20	7.0 ... 12.0 mm
	Dimensions LxWxD	224 x 120 x 98 mm
	Weight	approx. 3 kg
Electrical	Power supply	Approx. 10V from VIBRONET Signalmaster 'string' output
	Current consumption	In µA range
	Interference protect.	Inputs and outputs protected by suppressor diodes
EX	Marking	II 2 G EEx ib IIC T4

C

## Connection modules for VIBRONET field multiplexers

1

VIB 8.310 : Temperature module for VIBRONET field multiplexer

VIB 8.312 : Process parameters module (current/ voltage) for VIBRONET field multiplexer

VIB 8.313 : RPM module for VIBRONET field multiplexer

2

VIB 8.310 EX : Temperature module for VIBRONET field multiplexer, intrinsically safe

VIB 8.313 EX : RPM module for VIBRONET field multiplexer, intrinsically safe

VIB 8.314 EX : Vibration module for VIBRONET field multiplexer, intrinsically safe

3

4

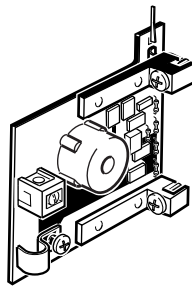

VIB 8.310

5

6

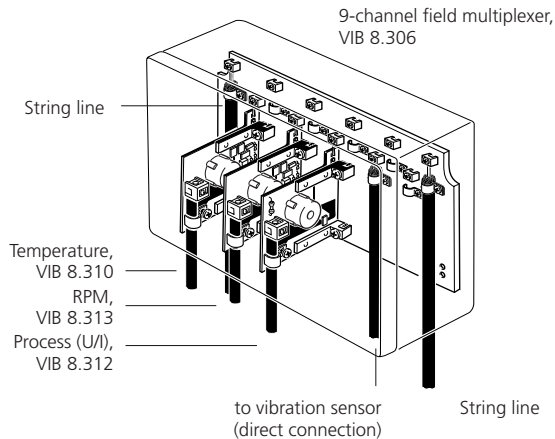

CE 0044

A

### Application

These modules are required for the connection of the appropriate sensor cable in the VIBRONET field multiplexer.

### Description

The VIB 8.310 module converts the resistance value of the Pt100 temperature probe (VIB 6.610) into a digital current signal.

The VIB 8.312 module allows connection to measurement instruments with a standard current or standard voltage output (4-20 mA, 0-10V). This allows monitoring of process parameters, e.g. pressure, flow rate, etc..

The VIB 8.313 module is used to connect a RPM sensor to the multiplexer.

CLD-type accelerometers are connected directly to the multiplexer board. In hazardous areas the connection module VIB 8.314 EX is required for this type of sensor.

### Notes on intrinsic safety

The details in the examination certificate of the VIBRONET field multiplexer (type: VIB ..- 8.3 EX) TÜV 02 ATEX 1962 must be considered.

Additionally the following documents must be observed:

- European installation instructions (EN 60079-14:1997, EN 61241-14:2004)
- Installation notes for hazardous areas annexed in the sensor catalog LIT 01.700.EN.
- VIBRONET installation instructions VIB 9.520.G

### Abbreviation

CLD: Current Line Drive

### Technical data

PARAMETER		VIB 8.310	VIB 8.312	VIB 8.313	VIB 8.314 EX
Electrical	Input	Pt100 temperature probe	Current / Voltage	Inductive proximity sensor	CLD-type accelerometer
	Output	Digitalized current signal			
	Sensitivity	0,385 Ohm/°C	--	2 mA	--
	Current output to sensor	< 2 mA	--	< 4 mA	--
	Voltage output to sensor	< 1 V	< 2.2 V (at connector, current module) 10 kOhm (Input resistance, voltage module)		< 8 V
	Balancing resistor	--	100 Ohm		
General	Temperature range, operation	-20°C ...+80°C			-20°C ...+70°C
	Dimensions	46 x 50 x 2 mm			

## VIB 7.560 : VIBROWEB connection box

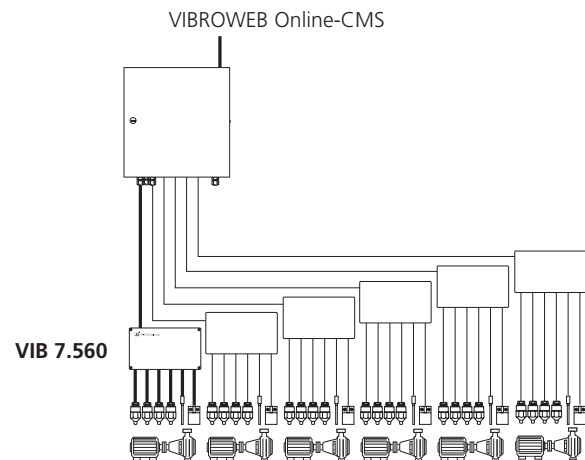
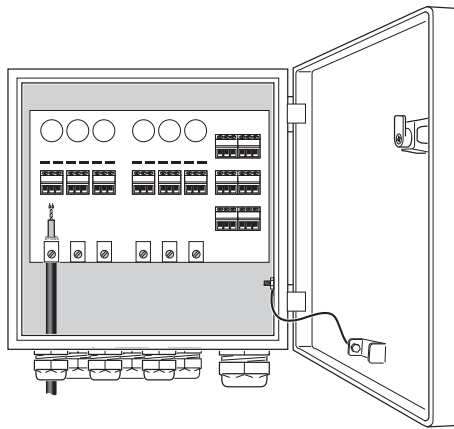

### Application

Up to 6 sensor lines are connected in the VIBROWEB connection box and fed to the VIBROWEB switching cabinet via a multicore shielded cable. If the connection box is mounted near the measurement locations, installation costs can be reduced by avoiding long cables.

If electromagnetic interference is present within the vicinity of the sensor lines, its influence on the measured signals can be suppressed by chokes. All components and connection terminals are provided on a board in an in-

dustrial housing. The glands for the sensor cables and the multicore electrical cable are already installed.

Up to:

- six sensors with 2-line or 3-line connection, or
- three sensors with 4-line connection

can be connected in the VIBROWEB connection box.

### Accessories

- VIB 7.590 Metric fitting M16, 5 pcs.
- VIB 7.591 Metric fitting M25, 2 pcs.

### Dimensions and drilling template

Dimensions in mm

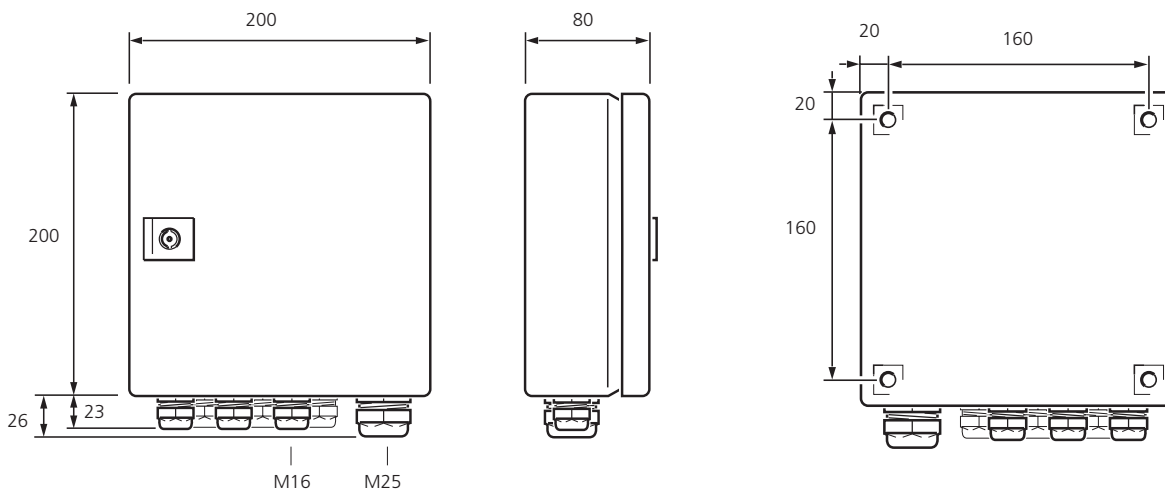

C

## Installation tools for metric cable fittings

1

VIB 7.580 : Open ring spanner, 14x17

VIB 7.581 : Open ring spanner, 19x22

VIB 7.582 : Open ring spanner, 24x27

2

VIB 7.583 : Open ring spanner, 24x25

3

4

5

6

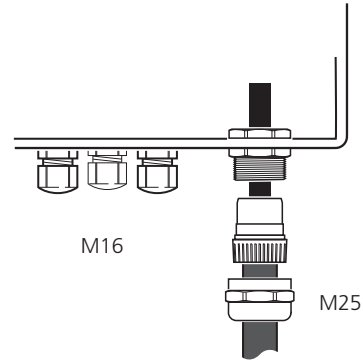
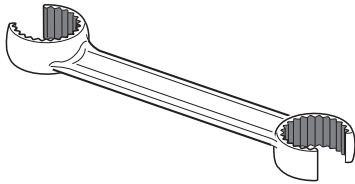

A

### Application

Open ring spanners are used for the installation of metric cable fittings.

### Note

Recommended key sizes for metric cable fittings:

Fitting	Key size
M12	17
M16	22
M20	25
M25	27



## Metric cable fittings and shield clamps

VIB 7.590 : Metric cable fitting M 16, 5 pieces

VIB 7.591 : Metric cable fitting M 25, 2 pieces

VIB 7.592 : Metric cable fitting M 20, 5 pieces

VIB 7.593 : Metric cable fitting M 12, 5 pieces

VIB 7.595 : Shield clamp SK8, 5 pieces

VIB 81060 : Screw driver 2.5 x 35

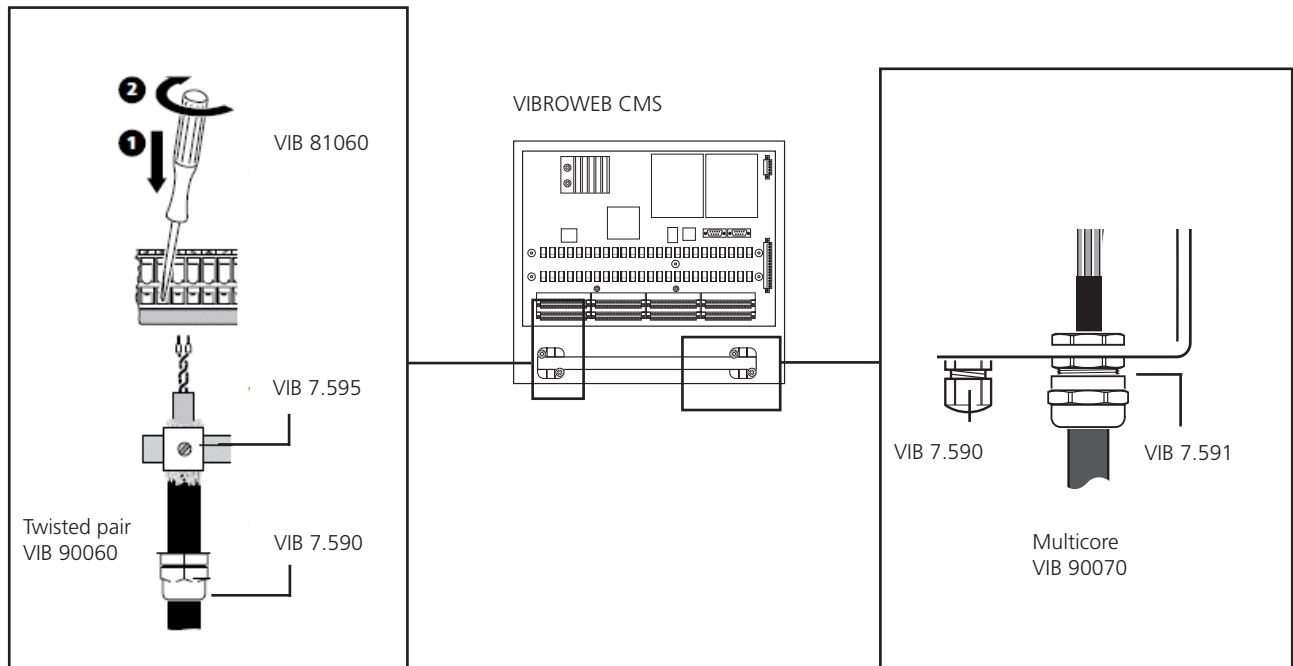

### Application

For the installation of the sensor cable in the CMS switching cabinet, metric threaded fittings in different sizes are available:

M16 is suitable for standard coaxial cable (VIB 90008), standard twisted-pair cable (VIB 90061) and cables with similar dimensions.

The multicore twisted-pair cable (VIB 90070) fits in the M25 threaded fitting.

The M12 threaded fitting is suitable for ethernet cables and control lines.

### Abbreviation

CMS: Condition Monitoring system

The shield clamping clips SK8 are mounted on the shield rails in the CMS switching cabinet and are intended for the shield of the twisted-pair cable, the inner shields of the multicore cable and other potential-free shields.

### Accessories

VIB 7.580 Open ring spanner, 14x17  
 VIB 7.581 Open ring spanner, 19x22  
 VIB 7.582 Open ring spanner, 24x27  
 VIB 7.583 Open ring spanner, 24x25

## C Plugs and sockets for coaxial cable RG 58

1	VIB 91001 : TNC plug to threaded fitting, angled, oilproof
	VIB 91002 : TNC plug to TNC socket, angled
	VIB 91009 : BNC plug to crimp contact, angled
2	VIB 93022 : TNC plug to crimp contact, straight
	VIB 93031 : TNC plug to threaded fitting, straight
	VIB 93033 : TNC socket to TNC socket, straight
3	VIB 93047 : TNC socket to crimp contact, straight
	VIB 93055 : TNC plug to BNC plug, straight
	VIB 93060 : BNC plug to crimp contact, straight
4	VIB 93062 : TNC socket to BNC plug, straight
	VIB 93067 : TNC plug to BNC socket, straight
	VIB 93077 : TNC plug to crimp contact, angled

5

6



VIB 91001

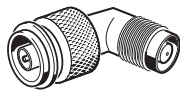

VIB 91002



VIB 91009



VIB 93022



VIB 93031

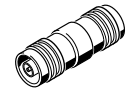

VIB 93033

A

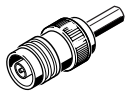

VIB 93047



VIB 93055



VIB 93060

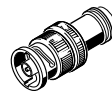

VIB 93062



VIB 93067



VIB 93077

### Application

These plugs and sockets in various designs and shapes are used for connecting sensor cables and for the assembly of coaxial cables (RG 58).

### Accessories

- VIB 81026 Crimping tool for coaxial cable
- VIB 81052 Cutting tool for coaxial cable

## Plug-in connectors for two-wire, shielded sensor cables

VIB 94010 : Plug-in connector, 2-pin, straight

VIB 94011 : Plug-in connector, 2-pin, angled

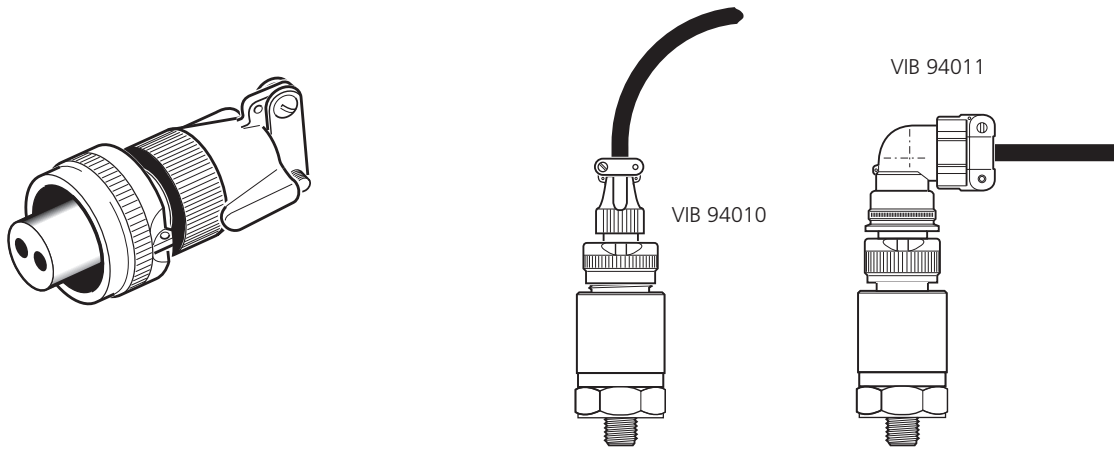

### Application

These connectors are used for the assembly of two-wire sensor cables which are suitable for the following sensors:

- VIB 6.195 CLD-type accelerometer
- VIB 6.172 ICP-type accelerometer
- VIB 6.172XICP ICP-type accelerometer, intrinsically safe (only with straight connector, VIB 94010)
- VIB 5.73.. VIBROTECTOR vibration transmitter
- VIB 5.73..EX VIBROTECTOR vibration transmitter, intrinsically safe

### Technical data

PARAMETER		VIB 94010	VIB 94011
General	Material	Aluminum alloy	
	Surface	Zinc Nickel (A 240); RoHS compliant Protection against salt spray (500h) and shielding acc. to VG95234	
	Clamping range	< 7 mm	
	Specification	MIL-C-5015	
	Special feature	Cable clamp and sleeve	

### Dimensions

in mm

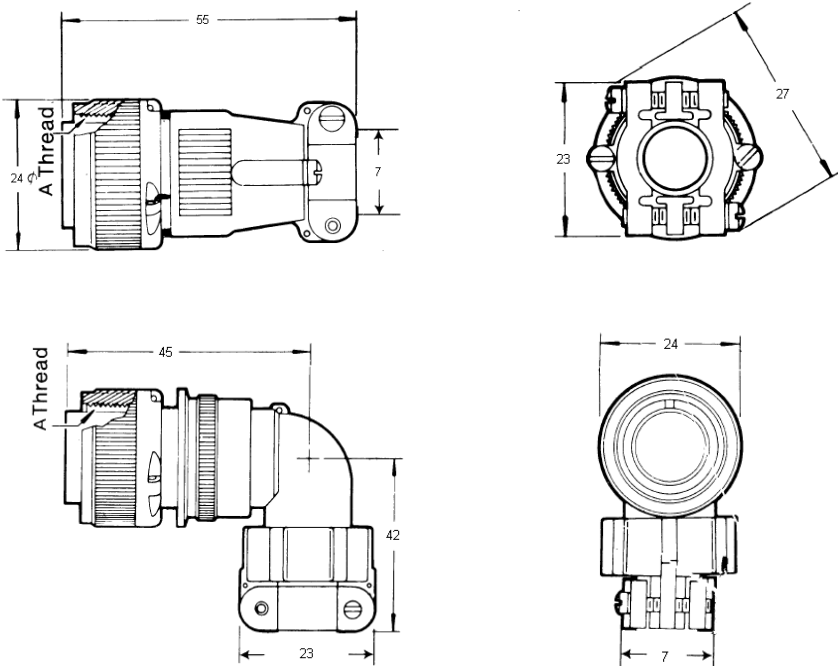

## C Bulkhead connectors for coaxial cable RG 58

VIB 91000 : Chassis connector, TNC socket to crimp contact

VIB 93035 : Dust cap for TNC socket

VIB 93036 F : Bulkhead connector w/ fastening flange, TNC socket to TNC socket

VIB 93036 S : Bulkhead connector single hole screw version, TNC socket to TNC socket

VIB 93056 : Bulkhead connector w/ fastening flange, BNC socket to TNC socket

VIB 93061 : Dust cap for BNC socket

VIB 93090 : Chassis connector, BNC socket to crimp contact

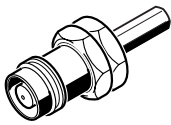

VIB 91000



VIB 93035

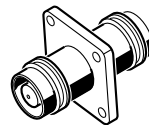

VIB 93036 F

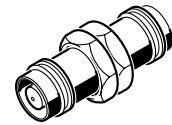

VIB 93036 S

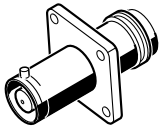

VIB 93056



VIB 93061

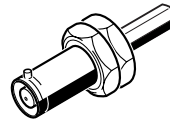

VIB 93090

### Application

Bulkhead connectors are used if sensor cables have to be fed through protective covers, housing covers or similar.

### Notes

Suitable insulating washers are required to electrically insulate the connectors.

The dust caps are attached to a metal cord. To electrically insulate the connector, the dust caps must only come into contact with insulated components.

### Dimensions and drilling template

in mm

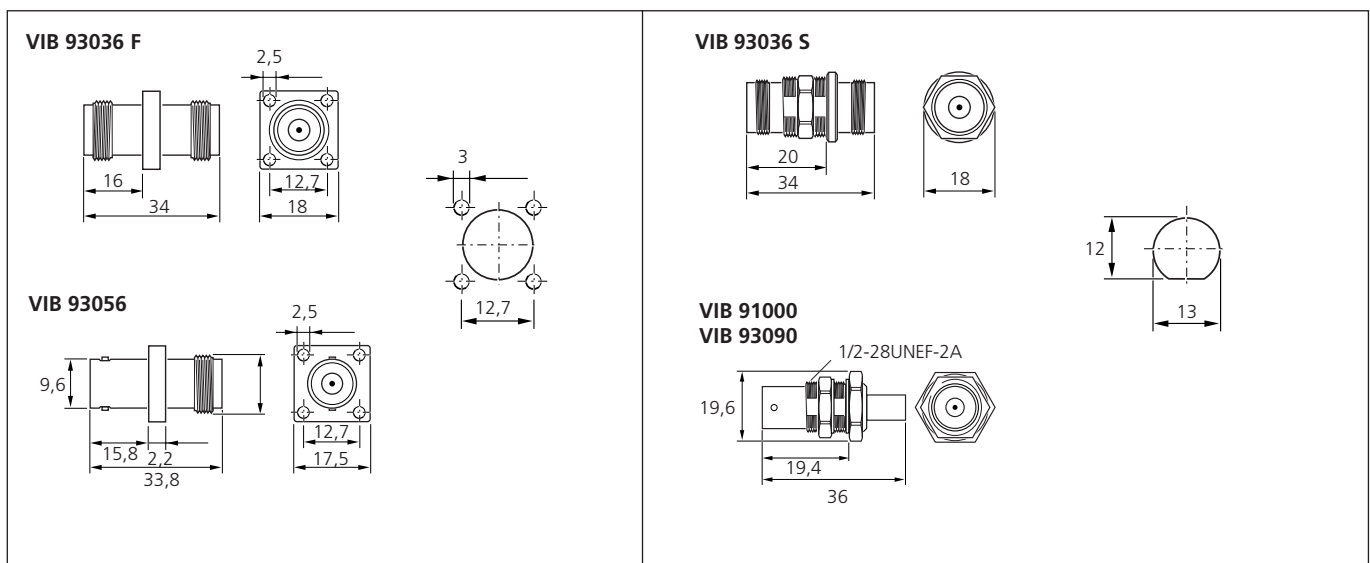

## Dust caps for industrial accelerometers (type VIB 6.1xx)

VIB 6.700 :	Dust cap for industrial accelerometer (type VIB 6.1xx), straight, 10 pcs.
VIB 6.701 :	Dust cap for industrial accelerometer (type VIB 6.1xx), straight, oil-resistant, 10 pcs.
VIB 6.710 :	Dust cap for industrial accelerometer (type VIB 6.1xx), angled, 10 pcs.
VIB 6.711 :	Dust cap for industrial accelerometer (type VIB 6.1xx), angled, oil-resistant, 10 pcs.
VIB 6.720 :	Clamp for dust cap, cable end, 10 pcs.
VIB 6.721 :	Clamp for dust cap, sensor end, 10 pcs.
VIB 6.722 :	Dust cap sleeve, 10 pcs.

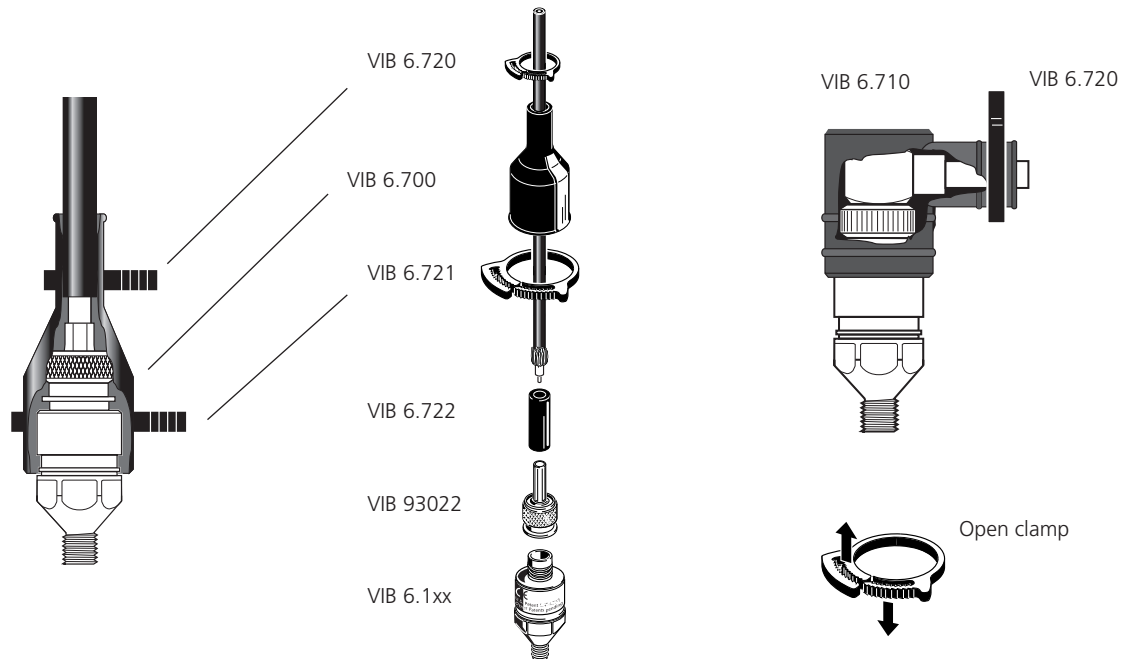

### Function

The dust cap with the appropriate clamp seal and relieve stress on the connection between the accelerometer and cable. The clamp can be mounted and undone without the need for any tools.

### Notes

In hazardous areas only the straight caps\* (VIB 6.700 / VIB 6.701) may be used, because they can be sealed according to the requirements (IP 67).

The angled caps (6.710 VIB / VIB 6.711) must not be used in hazardous areas, as they can be sealed only with the cable-ended clamp (IP 65).

Only silicone-free dust caps may be used in paint shops.

### Technical data

PARAMETER	VIB 6.700	VIB 6.710	VIB 6.701	VIB 6.711	VIB 6.720	VIB 6.721	VIB 6.722	
General	Material	Silicone (Silopren HV)		Vitone (FKM polymer, P-60 120 black)		Nylon 66, thermally stabilized		Acrylonitrile-Butadiene-rubber (NBR)
	Resistance	Ozone, weathering, ageing, UV emission, hot water, steam (up to 130°C / 266°F), aliphatic hydrocarbons (mineral oils)		Ozone, weathering, ageing aliphatic, aromatic and chlorinated hydrocarbons (e.g. mineral oils, greases, fuels and mixtures), anorganic acids, chemicals, silicone oil or greases		Industrial solvents, fuels, oils, greases, weathering		silikone free, oil-resistant
	Temperature range	-55°C ... + 180°C		-30°C ... + 200°C		-40°C ... +120°C		---
	Env. protection	IP 67**	IP 65	IP 67**	IP 65	---		---
	Size range, clamp	---		---		12.2...14.8 mm	20.5...23 mm	---

\* w/ dust cap sleeve, protective sheath or triaxial cable (if applicable, see next page)

\*\* w/ clamps VIB 6.720 & VIB 6.721 and dust cap sleeve VIB 6.722

C

### Installation examples

1

2

3

4

5

6

A

Standard coaxial cable RG 58  
VIB 90008-x

Standard coaxial cable RG 58  
VIB 90008-x

Standard triaxial cable  
VIB 90080-x

Dust cap sleeve  
VIB 6.722

Protective sheath  
VIB 6.730

Heat-shrinkable sleeve

Dust cap  
VIB 6.700

Dust cap  
VIB 6.700

Dust cap  
VIB 6.700

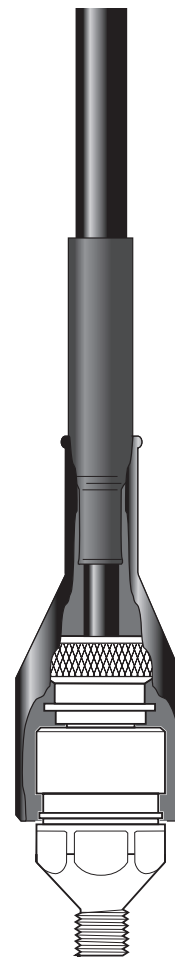
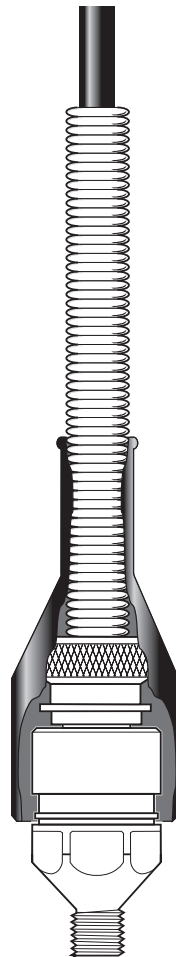

## VIB 8.745 : Installation checker

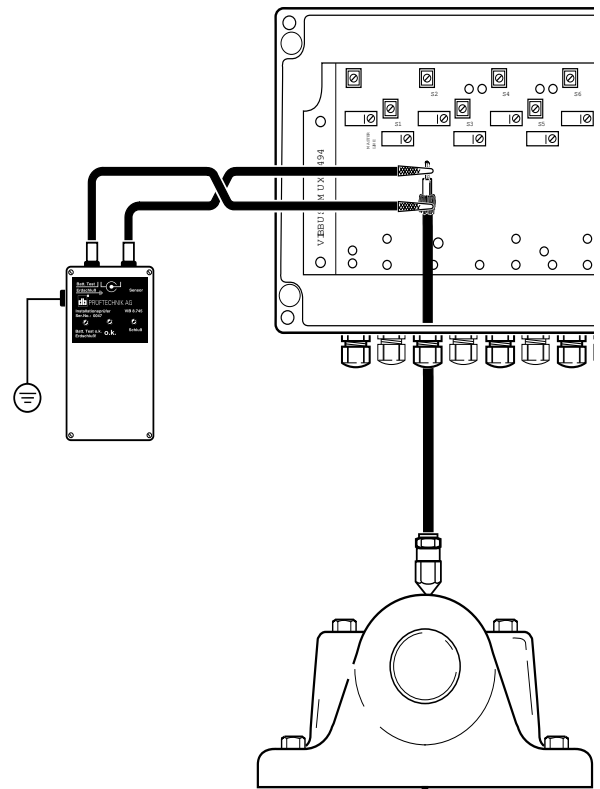
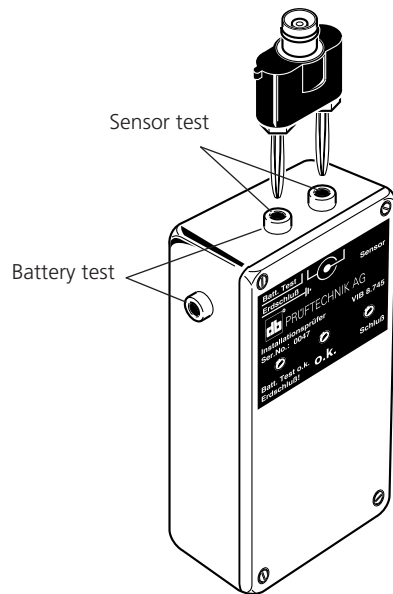

### Application

The VIB 8.745 installation checker lets you ensure that remotely mounted accelerometers are properly connected. The unit features three LED's which light up according to the status of the connection:

- Green LED = Installation is correct
- Red LED = Short circuit
- Yellow LED = Ground loop

Additionally, battery test terminals allow battery voltage checking: if voltage is less than 5V, the yellow LED lights up.

If the battery voltage is sufficient, yet none of the LED's lights up, then the connection to the sensor has been broken.

### How to check the installation:

Attach the leads from the accelerometer to be checked via the QLA jacks on the top of the installation checker, if necessary using the VIB 4.705 QLA-BNC plug adapter.

Alternatively, the sensor leads may be connected to the jacks on the top of the unit via BNC or TNC adapter (not included), as shown above, or using ordinary banana plugs.

C

## Sealing of the cable connection for use in liquids / in hazardous areas (IP68)

1

- VIB 6.760 : IP 68 option for industrial accelerometer (type VIB 6.1xx)
- VIB 6.761 : IP 68 option for industrial accelerometer (type VIB 6.1xx), short version

2

3

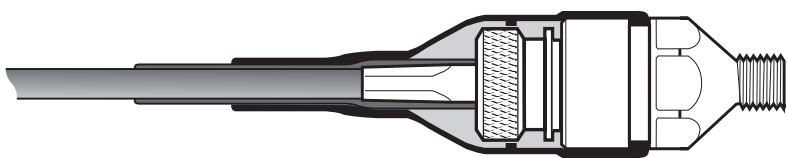

4

Coaxial cable, oil-resistant  
VIB 90093-L\*

Shrink-fit part,  
incl. TNC plug  
VIB 6.760  
VIB 6.761

Industrial accelerometer  
VIB 6.125-RIP  
VIB 6.129-IP

5

\*L= cable length in meters

6

**Function**  
The IP 68 option is used to hermetically seal the connection between sensor and cable and relieve strain.

**Application**  
Vibration measurements in gearboxes and submerged pumps with the industrial accelerometers for high ambient temperatures (type VIB 6.125 RIP and VIB 6.129 IP). The IP 68 option is also suitable for applications in hazardous areas (only with accelerometers type VIB 6.125 IDEX or VIB 6.129 IDEX respectively).

**Order information**  
The shrink-fit part, the cable and the accelerometer are factory-built. Please indicate accelerometer type, option IP68 and cable with length when ordering.

Example: VIB 6.125 RIP / VIB 6.760 / VIB 90093-10  
= industrial accelerometer with M8 thread, shrink-fit part IP68 and 10-meter coaxial cable.

**Test certificate**  
The test certificate for the accelerometer VIB 6.125-RIP can be ordered separately (VIB 2.550).

**Technical data**

PARAMETER		VIB 6.760	VIB 6.761
General	Env. protection	IP 68 (dust and waterproofed)	
	Admissible sensor	VIB 6.125-RIP, VIB 6.129-IP VIB 6.125-IDEX, VIB 6.129-IDEX	
	Temperature range	defined by sensor	
	Max. depth / pressure	8 m in water / zero pressure in oil	
	Resistance	Aircraft fuel F40, lubricating oil O-156, hydraulic fluid H515, diesel fuel F54, motor fuel F46, water, seawater	
	Mounting height	> 140 mm	> 120 mm

**Application example:**  
Vibration monitoring on a submerged pump

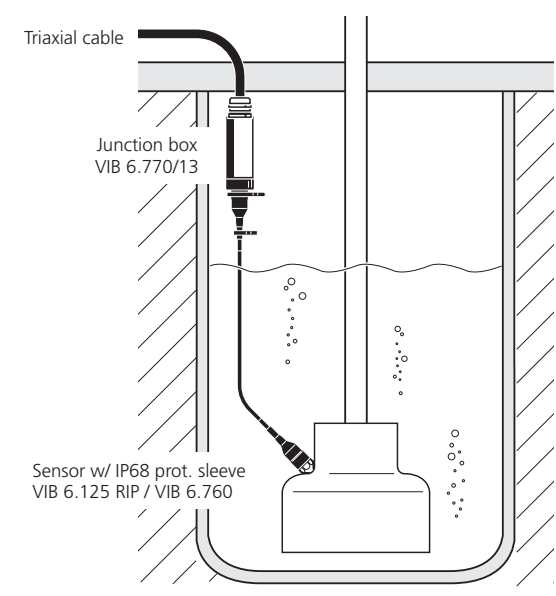



# Chapter 5

## Sensor cables and connection adapters for mobile data collectors

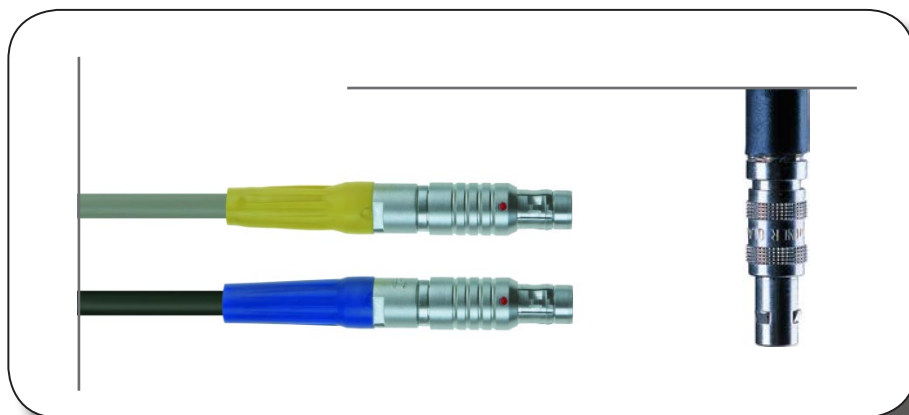

C

## Contents: Sensor cables and connection adapters for mobile data collectors

1

2

3

4

5

6

A

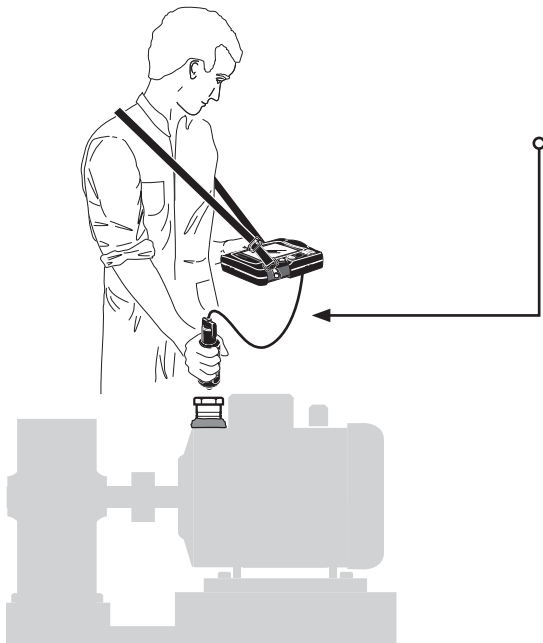

Order no.	Description	Page
VIB 321926-2	Spiral cable, TNC-QLA	150
VIB 4.701-2 VIB 4.701-5 VIB 4.702-2 VIB 4.702-5 VIB 4.704-2 VIB 4.704-5	Straight cable, BNC - QLA, 2 m -, BNC - QLA, 5 m -, Microdot - QLA, 2 m -, Microdot-QLA, 5 m -, TNC - QLA, 2 m -, TNC - QLA, 5 m	150
VIB 4.750-5	Cable extension for RPM sensor, 5m	157
VIB 5.332	Keyphasor adapter for machine protection systems, VIBXPERT / VIBSCANNER	159
VIB 5.332 X	Keyphasor adapter for machine protection systems, VIBSCANNER EX / VIBXPERT EX	160
VIB 5.333	Cable adapter for TTL / strobe output, VIBXPERT	161
VIB 5.336	Cable adapter for triaxial accelerometer VIB 6.655, VIBXPERT	162
VIB 5.339	Cable extension for Current Linedrive accelerometer, 8 meters	149
VIB 5.341 VIB 5.342 VIB 5.343 VIB 5.344	VST 24V adapter for VIBXPERT Analog cable for VST 24V adapter Digital cable for VST 24V adapter VIBROTECTOR cable for VST 24V	163
VIB 5.345-6 VIB 5.422	Cable extension for VIB 5.422 Spiral connection cable for ICP-type accelerometer, MIL-connector	152
VIB 5.346 VIB 5.346-MUX	VIBXPERT II connection cable for VIBRONET field multiplexer VIB 8.306 BNC adapter for cable VIB 5.346	173
VIB 5.431	Cable for analog signal output	158
VIB 5.432-2,9	Connection cable for RPM sensors	157
VIB 5.433 VIB 5.434	Cable adapter for signal-low voltage Cable adapter signal-low current	153
VIB 5.433 X	Cable adapter for signal-low voltage, VIBXPERT EX	155
VIB 5.436 VIB 5.437-2,9 VIB 5.437-5	Spiral cable for CLD-type accelerometer -, straight 2.9 m -, straight 5 m	147
VIB 5.438-0.5	Cable for ICP-type accelerometer, BNC	152
VIB 5.439	Cable for Pt100 temperature probe, VIBSCANNER	165
VIB 5.443	Connection cable for TTL trigger sensors	157
VIB 5.444-5	Universal cable extension for analog measurement channel, 5 meters	148
VIB 5.445 VIB 5.446	Manual channel switch, VIBSCANNER Automatic channel switch, VIBSCANNER	166
VIB 5.449	Cable adapter for VIB 6.195 / VIB 6.172	168
VIB 4.705	BNC to QLA cable adapter, VIBROTIP	169
VIB 6.780	Terminal holder for bulkhead connectors	170
VIB 6.785	SwitchBox - Channel switching unit	171
VIB 8.617	QLA angled plug, VIBROTIP	169
VIB 8.618-1,5 VIB 8.618-5	TIPTECTOR cable, 1,5 m TIPTECTOR cable, 5 m	151
VIB 8.746	SPM cable adapter	172
VIB 8.749	Current Linedrive converter	167
VIB 10473	Dust cap for TNC connector	170

## Connection cables for current linedrive accelerometers (VIBSCANNER / VIBXPERT)

VIB 5.436 : Spiral connection cable for current linedrive accelerometer (VIBSCANNER / VIBXPERT)

VIB 5.437-2,9 : Straight connection cable for current linedrive accelerometer, 2.9 meters (VIBSCANNER / VIBXPERT)

VIB 5.437-5 : Straight connection cable for current linedrive accelerometer, 5 meters (VIBSCANNER / VIBXPERT)

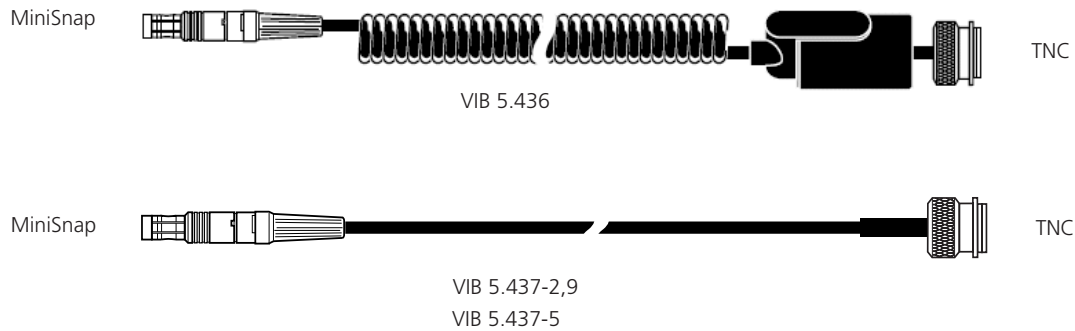

### Application

These cables are used to connect mobile industrial accelerometers with current linedrive output to the following PRÜFTECHNIK data collectors:

- VIBXPERT II
- VIBXPERT I
- VIBXPERT EX
- VIBSCANNER
- VIBSCANNER EX

### Cable lengths

VIB 5.436	0.7 ... 1.8 m
VIB 5.437-2,9	2.9 m
VIB 5.437-5	5 m

### Connection example

VIBCODE / TIPECTOR connected to VIBXPERT II

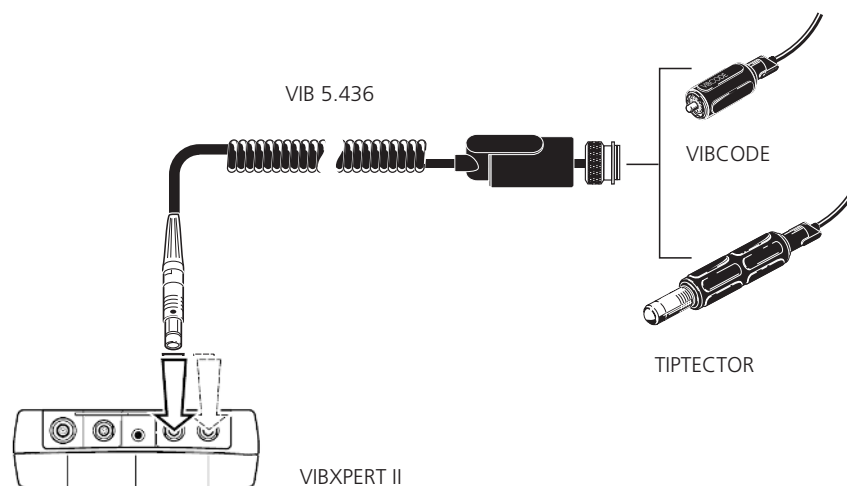

C

## VIB 5.444-5 : Universal cable extension for analog measurement channel, 5 meters

1

2

MiniSnap



MiniSnap

3

4

### Application

With this cable, the analog signal path can be extended by up to five meters.

5

### Extendable sensor cables:

- VIB 5.436 LineDrive spiral cable
- VIB 5.437-2,9 LineDrive cable, straight, 2.9m
- VIB 5.437-5 LineDrive cable, straight, 5m
- VIB 5.438-0,5 ICP cable, BNC connector

- VIB 5.422 ICP cable, MIL connector
- VIB 5.433 Cable for extra-low voltage
- VIB 5.433 Cable for extra-low voltage, VIBXPert EX
- VIB 5.434 Cable for extra-low current
- VIB 5.342 Cable for VST 24V adapter

### Note

For cable lengths greater than 2.9 meters, the EMC immunity of the signal path can be adversely affected.

6

A

### Connection example

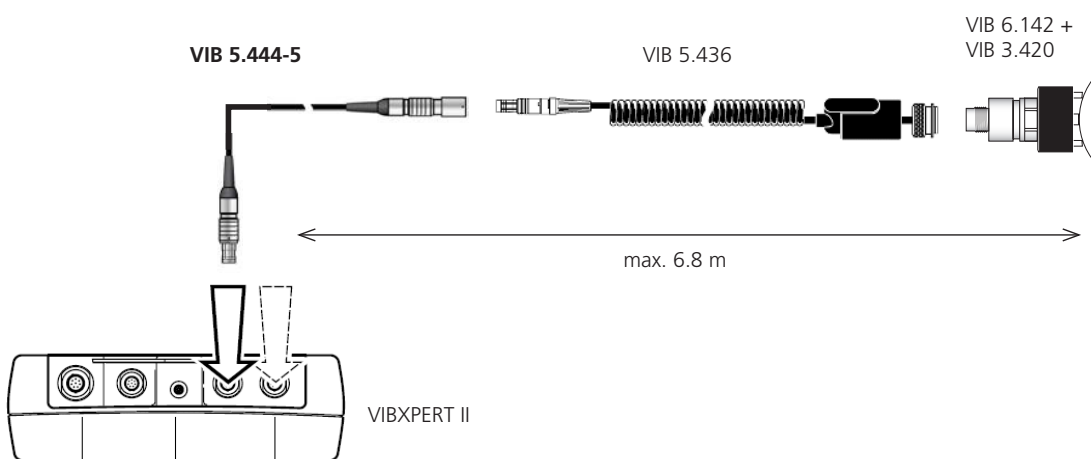

## VIB 5.339: Cable extension for Current Linedrive accelerometer, 8 meters



### Application

With this cable, the Current LineDrive sensor cables can be extended by up to eight meters.

### Note

For cable lengths greater than 2.9 meters, the EMC immunity of the signal path can be adversely affected.

### Extendable sensor cables:

- VIB 5.436 LineDrive spiral cable
- VIB 5.437-2,9 LineDrive cable, straight, 2.9m
- VIB 5.437-5 LineDrive cable, straight, 5m

### Connection example

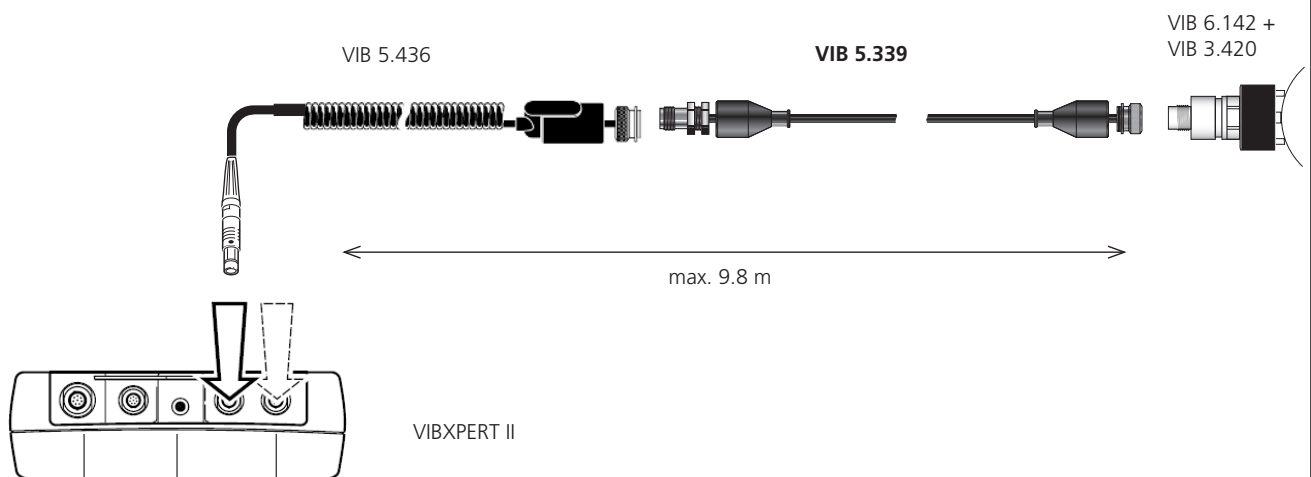

C

## Connection cables for current linedrive (CLD) accelerometers (VIBROTIP)

1

VIB 4.701-2 : Straight connection cable for CLD-type accelerometer, BNC angled plug, 2 meters (VIBROTIP)

VIB 4.701-5 : Straight connection cable for CLD-type accelerometer, BNC angled plug, 5 meters (VIBROTIP)

2

VIB 4.702-2 : Straight connection cable for CLD-type accelerometer, Microdot angled plug, 2 meters (VIBROTIP)

VIB 4.702-5 : Straight connection cable for CLD-type accelerometer, Microdot angled plug, 5 meters (VIBROTIP)

3

VIB 4.704-2 : Straight connection cable for CLD-type accelerometer, TNC angled plug, 2 meters (VIBROTIP)

VIB 4.704-5 : Straight connection cable for CLD-type accelerometer, TNC angled plug, 5 meters (VIBROTIP)

4

5

6

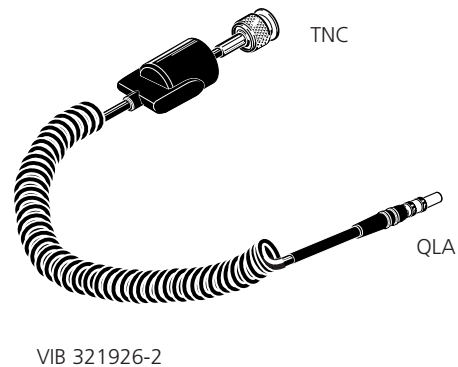
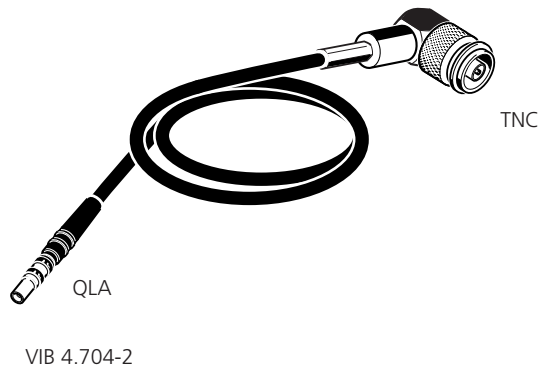

A

### Application

Standard sensor cable for connecting mobile CLD-type accelerometers to the VIBROTIP data collector.

### Cable length

VIB 4.70x-2 /-5 2 m / 5 m

VIB 321926-2 0.4 ... 2.0 m

### Accessories

VIB 8.617 QLA angled plug for VIBROTIP

### Connection example

VIBCODE to VIBROTIP

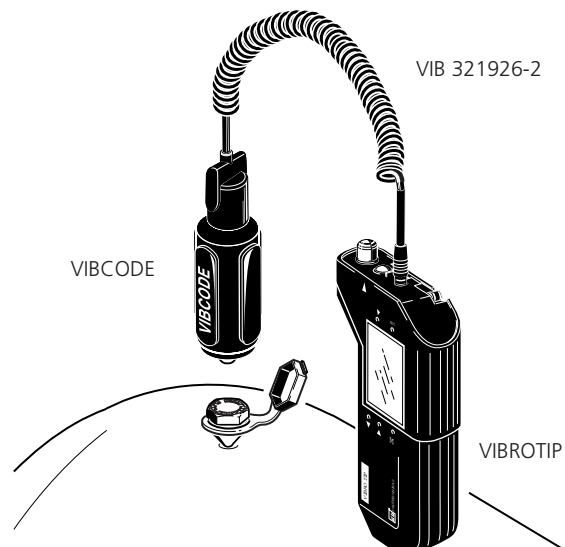

## TIPTECTOR cables (VIBROTIP)

VIB 8.618-1,5 : TIPTECTOR cable, straight, 1.5 meters (VIBROTIP)

VIB 8.618-5 : TIPTECTOR cable, straight, 5 meters (VIBROTIP)

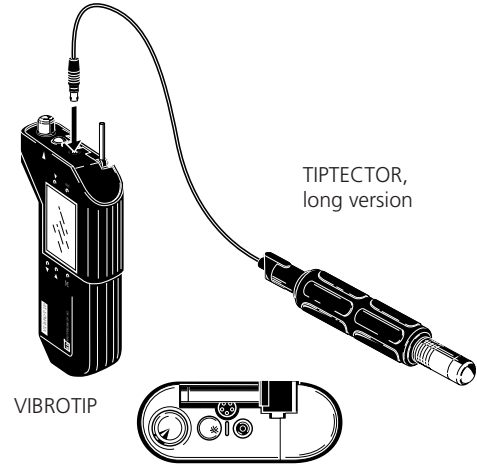
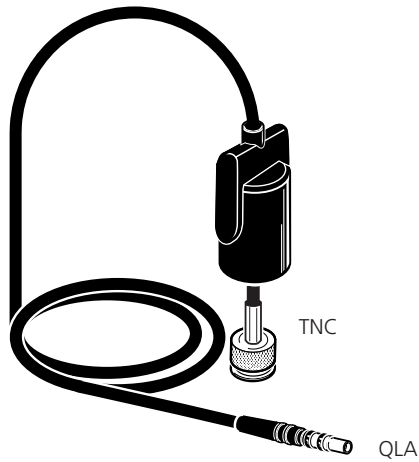

### Application

Spare connection cable for the TIPTECTOR probe.

### Note

To disconnect the cable, first pull off the cap, and, with the long version, unscrew the handle. Then unscrew the TNC connector.

### Connection example

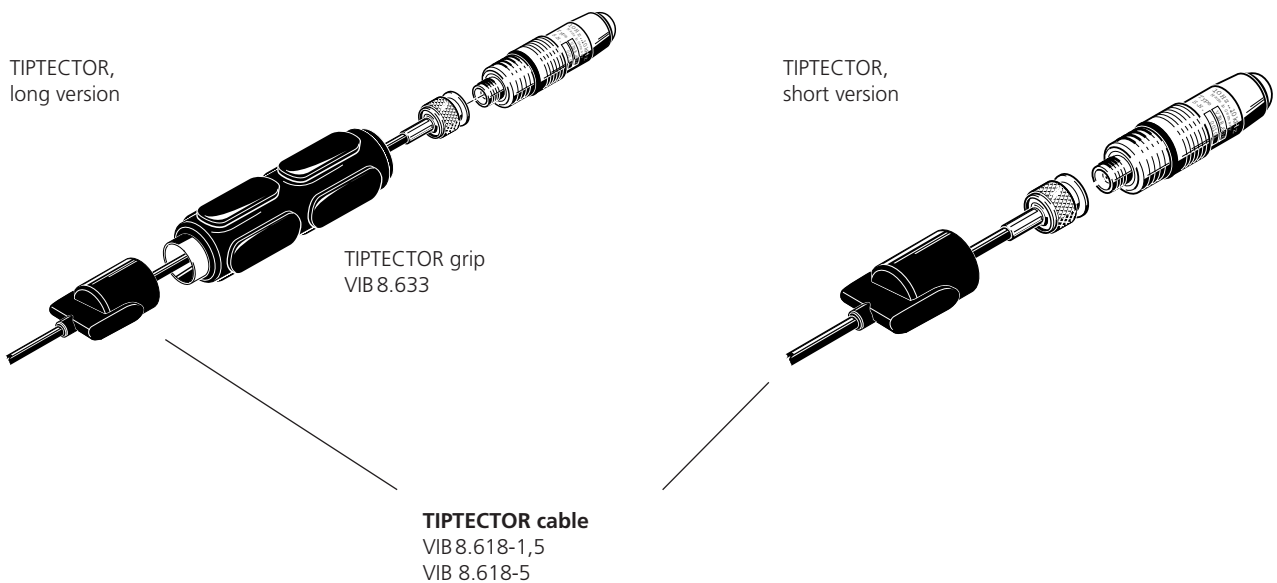

C

## Connection cables for ICP-type accelerometers (VIBSCANNER / VIBXPART)

1

VIB 5.438-0.5 : Straight connection cable for ICP-type accelerometer, 0.5 m, BNC-connector (VIBSCANNER/ VIBXPART)

VIB 5.422 : Spiral connection cable for ICP-type accelerometer, MIL-connector (VIBSCANNER / VIBXPART)

VIB 5.345-6 : Cable extension for VIB 5.422, 6 meters, MIL-connector (VIBSCANNER / VIBXPART)

2

MiniSnap



VIB 5.438-0.5

3

4

MiniSnap



VIB 5.422

5

MIL-C-5015



VIB 5.345-6

6

A

### Application

Standard sensor cable for connecting an ICP-type accelerometer or a microphone to the following data collectors:

- VIBXPART II
- VIBXPART I
- VIBXPART EX\*
- VIBSCANNER

### Notes

The intrinsically safe PRÜFTECHNIK ICP-type accelerometer VIB 6.172 XICP can be connected to VIBXPART EX using the cable VIB 5.422, and be operated in gas hazardous area.

### Cable lengths

VIB 5.438-0.5	0.5 m
VIB 5.422	0.7 ... 1.8 m
VIB 5.345-6	6 m

### Connection example

ICP to VIBXPART II

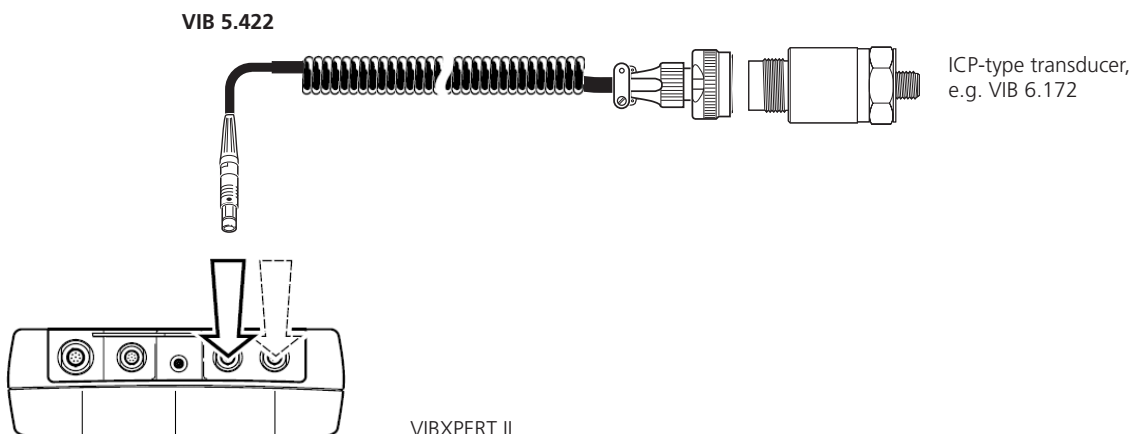



## Cable adapters for the measurement of signal-low voltage / current with VIBXPART II

- VIB 5.433 : Cable adapter for the measurement of signal-low voltage with VIBXPART II / VIBSCANNER
- VIB 5.434 : Cable adapter for the measurement of signal-low current with VIBXPART II / VIBSCANNER



### Application

These cable adapters are used to measure signal-low voltage (AC: 0-30V) or signal levels (DC: 0-30V; 0-30 mA) provided by other measuring instruments.

An additional cable with at least one BNC plug is required to connect the adapter cable to the signal-measuring instrument.

### Safety notes

The cable adapters may not be used in hazardous areas!  
 All electric circuits in VIBXPART II are galvanically connected. If more than one electric circuit is connected, a difference in potential may result in malfunctions.

The length of the spiral cable is 0.7 to 1.8 meters.

### Application example

Measuring shaft vibration via machine protection system (e.g. Bently Nevada 3300) as voltage signal

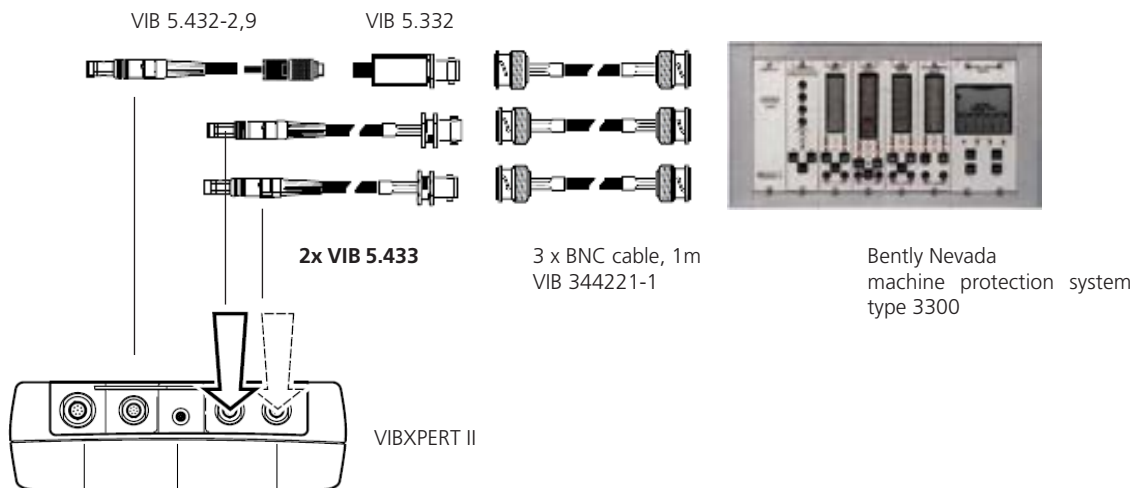

C

1

2

3

4

5

6

A

**Application examples**

- Connection to pressure transmitter: Pressure as a current level (4-20mA)
- Connection to continuous flow measuring instrument: Throughput as a current or voltage level (4-20mA / 0-10V)

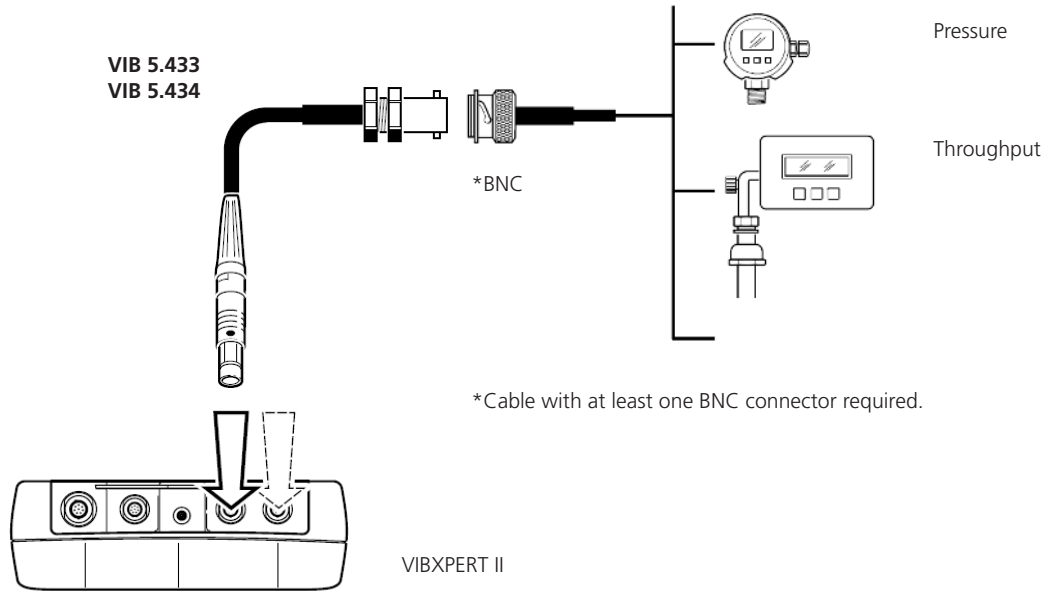

# VIB 5.433 X : Cable adapter for the measurement of signal-low voltage with VIBXPERT EX / VIBSCANNER EX



### Application

This cable adapter is used to measure signal-low voltage (AC/DC: 0-30V) provided by other measuring instruments.

An additional cable with at least one BNC plug is required to connect the adapter cable to the signal-measuring instrument (see example on next page).

### Safety notes

The cable adapter may not be used in hazardous areas!

The cable adapter protects the analog port of the data collector (VIBXPERT EX / VIBSCANNER EX) against surges. The adapter must be connected with the data collector only outside the hazardous area to an electrical circuit, whose maximum voltage does not exceed 265 V<sub>rms</sub>, when a malfunction occurs.

### Technical data

PARAMETER		VIB 5.433 X
General	Cable length	0.7 ... 1.8 m
	Temperature range	0°C ... + 40°C
	Maximum measurement error	-2,0% / +2,7%
	Upper frequency for AC measurements	5 kHz

### Application example

Measuring shaft vibration via machine protection system (e.g. Bently Nevada 3300) as voltage signal

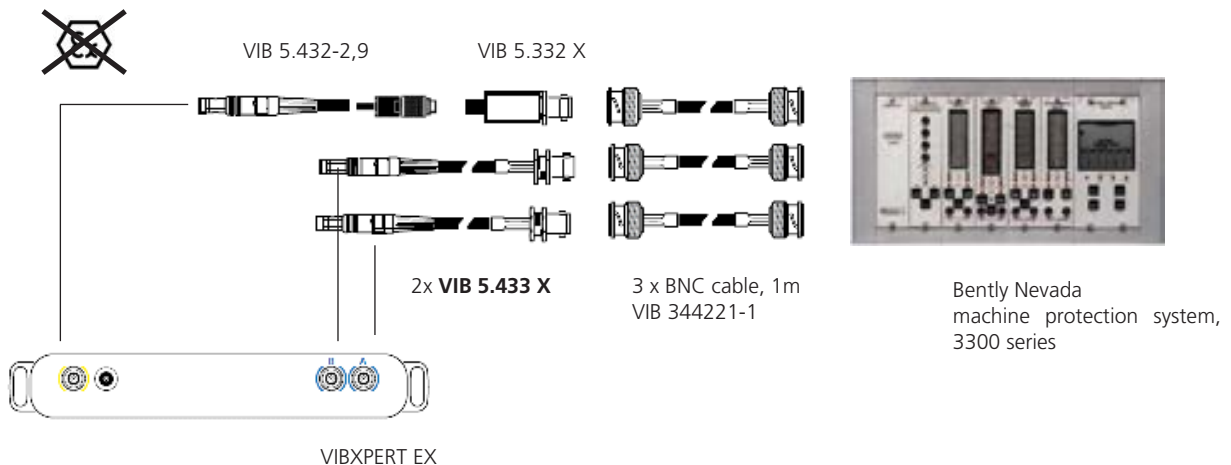

- C
- 1
- 2
- 3
- 4
- 5**
- 6
- A

**Application example**

Pressure / Throughput as a voltage level (0-10V)



VIB 5.433 X

\*BNC

Pressure

Throughput

Etc.

\*Cable with at least one BNC connector required.



VIBXPERT EX

## Connection cables for RPM sensors and trigger sensors (VIBSCANNER / VIBXPert)

VIB 5.432-2,9 : Connection cable for RPM sensors (VIBSCANNER / VIBXPert)

VIB 4.750-5 : Cable extension for VIB 5.432-2,9

VIB 5.443 : Connection cable for TTL trigger sensors (VIBSCANNER / VIBXPert)

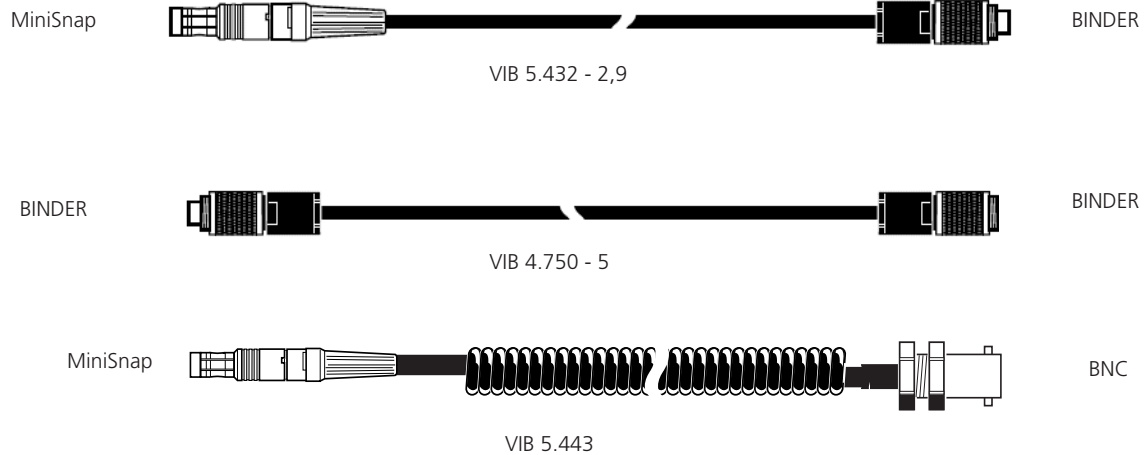

### Application

The VIB 5.432-2,9 cable is used to connect the PRÜFTECHNIK RPM sensors VIB 6.631 or VIB 6.631 EX to the following data collectors:

- VIBXPert II
- VIBXPert I
- VIBXPert EX
- VIBSCANNER
- VIBSCANNER EX

The VIB 5.443 cable is used to connect a trigger sensor from other manufacturers.

#### Cable lengths

VIB 5.432-2,9	2.5 m
VIB 4.750-5	5.0 m
VIB 5.443	0.45 - 1.6 m

### Application example



C

**VIB 5.431 : Cable for analog signal output ( VIBSCANNER / VIBXPERT )**

1

2

3

4



5

**Application**

In order to analyze the measured analog signal, a head-set (> 450 Ohm) or an analytical instrument (e.g. oscilloscope) can be connected with this cable to the following data collectors:

6

- VIBXPERT II
- VIBXPERT I
- VIBXPERT EX
- VIBSCANNER
- VIBSCANNER EX

A

Cable length: 0.7 to 1.8 meters

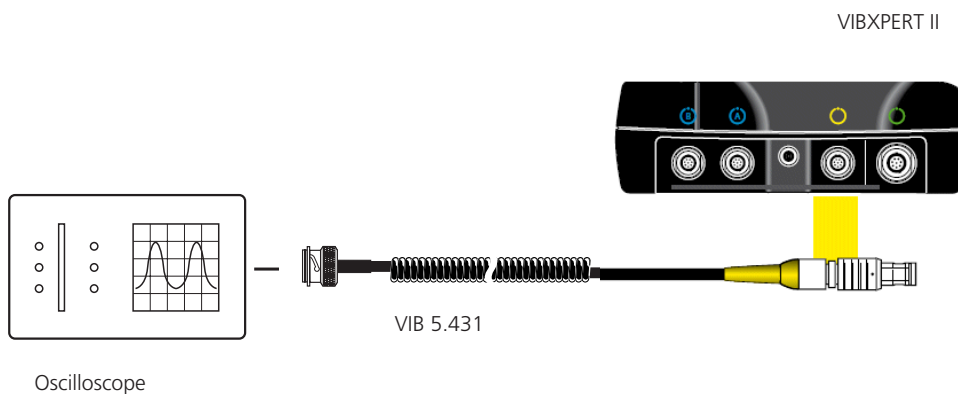
**Application example**

## VIB 5.332 : Keyphasor adapter for machine protection systems (VIBSCANNER / VIBXPERT)



### Application

This adapter converts a pulse signal (including the DC level) to a 5V rectangular signal. Keyphasor signals can thereby be measured at a machine protection system output with PRÜFTECHNIK instruments:

- VIBXPERT II
- VIBXPERT I
- VIBSCANNER

### Technical data

PARAMETER		VIB 5.332
Electrical	Operating voltage	5.4 V ± 10%
	Power consumption	0.5 mA
	Input signal, Pulse width	> 100 µs
	- , Pulse level	> 500 mV <sub>pp</sub>
	- , DC fraction	+8 V to -30 V
	Output signal	5 V, rectangular signal
	Input resistance	200 kOhm
Mechanical	Output resistance	1 kOhm
	Housing material	Stainless steel, VA 1.4301
	Length, incl. connectors	130 mm
	Diameter	15 mm
	Weight	30 g
	Env. protection class	IP 65
	Temperature range	0°C ... +60°C
Interfaces	Input signal	Binder connector, 8 pin, 712 series
	- , Pin allocation	2 / 5V, 4 / rectangular signal, 7 / GND
	Output signal	BNC connector
- , Pin allocation	internal contact / signal, external contact / GND	

### Connection

On the instrument side, the adapter is equipped with an 8-pin binder socket that is connected to trigger cable VIB 5.432-2,9. The signal input side provides a BNC socket.

### Application example

VIBXPERT II connected to Bently Nevada 3300 series

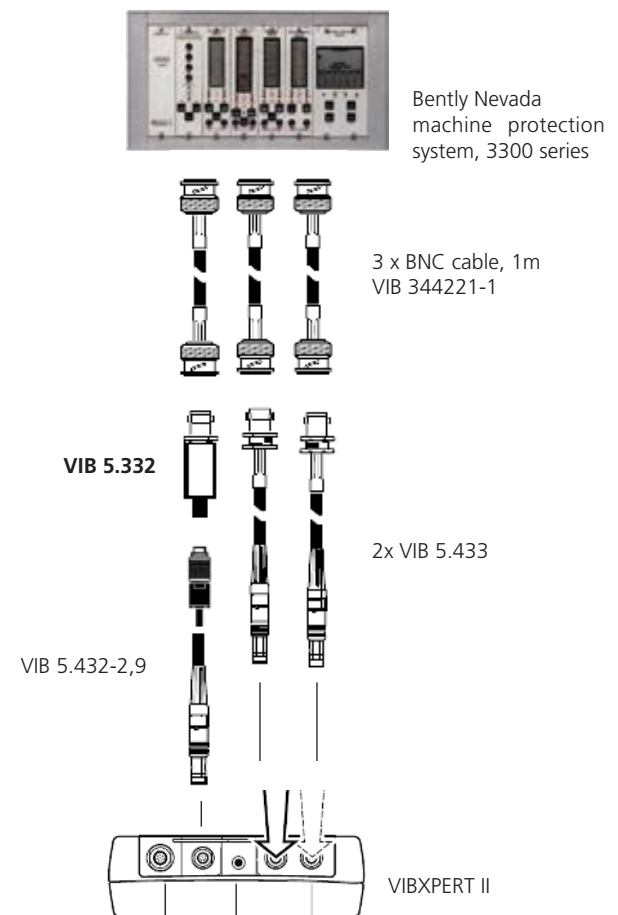

C

## VIB 5.332 X : Keyphasor adapter for machine protection systems (VIBSCANNER EX / VIBXPERT EX)

1

2



3



4

### Application

This adapter converts a pulse signal (including the DC level) to a 5V rectangular signal. Keyphasor signals can thereby be measured at a machine protection system output with PRÜFTECHNIK instruments:

5

- VIBXPERT EX
- VIBSCANNER EX

6

### Connection

On the instrument side, the adapter is equipped with an 8-pin binder socket that is connected to trigger cable VIB 5.432-2,9. The signal input side provides a BNC socket.

A

### Technical data

PARAMETER		VIB 5.332 X
Electrical	Operating voltage	5.4 V ± 10%
	Power consumption	0.5 mA
	Input signal, Pulse width	> 100 µs
	- , Pulse level	> 500 mV <sub>pp</sub>
	- , DC fraction	+8 V to -30 V
	Output signal	5 V, rectangular signal
	Input resistance	200 kOhm
	Output resistance	1 kOhm
Mechanical	Housing material	Stainless steel, VA 1.4301
	Length, incl. connectors	130 mm
	Diameter	15 mm
	Weight	30 g
	Env. protection class	IP 65
	Temperature range	0°C ... +40°C
Interfaces	Input signal	Binder connector, 8 pin, 712 series
	- , Pin allocation	2 / 5V, 4 / rectangular signal, 7 / GND
	Output signal	BNC connector
	- , Pin allocation	internal contact / signal, external contact / GND

### Safety notes

The adapter may not be used in hazardous areas!

The adapter protects the digital port of the VIBXPERT EX against surges. The adapter must be connected with VIBXPERT EX only outside the hazardous area to an electrical circuit, whose maximum voltage does not exceed 265 V<sub>rms</sub> when a malfunction occurs.

Ambient temperature: 0°C to + 40°C.

### Application example

VIBXPERT EX connected to Bently Nevada 3300 series



Bently Nevada machine protection system, 3300 series

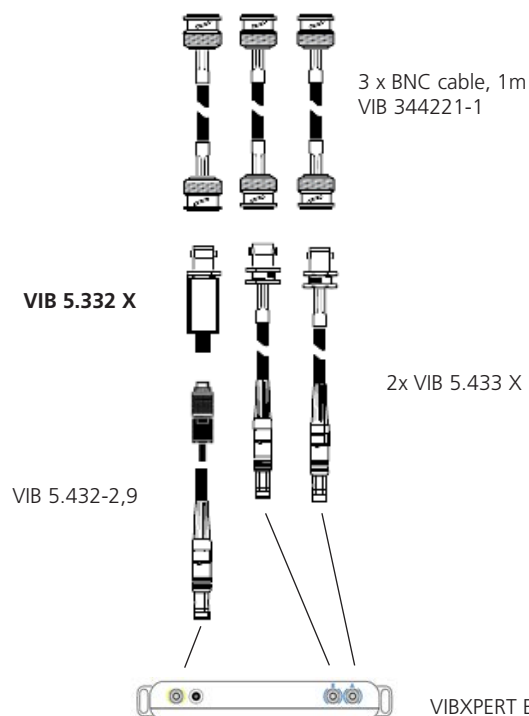



## VIB 5.333 : Cable adapter for TTL / strobe output (VIBXPRT)



### Application

The VIB 5.333 cable adapter is used to connect a stroboscope to VIBXPRT. The flash rate is controlled by the cursor on the spectrum.

### Connection

BNC: Stroboscope trigger input with BNC cable.

Binder: VIBXPRT digital input with cable VIB 5.432-2,9.

### Technical data

PARAMETER		VIB 5.333
Mechanical	Housing material	Aluminium
	Length, incl. connectors	62 mm
	Diameter	15 mm
	Weight	20 g

### Application example

VIBXPRT II connected to stroboscope

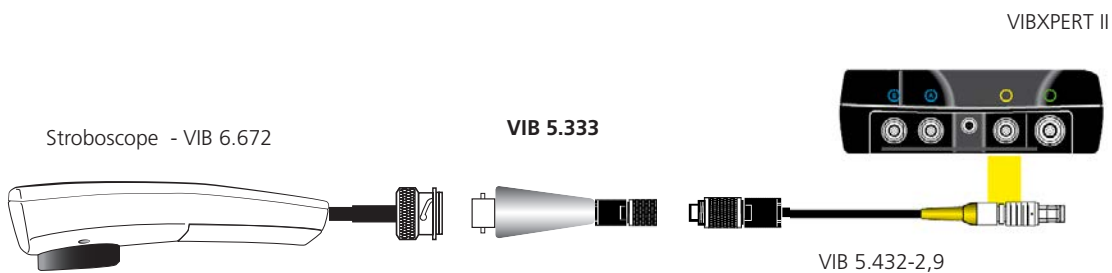

C

## VIB 5.336 : Cable adapter for triaxial accelerometer (VIBXPERT)

1

2

Mini-MIL,  
4-pin



MiniSnap

3

4

### Application

The cable adapter VIB 5.336 is used to connect the triaxial accelerometer VIB 6.655 to the VIBXPERT II instrument. It is not permissible to connect the triaxial accelerometer to VIBXPERT EX.

5

### Connectors

MiniSnap: Analog inputs A & B  
MiniMIL: Triaxial sensor VIB 6.655

6

A

### Technical data

PARAMETER		VIB 5.336
Design	Conductor	4-pin AWG25, spiralized CTC cable from adapter to sensor
	Cable sheath	PU
	Diameter	5.3 mm
	Cable length, instrument side	approx. 0.4 m
	-, sensor side	approx. 2.6 m
Environment	Operation temperature range	-10 °C ... +60 °C
	Storage temperature range	-20 °C ... +80 °C
	Rel. humidity	< 95 %
	Env. protection	IP 65
	Weight	approx. 310 g

### Application example

VIBXPERT II connected to triaxial accelerometer VIB 6.655

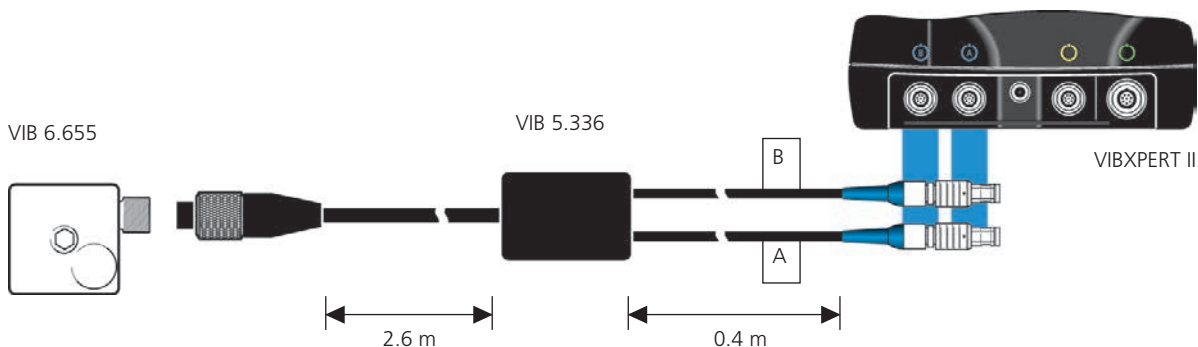

## Adapters and cables for voltage-supplied sensors and VIBROTECTOR (VIBXPRT)

VIB 5.341 :	VST 24V adapter for VIBXPRT II
VIB 5.342 :	Analog cable for VST 24V adapter
VIB 5.343 :	Digital cable for VST 24V adapter
VIB 5.344 :	VIBROTECTOR cable for VST 24V adapter

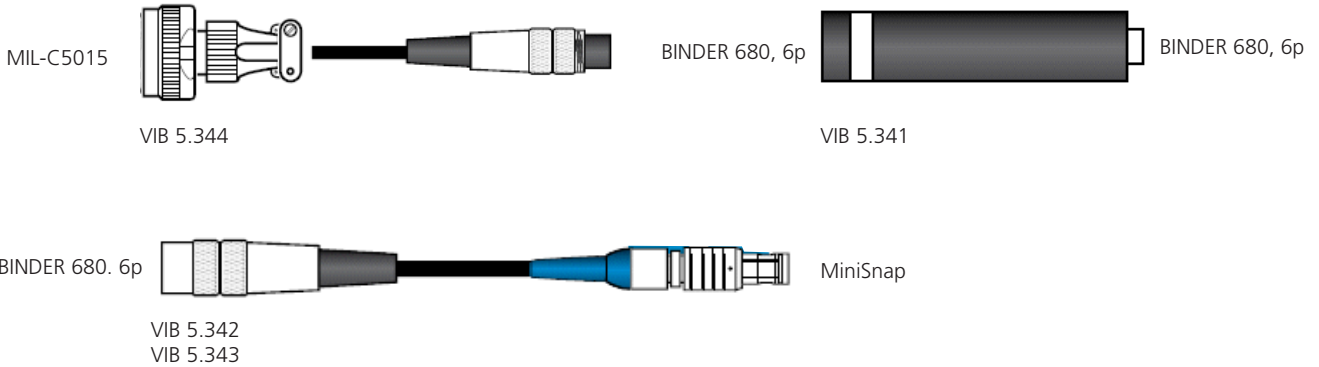

### Application

The VST 24V adapter is used for connecting any sensors with a power supply (-24 VDC) to the VIBXPRT II instrument.

Examples of sensors:

- AS-022: accelerometer
- IN 085: non-contacting displacement sensor from Brüel & Kjaer Vibro / Schenck Vibro.
- VIBROTECTOR: vibration transmitter from PRÜFTECHNIK Condition Monitoring

To measure RPM, sensors with a power supply (-24 VDC) or rpm reference sensors with an external supply can be connected. The minimum required trigger level is 2 volts.

### Safety note

Do not operate VIBXPRT II with the charger unit when the adapter is connected.

### Cleaning notes

- Clean with a moist cloth.
- Use a mild detergent or alcohol.

### Technical data

PARAMETER		VIB 5.341
Electrical	Output voltage $U_{out}$	-24V, unregulated (dep. on VIBXPRT)
	Frequency range, Signal IN - Analog Out Signal IN - Trigger Out	0.1 Hz ... 100 kHz
	Case material	stainless steel + heat shrink tubing
Mechanical	Plug	DIN 41524, BINDER 680, 6 pole, m / f
	Dimensions L x D	120 x 27 mm
	Weight	105 g
	Protection class	IP 40
	Temperature range	-10°C ... +60°C

### Connection

The VST 24V adapter is connected to the sensor and instrument using the cables provided:

Analog cable - VIB 5.342:

Connection cable between adapter and VIBXPRT II for measurement of vibration acceleration, velocity and displacement.

Digital cable - VIB 5.343:

Connection cable between adapter and VIBXPRT II for RPM measurement.

VIBROTECTOR cable - VIB 5.344:

Connection cable between adapter and VIBROTECTOR vibration transmitter. The adapter is connected to VIBXPRT II with the analog cable (VIB 5.342).

Cable length: 2.9 meters

### Plug pin allocation, sensor side

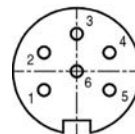

- 1: -24 VDC
- 2: Analog signal (Sensor)
- 3: Trigger signal (5V TTL)
- 4: GND
- 5: Shield
- 6: 5 VDC (Voltage from VIBXPRT)



C

### Connection examples

1

- Displacement measurement with IN 085 sensor
- Vibration measurement with VIBROTECTOR

2

3

4

5

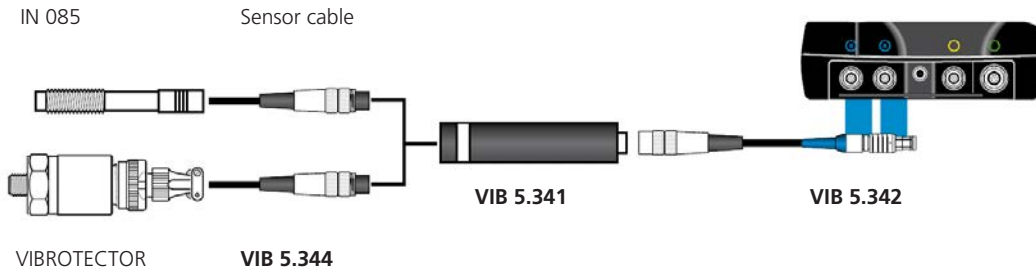

6

- RPM measurement with IN 085 sensor

A

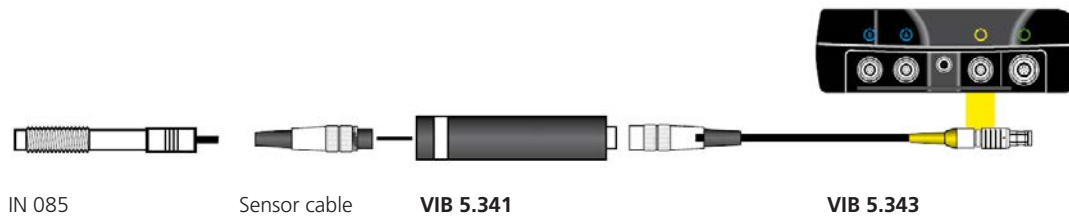

## VIB 5.439 : Connection cable for Pt100 temperature probe (VIBSCANNER)



### Application

This cable is used to connect a Pt100 temperature probe to VIBSCANNER for temperature measurements.

Cable length: 0.7 ... 1.8 meters

### Connection example

Pt100 probe connected to VIBSCANNER

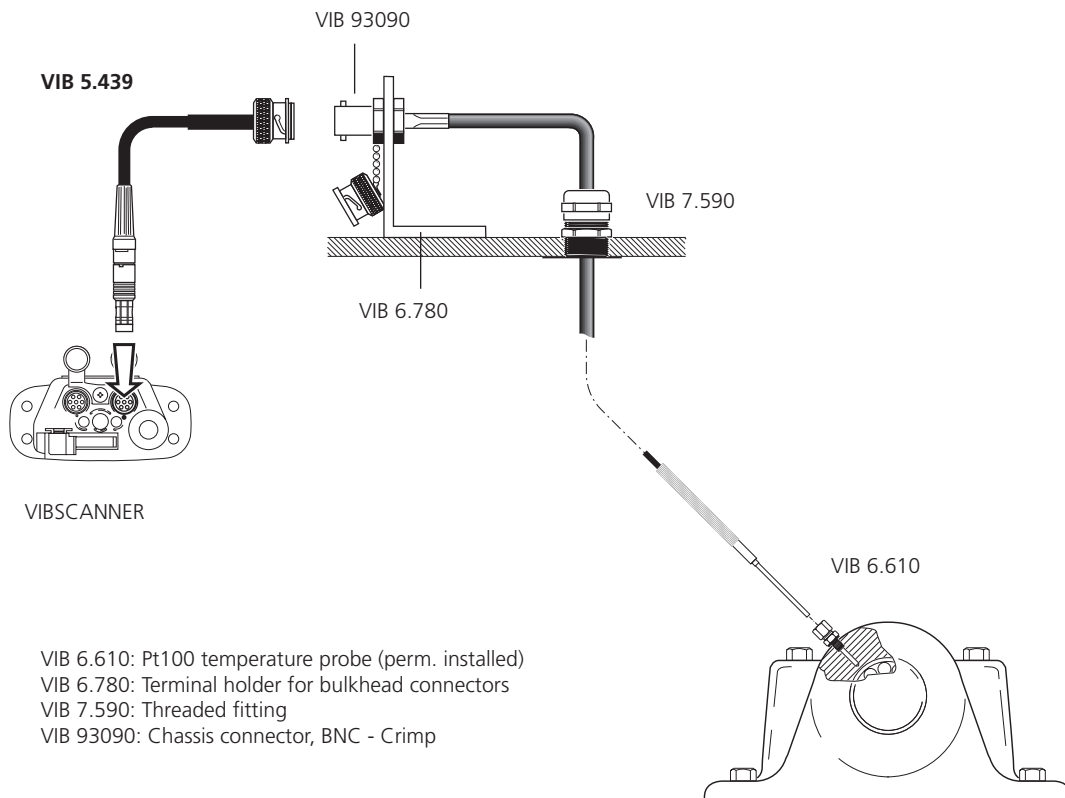

C

## VIBSCANNER channel switches

1

VIB 5.445 : Manual channel switch for 2-plane balancing with VIBSCANNER

VIB 5.446 : Automatic channel switch for 2-plane balancing with VIBSCANNER

2

3

4

5

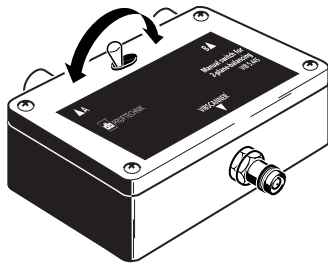

VIB 5.445

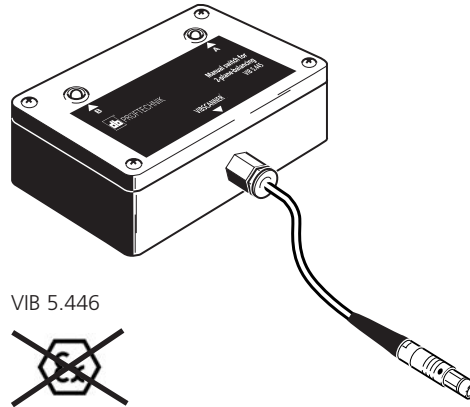

VIB 5.446

6

### Application and function

The channel switch provides two inputs for accelerometers, which are merged into one output channel. The channel switching is done either via a toggle switch (VIB 5.445) or automatically controlled by the VIBSCANNER application program (VIB 5.446).

This simplifies e.g. the (sequential) balancing in two planes, because the accelerometers do not have to be unplugged when changing the balancing plane.

### Connection

With the manual channel switch VIB 5.445, the accelerometers are connected each with a coaxial cable with TNC connector (VIB 311221-L). The channel switch itself

is plugged in VIBSCANNER with the connection cable for linedrive accelerometers VIB 5.436.

The automatic channel switch VIB 5.446 is connected directly to VIBSCANNER. For each sensor, a connection cable for linedrive accelerometers (VIB 5.436) is required.

### Note

The automatic switch cannot be operated with VIBSCANNER EX!

### Accessories

VIB 5.436 Conn. cable for linedrive accelerometers  
 VIB 311221-L Coaxial cable, TNC (2x), L= cable length

### Technical data

PARAMETER		VIB 5.445	VIB 5.446
Mechanical	Case material	Aluminium	
	Connections	1x TNC socket, 2x TNC socket	1x Cable with MiniSnap plug 2x MiniSnap sockets
	Dimensions L x B x H	97 x 63 x 35 mm	
	Weight	approx. 230 g	

### Application example

VIB 5.446 to VIBSCANNER



## VIB 8.749 : Current LineDrive converter for data collector with voltage input

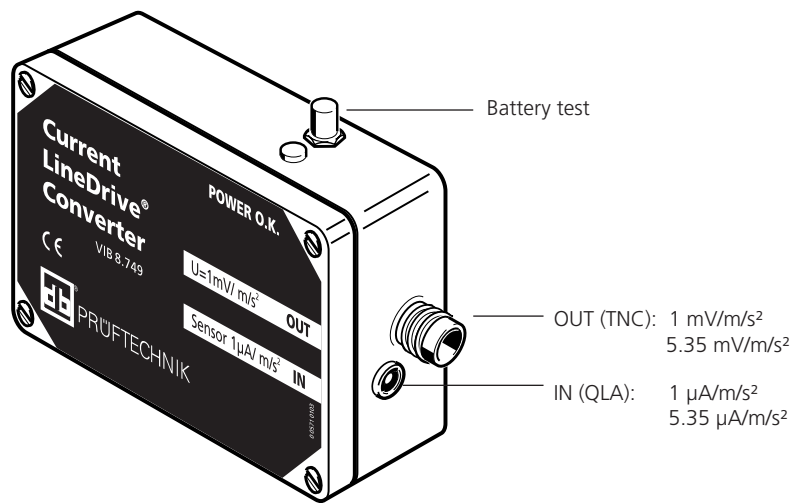

### Description

This adapter converts the current signal of a current line drive accelerometer into a voltage signal. Thus PRÜFTECHNIK accelerometers can be connected to data collectors with voltage input. The adapter is powered by two 9V batteries.

### Note

Battery condition can be checked at the press of a button: if the green LED lights up, the batteries are loaded.

### Connection

The accelerometer is connected to the adapter with a VI-BROTIP sensor cable (e.g. VIB 4.704-2). The data collector is plugged into the signal output socket using a suitable TNC cable.

### Technical data

PARAMETER		VIB 8.749
Electrical	Power requirement	2x 9 volt batteries (6LR61)
	Sensitivity	1 mV / 1 µA
	Accuracy	±1% of measured value
	Current consumption	6 mA (w/ sensor)
	Operating duration	approx. 75 hours
General	Dimensions, H x W x D	3.5 x 11 x 6 cm
	Env. protection	IP 50
	Temperature range	+10°C ...+40°C
	Weight, incl. batteries	approx. 320 g

C

## Cable adapters for accelerometers with Mil-type connector

1

VIB 5.449-CLD : Cable adapter for CLD-type accelerometer VIB 6.195

VIB 5.449-ICP : Cable adapter for ICP-type accelerometer VIB 6.172

2

3

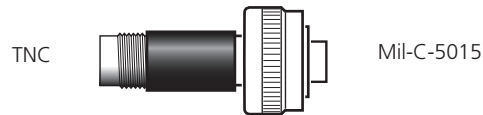

4

### Application

Connection of accelerometers with Mil-type connectors, e.g. VIB 6.195 (CLD type) or VIB 6.172 (ICP type) to the following PRÜFTECHNIK instruments:

5

- VIBXPERT II
- VIBGUARD portable
- VIBSCANNER

6

A

### Application example

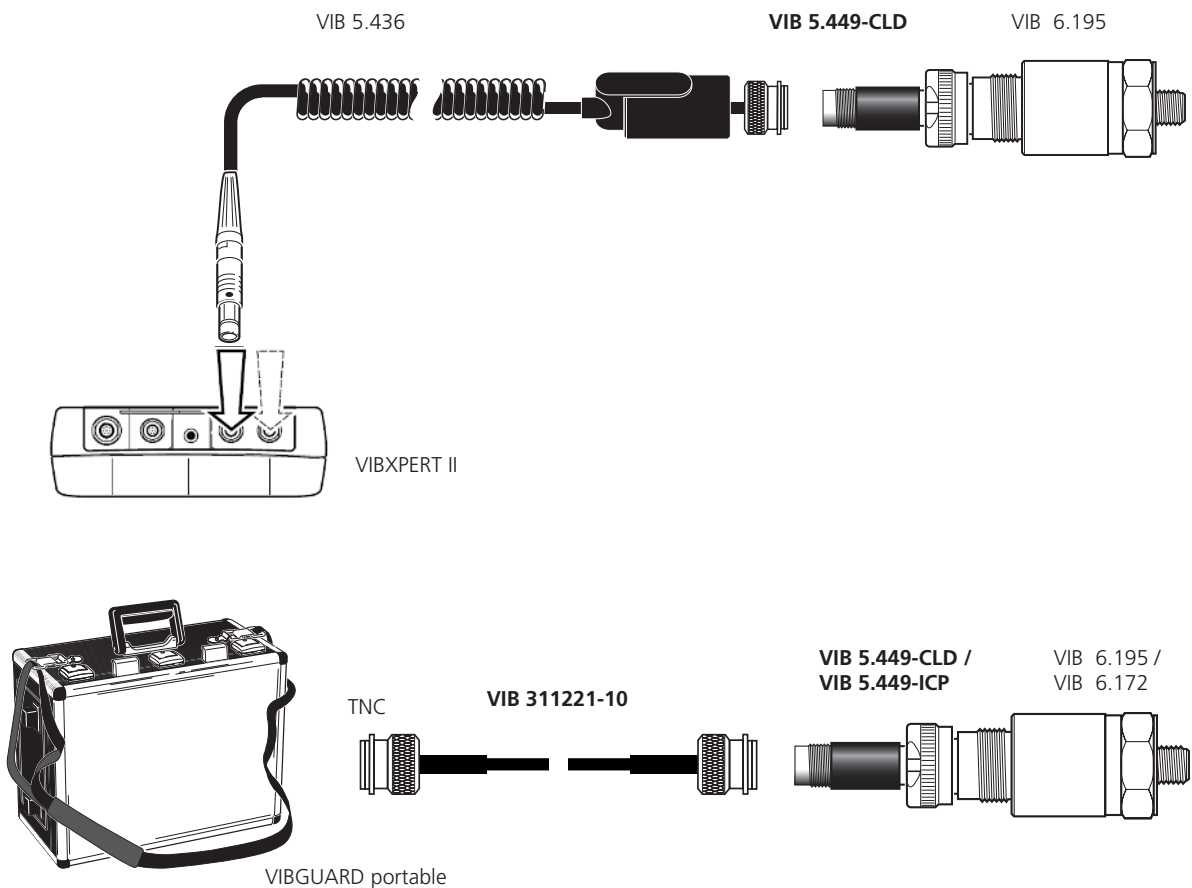



## Cable adapters for VIBROTIP

VIB 4.705 : BNC to QLA cable adapter

VIB 8.617 : QLA angled plug

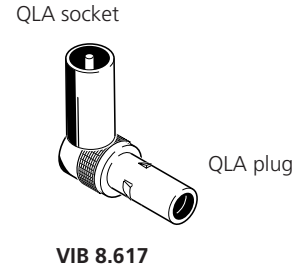
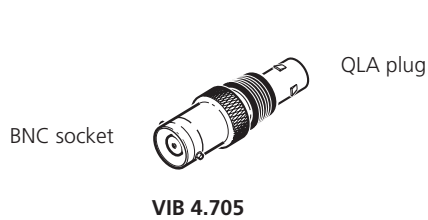

### Application

These adapters extend the connection options at the QLA input of the VIBROTIP data collector.

The VIB 4.705 adapter connects transducers with BNC connector to the data collector. The VIB 8.617 adapter is

used to connect external vibration sensors to VIBROTIP so that they do not interfere with measurements using the built-in temperature probe or RPM sensor.

Connection example  
VIB 8.617 to VIBROTIP and VIBCODE

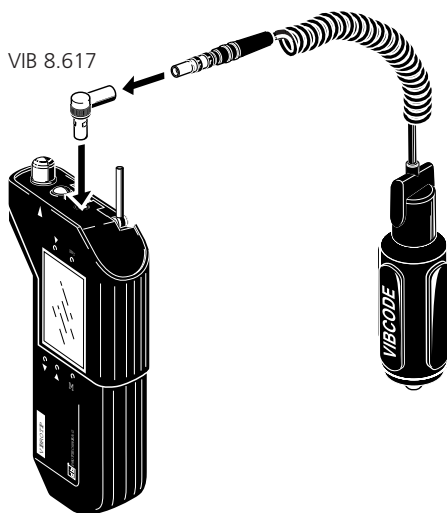

Connection example  
VIB 4.705 to VIBROTIP

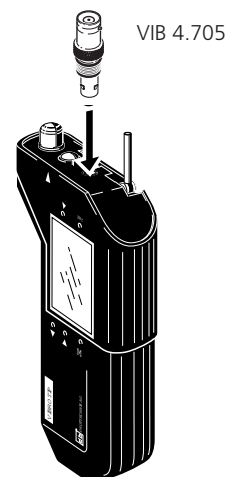

# C Terminal holder for bulkhead connectors

- 1 VIB 6.780 : Terminal holder for bulkhead connectors
- VIB 10473 : Dust cap for TNC connector

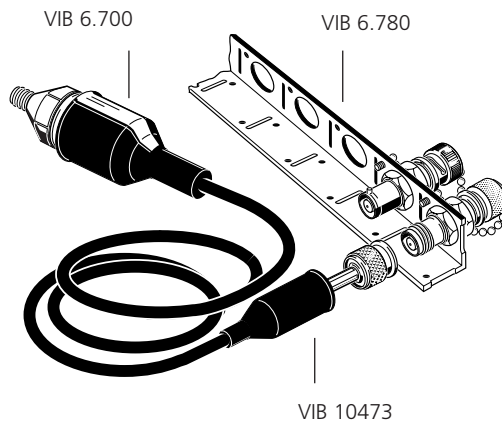
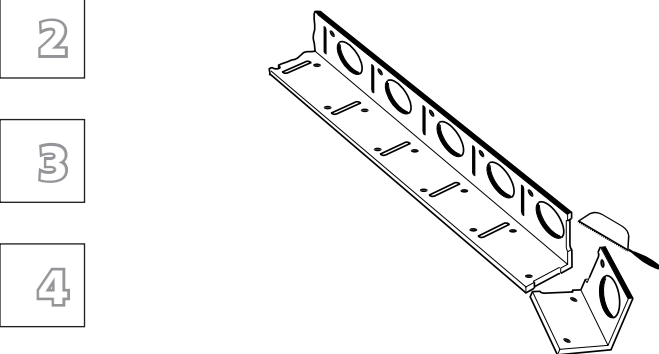

**Application**  
Up to 12 sensor cables are joined at the terminal holder to record the measured values conveniently with a data collector.

The cables are mounted on the terminal holder with the aid of bulkhead connectors. The terminal holder can be sawn to the required length.

The TNC dust cap VIB 10473 hermetically seals the connection between the sensor cable and the bulkhead connector.

**Note**  
To seal the connection between the accelerometer and the sensor cable a dust caps with a larger diameter is required (e.g. VIB 6.700).

### Technical data

PARAMETER		VIB 6.780	VIB 10473
General	Material	Plastic PA	Silicone (HTV R 701)
	Env. protection	---	IP 65
	Temperature range	0°C ...+85°C	< +200°C
	Chemical resistance	--	aliphatic hydrocarbons (mineral oils)

### Mounting hole

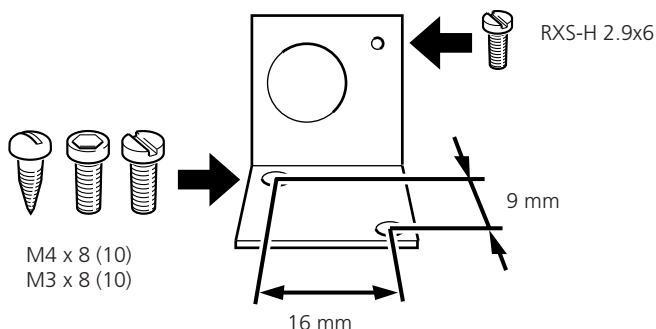

The screws are not included in the scope of delivery

### Mounting example

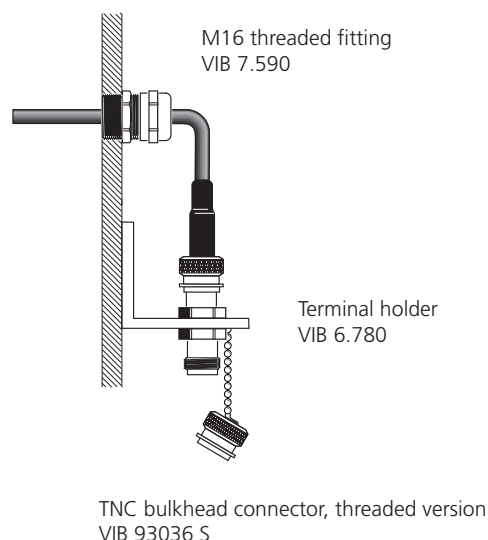

**Attention!**  
The bulkhead connector dust cap is attached to a metal cord. To electrically insulate the connector, the dust cap must only come into contact with insulated components.

## VIB 6.785 : SwitchBox - Channel switching unit for CLD-/ ICP-type accelerometers, 12 ch.

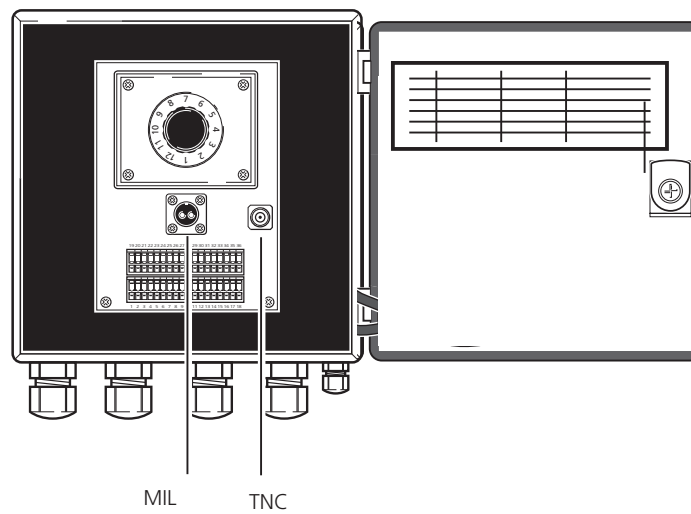

### Application

The SwitchBox channel switching unit VIB 6.785 has been designed to enable inaccessible measurement locations to be monitored and hard wired back to a safe position.

The channels are individually selected by a rotary switch. The data collector (e.g. VIBSCANNER or VIBXPERT) is connected to one of the two sockets (TNC/MIL) using an appropriate cable.

### Installation

The SwitchBox requires no external power supply. Up to 12 accelerometers can be connected to the SwitchBox. All accelerometer cables are glanded into the SwitchBox, terminations are made off into spring terminals. The VIB 81060 screwdriver is included in the scope of delivery for the installation of the accelerometer cables.

As of version 1.1 the SwitchBox can also be installed in hazardous areas.

### Accessories

VIB 5.436 Spiral cable for Linedrive accelerometer, TNC  
 VIB 5.422 Cable for ICP-type accelerometer, MIL

### Technical data

PARAMETER		VIB 6.785
General	Input	Up to 12 accelerometers (ICP or LineDrive)
	Output	one via TNC or MIL socket
	Temperature range	- 20°C ... + 60°C
	Env. protection	IP 65

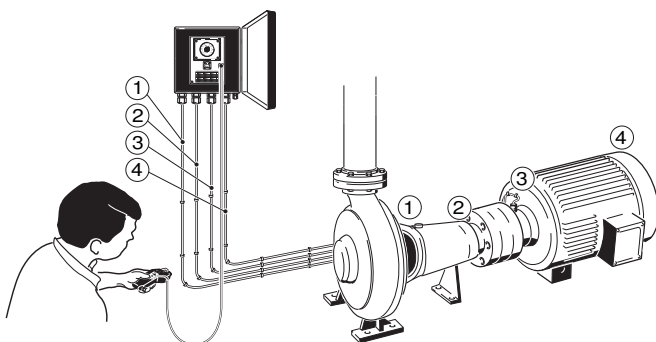

### Dimensions

in mm

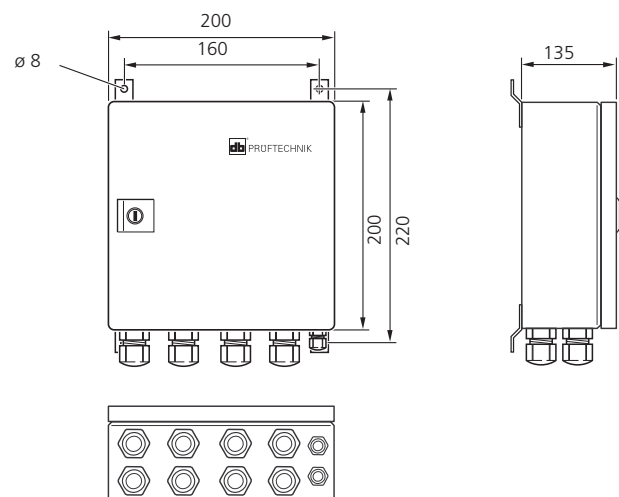

C

# SPM cable adapter for data collectors

1

- VIB 8.746-VD : SPM cable adapter for VIBROTIP
- VIB 8.746-VS : SPM cable adapter for VIBSCANNER / VIBXPERT

2

3

4

5

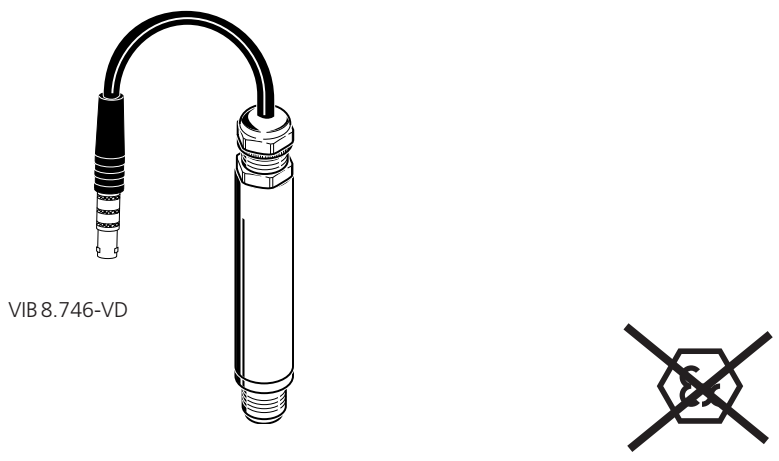

6

**Application**

The SPM cable adapter is used to connect PRÜFTECHNIK data collectors to existing SPM 40000 or TRA 30 measurement sensors by converting the voltage signal to a current signal.

A

**Note**

The SPM cable adapter may not be used in hazardous areas!

**Technical data**

PARAMETER		VIB 8.746-VD	VIB 8.746-VS
General	Input	QLA	MiniSnap
	Output	TNC	
	Length	approx. 240 mm	
	Diameter	16 mm	

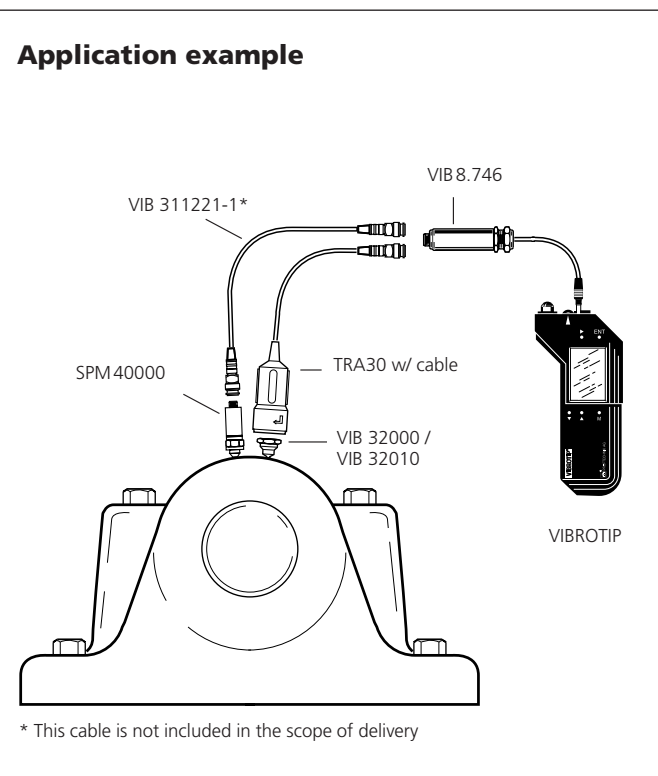

## VIBXPert II connection cable and adapter for VIBRONET field multiplexer

VIB 5.346: Connection cable, VIBXPert II to VIBRONET field multiplexer

VIB 5.346-MUX : BNC connection adapter for cable VIB 5.436

MiniSnap



BNC

VIB 5.346



VIB 5.346-MUX

### Application

These cables are used to connect the VIBXPert II data collector to a VIBRONET field multiplexer (VIB 8.306) for automatic data acquisition at many measurement locations of the same type or hard-to-access measurement locations.

The measurement locations are combined on one string line and are measured consecutively.

### Notes

Only vibration measurements with Current Linedrive accelerometers are possible.

Up to 6 multiplexers with a maximum of 54 measurement locations are possible on one string line.

It is not permissible to connect these cables to VIBXPert EX!

Cable lengths

VIB 5.346 1.5 meters

VIB 5.346-MUX 0.16 meters

### Application example



C

1

2

3

4

**5**

6

A

# Chapter 6

## Communication cables

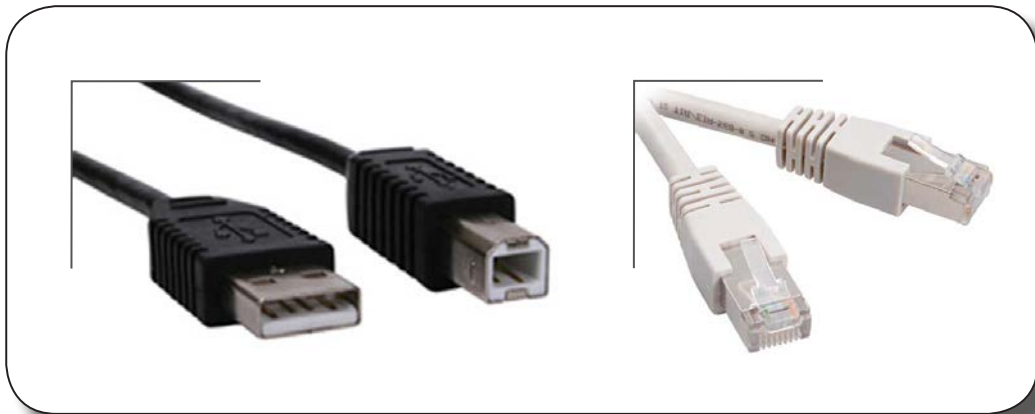

C

## Contents: Communication cables

1

2

3

4

5

6

A

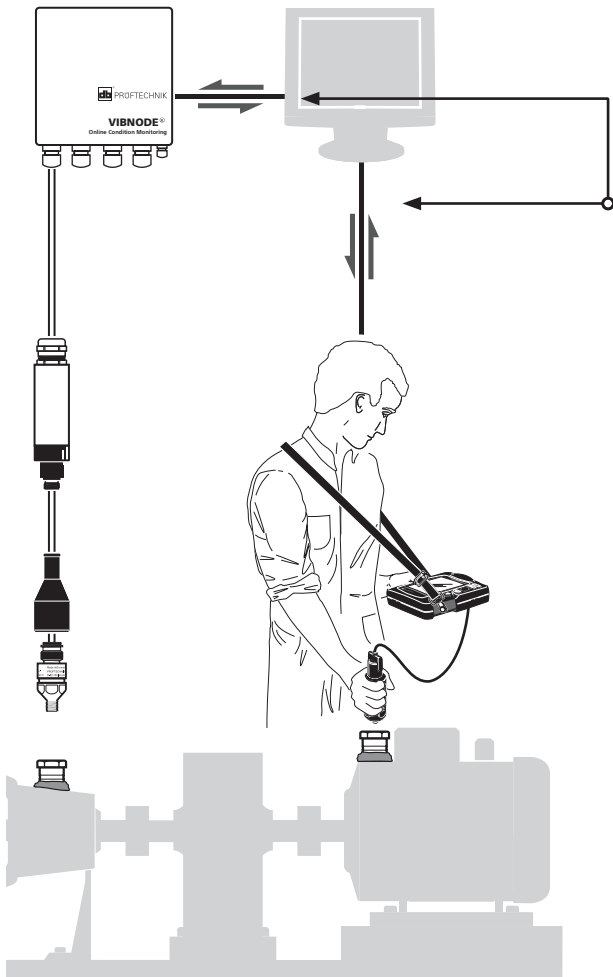

Order no.	Description	Page
VIB 5.330 MUSB VIB 5.330 SUSB VIB 5.330 MEM VIB 5.330-USB	VIBXPERT USB cable for periph. devices VIBXPERT USB cable for PC VIBXPERT II adapter for USB pen drive VIBXPERT II USB pen drive	177
VIB 5.330-UNV	Universal communication adapter for VIBXPERT EX	178
VIB 5.331	Ethernet cable, VIBXPERT	180
VIB 5.338	USB cable, VIBXPERT EX	178
VIB 5.430-2 VIB 5.448	Serial PC cable, VIBSCANNER / VIBXPERT Adapter cable, serial to USB, VIBSCANNER / VIBXPERT	181
VIB 5.955-X VIB 5.957-2 /-5	Patch cable, VIBRONET / VIBROWEB Crossover ethernet cable, VIBRONET / VIBROWEB	183
VIB 5.956-X	System bus cable, VIBRONET	184
VIB 8.619	Serial PC cable, VIBROTIP	181
VIB 8.619-USB	Serial to USB cable adapter, VIBROTIP EX	182



## VIBXPERT II USB cables and adapters

VIB 5.330 MUSB : VIBXPERT II USB cable for peripheral devices (Master)

VIB 5.330 SUSB : VIBXPERT II USB cable for communication (Slave)

VIB 5.330 MEM : VIBXPERT II adapter for USB pen drive

VIB 5.330-USB : VIBXPERT II USB pen drive

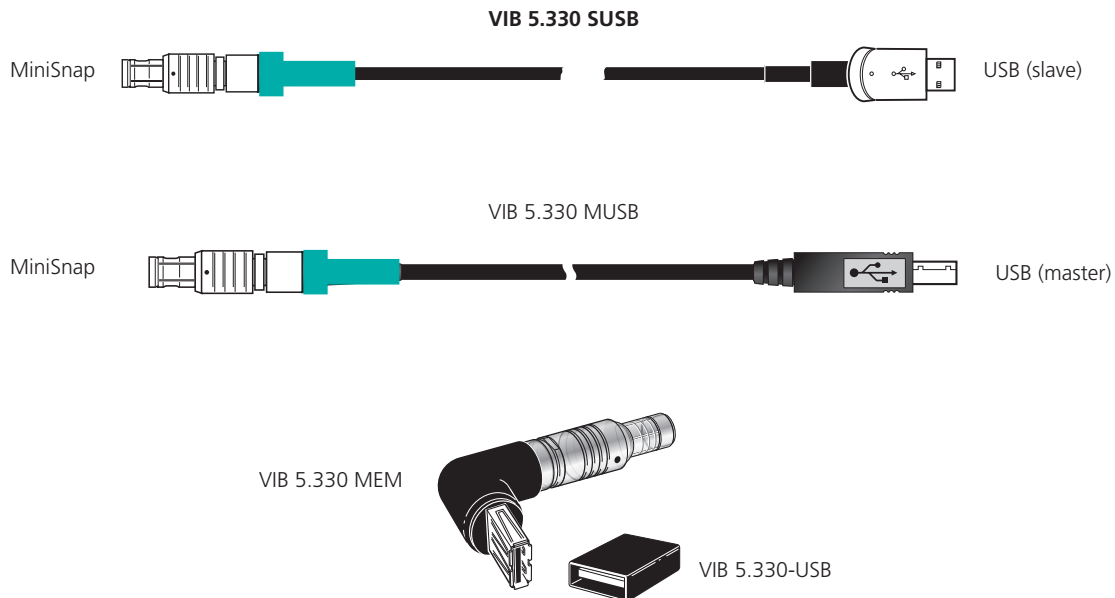

### Application

VIBXPERT II has a USB interface which can be used for communication and data transfer with a computer as well as for printing reports on a printer.

The cable for peripheral devices VIB 5.330 MUSB is used for connecting the printer. The connection to the PC is made with the cable VIB 5.330 SUSB. The adapter VIB 5.330-MEM is used to store reports in PDF format on the VIBXPERT II USB pen drive VIB 5.330-USB.

Cable lengths: 2 meters

### Note

These cables and the adapter may not be used with VIBXPERT EX!

### Application examples

Data transfer via USB



C

## Communication adapter and USB cable for VIBXPert EX

1

VIB 5.330 UNV : Universal communication adapter for VIBXPert EX

VIB 5.338 : USB cable for VIBXPert EX

2

### VIB 5.330-UNV

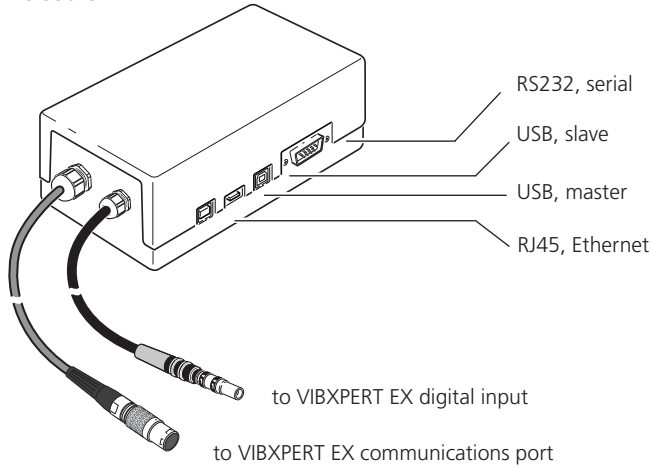

3

4

5

6

A

### VIB 5.338



### Application

The VIB 5.330-UNV adapter is a communication and printer interface for VIBXPert EX. The adapter protects the instrument against damage due to over voltages that may arise from connecting non-certified peripheral equipment.

### Connection

The adapter is connected to VIBXPert EX using the integrated cables. The connectors are color-coded to match the instrument sockets.

The adapter is connected to the PC via the serial or USB (slave) interface. An RJ45 socket is provided for the net-

work connection. To print out reports from VIBXPert EX, the adapter must be connected to a suitable printer via USB (master) and to a running PC via USB (slave) in order to operate the printer.

Cable length, VIB 5.338: 2 meters

### Note

The adapter may not be used in hazardous environments! The adapter can also be operated with standard VIBXPert (non-EX version).

### Technical data

PARAMETER		VIB 5.330-UNV
Interfaces	VIBXPert side	Two integrated connecting cables for digital and communications port
	PC	RS 232 and USB (slave)
	Printer	USB (master)
	Network	RJ 45
General	Case material	Plastic - Polystyrol
	Dimensions, L x B x H	170 x 80 x 55 mm
	Weight	approx. 350 g

**Application example**

VIB 5.330-UNV connected to VIBXPERT EX

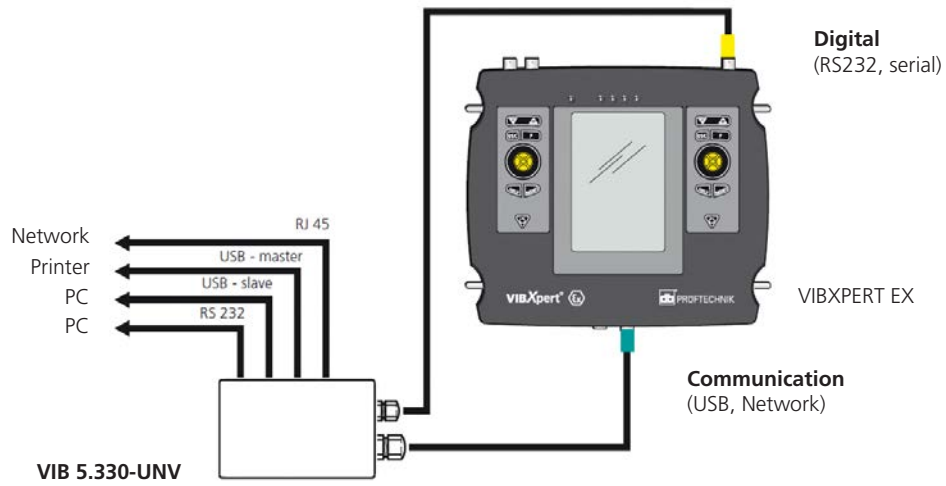
**Application example**

PC connected to VIBXPERT EX

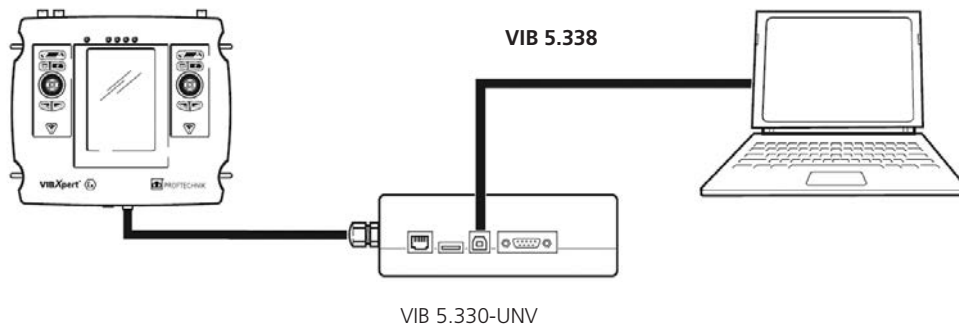

C

### VIB 5.331: VIBXPERT II Ethernet cable

1

2



3

4

#### Application

The VIBXPERT II is connected with the cable VIB 5.331 to an ethernet network to a hub or to a PC for data transmission.

5

Cable length: 2 meters

6

#### Note

This cable may not be used with VIBXPERT EX!

A

#### Application examples

Data transfer via Ethernet

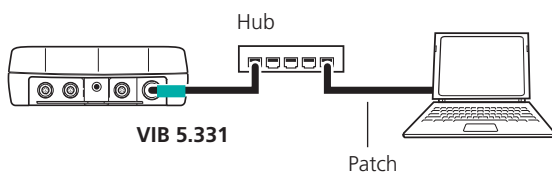
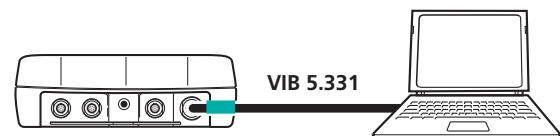
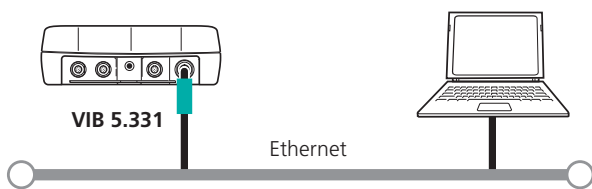

## Serial PC cables for VIBROTIP, VIBSCANNER and VIBXPRT

VIB 5.430-2 : Serial PC cable (VIBSCANNER / VIBXPRT)

VIB 5.448 : Adapter cable, serial to USB (VIBSCANNER / VIBXPRT)

VIB 8.619 : Serial PC cable (VIBROTIP)

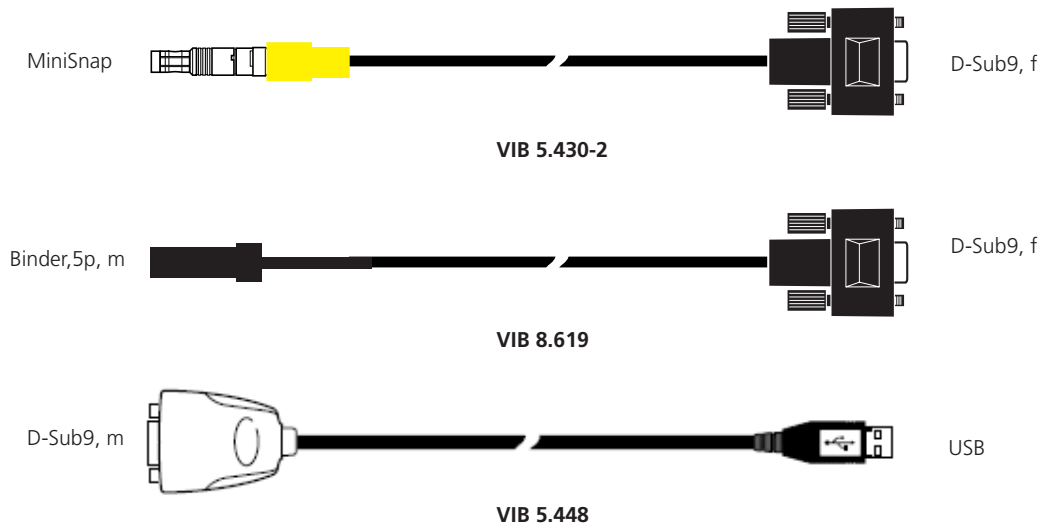

### Application

These cables are used for data transmission via the serial interface.

The adapter cable VIB 5.448 is additionally required if the PC or the laptop only has a USB port.

### Cable lengths

VIB 5.430-2 approx. 2 m

VIB 5.448 approx. 0.2 m

VIB 8.619 approx. 2 m

### Note

These cables may not be used with VIBXPRT EX or VIBROTIP EX respectively!

### Application examples

Data collector connected to PC (RS 232)

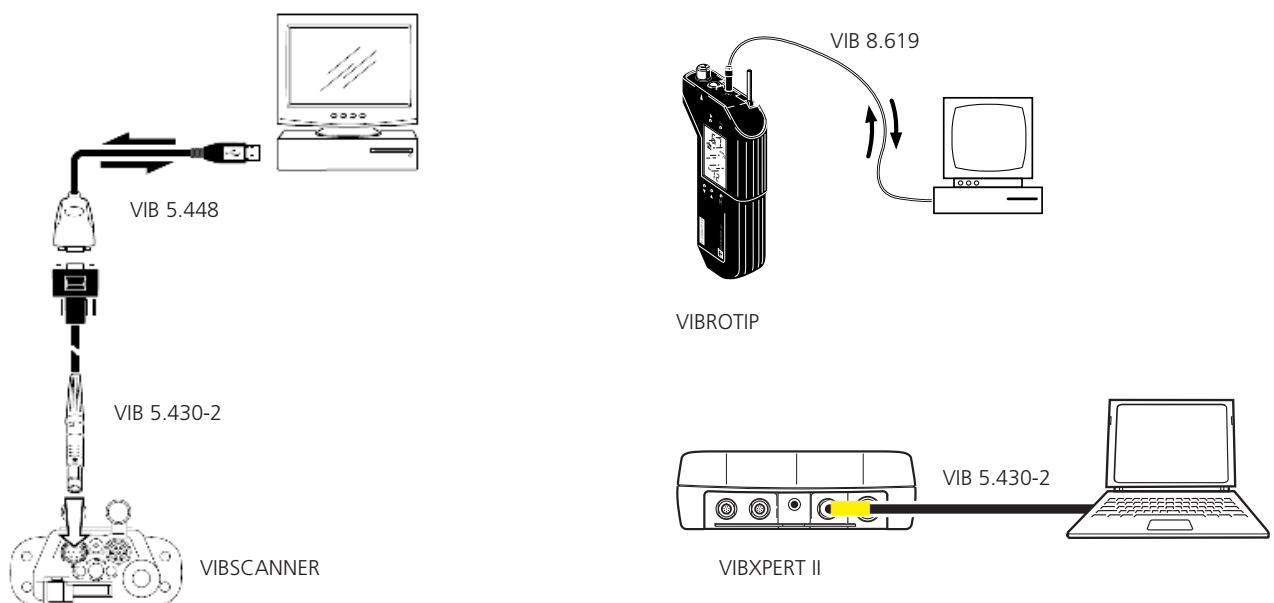

C

## VIB 8.619-USB : Serial to USB cable adapter for VIBROTIP EX

1

2

3

Binder 5p, m  USB

VIB 8.619-USB



4

### Application

This cable adapter is used with the VIBROTIP EX data collector for data transfer to a PC via an USB port. It protects the data collector from damage caused by surges and may only be connected temporarily - i.e. not permanent - to the USB port of a standard computer. The maximum voltage  $U_m$  on the USB port must not be greater than 60 volts, even under fault conditions.

5

6

Cable length approx. 1.5 m

### Note

This cable adapter may only be connected outside the hazardous area.

This cable adapter can also be used with VIBROTIP without intrinsic safety!

A

### Technical data

PARAMETER		VIB 8.619-USB
Electrical	Connectors	USB plug / Binder plug 5p
	Supply	5 VDC, from PC USB port
General	Length	approx. 1.5 m
	Operating temperature	-20°C ... + 50°C
	Storage temperature	-30°C ... + 80°C
	Relative humidity	< 95%
	Protection class	IP 50

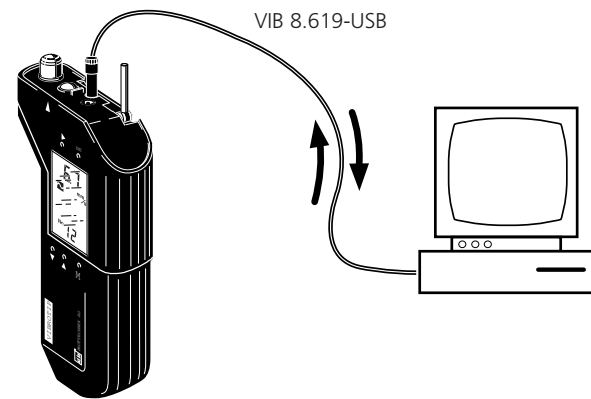

VIBROTIP EX

## Network cables for Online-CMS (VIBRONET Signalmaster / VIBROWEB)

VIB 5.955-X : Patch cable (VIBRONET Signalmaster / VIBROWEB)

VIB 5.957-2 : Crossover ethernet cable (VIBRONET Signalmaster / VIBROWEB), 2 m

VIB 5.957-5 : Crossover ethernet cable (VIBRONET Signalmaster / VIBROWEB), 5 m

X = 2,5,10,30 m

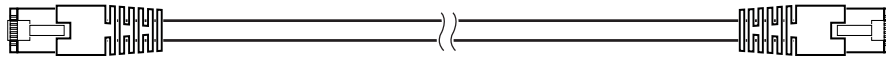

VIB 5.955-2

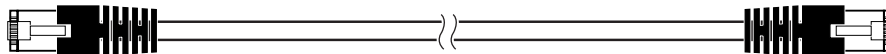

VIB 5.957-2

### Application

The Patch cable VIB 5.955-X is used to connect the CMS basic unit (VIBRONET Signalmaster / VIBROWEB) to a data network - either directly or via a switch.

The crossover ethernet cable VIB 5.957-X is used to connect the CMS basic unit directly to a PC.

### Abbreviation

CMS: Condition-Monitoring-System

### Technical data

PARAMETER		VIB 5.955-X	VIB 5.957-2 / -5	
Electrical	Charact. impedance	100 Ohm ±15%		
	Loop resistance	188 Ohm		
	Conductor resistance	< 94 Ohm/km		
Layout and Environment	Wire	0.52 mm Cu blk AWG24		
	Wire insulation	PE, color coding acc. to IEC 708		
	Formation	4 pairs, twisted		
	Shielding	Aluminium compound foil		
	Earth lead	0.5 mm Cu vzn		
	Sheath	FR-PVC, gray (flame resistant)	FR-LSOH, yellow (flame resistant, low-smoke, halogen-free)	
	External diameter	6.3 mm		
	Model	TP patch cable, shielded Category 5 - 100 Mbit/s, Allocation acc. to EIA/TIA 568, 4 x 2 x AWG 24/7 RJ 45 connector w/ sprayed on cable sleeve	S/FTP Crossover cable, double shielded Category 5 - 100 Mbit/s, Crossover allocation (100BASE-T4)*, 4 x 2 x AWG 26/7 RJ 45-'HIROSE' connector, yellow	
	Temperature range	-5°C ... +50°C (laying)		-30°C ... +70°C (operation)
Cable length	2, 5, 10 or 30 meters		2 meters or 5 meters	

\*Crossover pin allocation (100BASE-T4):  
1 - 3  
2 - 6  
3 - 1  
4 - 7  
5 - 8  
6 - 2  
7 - 4  
8 - 5

### Application example

VIBROWEB connected to network / PC

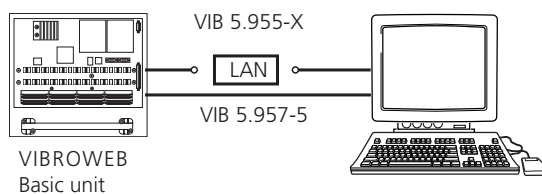

C

## VIB 5.956-X : System bus cable for VIBRONET Signalmaster with X connectors

1

2

3

4

5

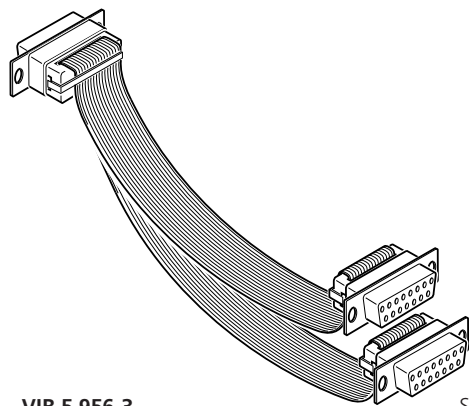

VIB 5.956-3

Sub-D 15p, f

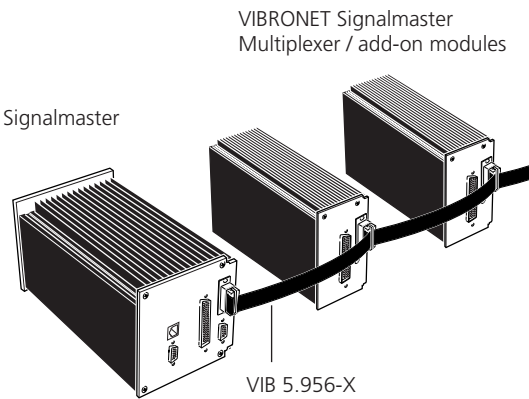
VIBRONET Signalmaster  
basic unitVIBRONET Signalmaster  
Multiplexer / add-on modules

VIB 5.956-X

X = 2...7

6

### Application

Connection of the 16-channel multiplexers and add-on modules to the VIBRONET Signalmaster for the transmission of analog and digital measurement and control signals.

A

### Description

The system bus cable is a 15-wire ribbon cable. At a distance of about 0.5 meter 15-pole Sub-D connectors are attached for connecting system components.

### Note

The expansion of an existing system bus requires a system bus cable with the relevant number of connectors.

### Pin allocation: System bus cable

PIN	Function
1	Hi3
2	Lo3
3	AG
4	MUX-CLK
5	12 V
6	PG
7	SDM1
8	SDM2
9	SDM3
10	AG
11	AG
12	Hi1
13	Lo1
14	Hi2
15	Lo2

12VDC/15mA 12V DC current supply  
 PG Reference zero for the 12V supply  
 AG Analog reference zero  
 MUX-CLK Impulse for channel switching  
 SDM A-wire for triggering  
 HiLo Analog signal line



# Appendix



- C
- 1
- 2
- 3
- 4
- 5
- 6
- A

## Ordering information for customized sensor cables

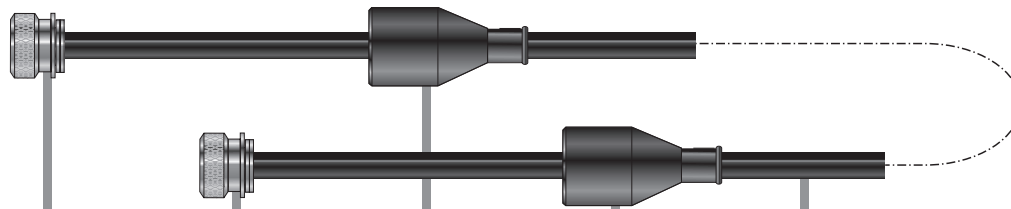

	VIB 3..	[Plug 1]	[Plug 2]	[Gland 1]	[Gland 2]	[Cable type]	L (S)		
<b>Order number</b>	0	no plug	0	no plug	0	no gland	0	coax, VIB 90009 flame retardant	This suffix indicates the cable length in meters.  Add the letter 'S' for cable with protective sheath. (See below examples)
	1	TNC, straight VIB 93022	1	TNC, straight VIB 93022	1	Gland for TNC VIB 10473	1	Gland for TNC VIB 10473	
	2	QLA	2	QLA	2	Anti-kink sleeve, silicon free VIB 81018	2	Anti-kink sleeve, silicon free VIB 81018	
	3	TNC, angled VIB 93077	3	TNC, angled VIB 93077	3	Silicone dust cap VIB 6.700	3	Silicone dust cap VIB 6.700	
	4	BNC, straight VIB 93060	4	BNC, straight VIB 93060	4	Vitone dust cap VIB 6.701	4	Vitone dust cap VIB 6.701	
	5	BNC, angled VIB 91009	5	BNC, angled VIB 91009	5	Silicone dust cap angled VIB 6.710	5	Silicone dust cap angled VIB 6.710	
	6	Chassis, BNC VIB 93090	6	Chassis, BNC VIB 93090	6	Vitone dust cap angled VIB 6.711	6	Vitone dust cap angled VIB 6.711	
	7	Chassis, TNC VIB 91000	7	Chassis, TNC VIB 91000	7	Shrink tubing	7	Shrink tubing	
	8	TNC socket, VIB 93047	8	TNC socket, VIB 93047	8	-	8	-	
	9	MIL plug, 2p VIB 94010	9	MIL plug, 2p VIB 94010	9	-	9	-	

### Ordering examples

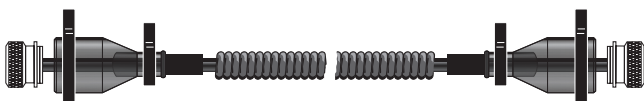

**VIB 311342-10S :**  
Coaxial cable with Rayolin cable sheath (oil- and heat-resistant up to 125°C) and with protective sheath 10 meters long;  
2x TNC plug, straight, with vitone and silicone glands



**VIB 303061-20S:**  
Coaxial cable (RG 58) with protective sheath, length 20m;  
1x TNC plug, angled, with vitone gland; one cable end open

### Acceptable combinations of cable types, plugs and glands

Designation, see above

CABLE TYPE	Plug	Gland
0, 1	all	all
2, 3*, 4	0, 1, 3, 6, 7	all
5*	0, 1, 3	3, 4, 5, 6, 7
6*, 7*	9	0
8*	0	0

\* Protective sheath VIB 6.730 is not allowed

## VIB 2.200 : Balancing and Vibration model (Rotor kit)

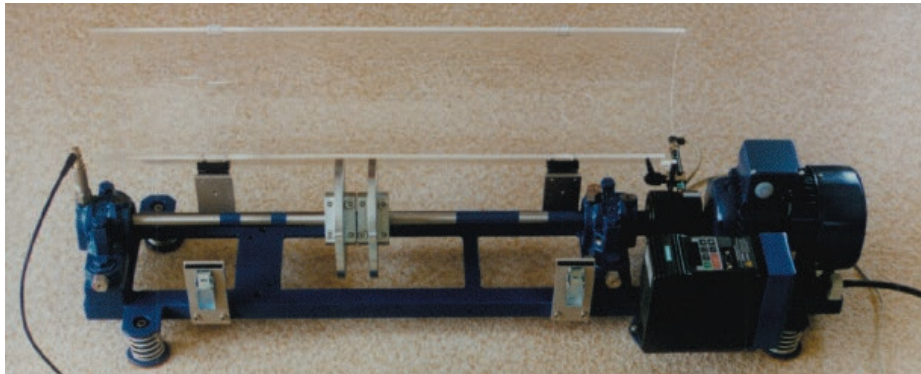

### Application

Simulation of actual machines for measurements in tests, demonstrations and training courses. The balancing and vibration model is suitable for the following applications:

- Balancing
- Diagnosis of machine faults
- Measurement of rolling bearing damage
- Investigations on Laval rotors

With a variable RPM and different degrees of stiffness of rotor and fundamnet, almost all the situations that occur on actual machines can be simulated. Individual components (bearings, rotor disk, rotor length) can be easily and rapidly replaced as a result of the simple construction of the model.

### Scope of supply

- Balancing machine with safety shutter, completely assembled
- Bonded adapter to M5 thread, flat, 6 pcs.
- Bonded adapter to M8, 2 pcs.
- VIBCODE long-stem stud, 2x
- Manual for frequency converter on CD
- Instructions for use
- Safety notes
- 1 set with 4 defective bearings (outer raceway, inner raceway, roll body)
- Tool set (fork wrench 3x, hook wrench, allen wrench for hex screws 2x, hammer, thickness gage, allen key)

### Balancing

- 1-plane and 2-plane balancing
- Replacing the rotor disk in less than 1 minute
- Overhung rotor
- Rotor in intermediate bearing
- Combination of overhung and intermediate mounted rotor
- Width and narrow impellers
- Rigid and soft foundation, adjustable
- Rigid and soft rotor, adjustable

### Machine faults and rolling bearing damage:

- Rotor resonance
- Rolling bearing race damage adjustable
- Rolling bearings can be exchanged
- Bearing clearance adjustable
- Static or dynamic unbalance
- Misalignment
- Loose foundation
- Foundation defect
- Foundation resonance, instability
- All errors at variable RPM
- Start up and coast down analysis

### Technical data

PARAMETER		VIB 2.200
Electrical	Power supply	SIEMENS frequency inverter 50/60 Hz, 230 VAC (115 VAC with adapter)
	RPM range	0 ... 3000 min. <sup>-1</sup> (60 Hz: 3600 min. <sup>-1</sup> )
	Drive	3~ DMA type 0.55 kW at 2775 min. <sup>-1</sup> /50 Hz 2.4 A at 230 VAC / 0.55 kW
Model	Machine	Rolling bearings in plummer block
	Motor, bearing mounting	M10/ wrench size 17
	Clearance to bearing center	460mm (short), 660 mm (long)
	Weight	25 kg (incl. motor, converter, cable)
	Rotor mass	5 - 8 kg adjustable
	Intrinsic frequencies	Foundation: rigid / soft (adjustable < 6 Hz) Rotor: 75 Hz, rigid, short shaft 48 Hz, soft, long shaft
	Bearing condition measurement	Bearing load as on actual machines with shock pulse measurements up to a RPM of 120min. <sup>-1</sup>
	Replacement time for rolling bearings	5 minutes

C

## Accelerometer performance characteristics (selection)

1

2

3

4

5

6

A

Accelerometer Order no.	Type	Sensitivity	Frequency range (±3dB)	Temperature range	Shock pulse bearing condition	IP class w/ cable	Intrinsic safety -> alternative
VIB 6.102 R	CLD	1.0 $\mu\text{A}/\text{ms}^{-2}$	1 Hz ... 20 kHz	-30°C...+80°C	yes	IP 65	no -> VIB 6.102 DEX
VIB 6.102 DEX	CLD	1.0 $\mu\text{A}/\text{ms}^{-2}$	1 Hz ... 20 kHz	-30°C...+80°C	yes	IP 65	yes
VIB 6.107	CLD	5.35 $\mu\text{A}/\text{ms}^{-2}$	0.3 Hz ...10 kHz	-30°C...+100°C	no	IP 65	no -> VIB 6.107 DEX
VIB 6.107 DEX	CLD	5.35 $\mu\text{A}/\text{ms}^{-2}$	0.3 Hz ...10 kHz	-30°C...+80°C	no	IP 65	yes
VIB 6.122 R	CLD	1.0 $\mu\text{A}/\text{ms}^{-2}$	1 Hz ... 20 kHz	-30°C...+100°C	yes	IP 65	no -> VIB 6.122 DEX
VIB 6.122 DEX	CLD	1.0 $\mu\text{A}/\text{ms}^{-2}$	1 Hz ... 20 kHz	-30°C...+80°C	yes	IP 65	yes
VIB 6.125 R	CLD	1.0 $\mu\text{A}/\text{ms}^{-2}$	1 Hz ... 20 kHz	-30°C...+135°C	yes	IP 65	no -> VIB 6.125 IDEX
VIB 6.125 RIP	CLD	1.0 $\mu\text{A}/\text{ms}^{-2}$	1 Hz ... 20 kHz	-30°C...+135°C	yes	IP 68 <sup>3</sup>	no -> VIB 6.125 IDEX
VIB 6.125 IDEX	CLD	1.0 $\mu\text{A}/\text{ms}^{-2}$	1 Hz ... 20 kHz	-30°C...+80°C	yes	IP 68 <sup>3</sup>	yes
VIB 6.127	CLD	5.35 $\mu\text{A}/\text{ms}^{-2}$	0.3 Hz ...10 kHz	-30°C...+100°C	no	IP 65	no -> VIB 6.127 DEX
VIB 6.127 DEX	CLD	5.35 $\mu\text{A}/\text{ms}^{-2}$	0.3 Hz ...10 kHz	-30°C...+80°C	no	IP 65	yes
VIB 6.129 IP	CLD	5.35 $\mu\text{A}/\text{ms}^{-2}$	0.3 Hz ...10 kHz	-30°C...+135°C	no	IP 68 <sup>3</sup>	no -> VIB 6.129 IDEX
VIB 6.129 IDEX	CLD	5.35 $\mu\text{A}/\text{ms}^{-2}$	0.3 Hz ...10 kHz	-30°C...+80°C	no	IP 68 <sup>3</sup>	yes
VIB 6.132 R	CLD	1.0 $\mu\text{A}/\text{ms}^{-2}$	1 Hz ... 20 kHz	-30°C...+100°C	yes	IP 65	no -> VIB 6.132 DEX
VIB 6.132 DEX	CLD	1.0 $\mu\text{A}/\text{ms}^{-2}$	1 Hz ... 20 kHz	-30°C...+80°C	yes	IP 65	yes
VIB 6.135 R	CLD	1.0 $\mu\text{A}/\text{ms}^{-2}$	1 Hz ... 20 kHz	-30°C...+135°C	yes	IP 65	no -> VIB 6.125 IDEX
VIB 6.137	CLD	5.35 $\mu\text{A}/\text{ms}^{-2}$	0.3 Hz ...10 kHz	-30°C...+100°C	no	IP 65	no -> VIB 6.137 DEX
VIB 6.137 DEX	CLD	5.35 $\mu\text{A}/\text{ms}^{-2}$	0.3 Hz ...10 kHz	-30°C...+80°C	no	IP 65	yes
VIB 6.142 R	CLD	1.0 $\mu\text{A}/\text{ms}^{-2}$	0.3 Hz ...20 kHz	-30°C...+100°C	yes	IP 65	no -> VIB 6.142 DEX
VIB 6.142 DEX	CLD	1.0 $\mu\text{A}/\text{ms}^{-2}$	0.3 Hz ...20 kHz	-30°C...+80°C	yes	IP 65	yes
VIB 6.147	CLD	5.35 $\mu\text{A}/\text{ms}^{-2}$	0.3 Hz ...12 kHz	-30°C...+100°C	no	IP 65	no -> VIB 6.147 DEX
VIB 6.147 DEX	CLD	5.35 $\mu\text{A}/\text{ms}^{-2}$	0.3 Hz ...12 kHz	-30°C...+80°C	no	IP 65	yes
VIB 6.152 DEX	CLD	0.1 $\mu\text{A}/\text{ms}^{-2}$	1 Hz ...20 kHz	-30°C...+80°C	yes	IP 65	yes
VIB 6.162 VD	CLD	1.0 $\mu\text{A}/\text{ms}^{-2}$	2 Hz...2 kHz (±10%)	-30°C...+80°C <sup>2</sup>	no	IP 65	yes
VIB 6.172	ICP	100 mV/g	0.1 Hz ...10 kHz	-40°C...+120°C	no	IP 67	no -> VIB 6.172 XICP
VIB 6.172 XICP	ICP	100 mV/g	0.1 Hz ...10 kHz	-40°C...+80°C	no	IP 67	yes
VIB 6.195	CLD	5.35 $\mu\text{A}/\text{ms}^{-2}$	0.1 Hz ...10 kHz	-30°C...+80°C	no	IP 67	no -> VIB 6.172 XICP
VIB 6.202-3 /-6	CLD	1.0 $\mu\text{A}/\text{ms}^{-2}$	2 Hz ...10 kHz	-30°C...+80°C	yes	IP 65	no -> VIB 6.202..XD
VIB 6.203-3 /-6	CLD	1.0 $\mu\text{A}/\text{ms}^{-2}$	2 Hz ...10 kHz	-30°C...+120°C	yes	IP 65	no -> VIB 6.203..XD
VIB 6.202..XD	CLD	1.0 $\mu\text{A}/\text{ms}^{-2}$	2 Hz ...10 kHz	-30°C...+80°C	yes	IP 65	yes
VIB 6.203..XD	CLD	1.0 $\mu\text{A}/\text{ms}^{-2}$	2 Hz ...10 kHz	-30°C...+80°C	yes	IP 65	yes
VIB 6.215	V / ICP	20 mV/ms <sup>-2</sup> (Z)	1 Hz ... 10 kHz (Z)	-40°C...+85°C	no	IP 65	no -> none
VIB 6.216	V / ICP	20 mV/ms <sup>-2</sup> (Z)	0.1 Hz ... 10 kHz (Z)	-40°C...+85°C	no	IP 65	no -> none
VIB 6.655	ICP	100 mV/g	0.6 Hz ...2 kHz <sup>1</sup>	-54°C...+121°C	no	--	no -> none
VIB 8.606 VS	CLD	1.0 $\mu\text{A}/\text{ms}^{-2}$	10 Hz...10 kHz (±10%)	-10°C...+80°C	yes	IP 65	no -> VIB 8.606 XVS
VIB 8.606 XVS	CLD	1.0 $\mu\text{A}/\text{ms}^{-2}$	10 Hz...10 kHz (±10%)	-10°C...+80°C	yes	IP 65	yes
VIB 8.660 VS	CLD	1.0 $\mu\text{A}/\text{ms}^{-2}$	1.5 Hz ...20 kHz	-10°C...+70°C	yes	IP 65	no -> VIB 8.660 XVS
VIB 8.660 XVS	CLD	1.0 $\mu\text{A}/\text{ms}^{-2}$	1.5 Hz ...20 kHz	-10°C...+70°C	yes	IP 65	yes
VIB 8.666 VS	CLD	1.0 $\mu\text{A}/\text{ms}^{-2}$	1 Hz...10 kHz (±5%)	-30°C...+100°C	yes	IP 65	no -> none

### Abbreviations

ICP: Integrated Circuit Piezoelectric (Sensor w/ voltage output)

CLD: Current Line Drive (Sensor w/ current output)

<sup>1</sup> w/ magnetic holder VIB 3.420

<sup>2</sup> outside hazardous area: -30°C...+100°C

<sup>3</sup> w/ VIB 6.760 or VIB 6.761

C

1

2

3

4

5

6

A

## Portable instruments connection overview

### Legend

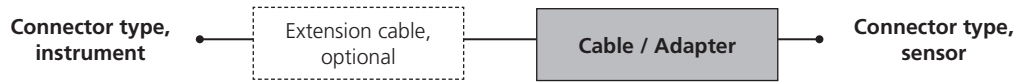

### Note

For cable lengths greater than 2.9 meters, the EMC immunity of the signal path can be adversely affected.

## Current LineDrive Accelerometers (CLD)

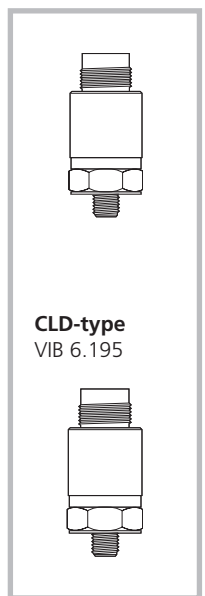
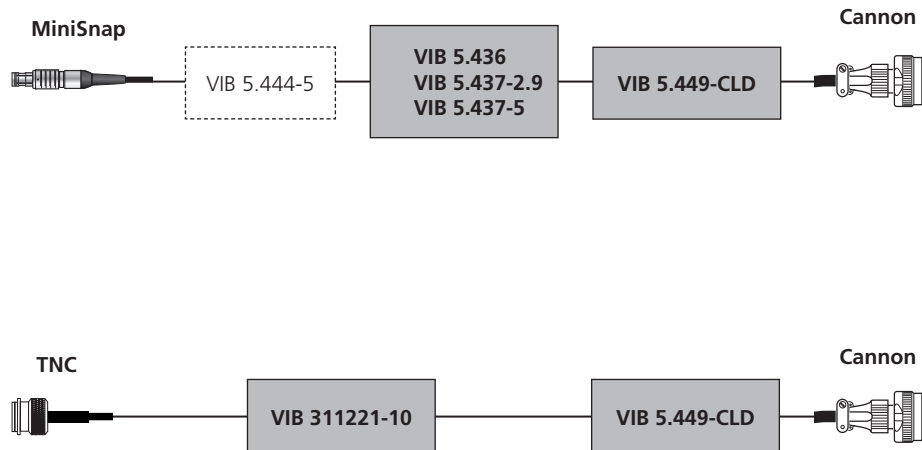
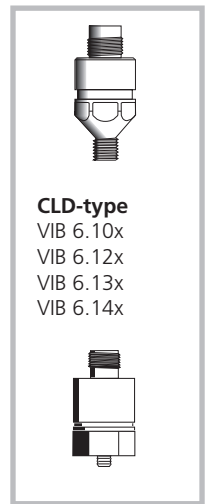
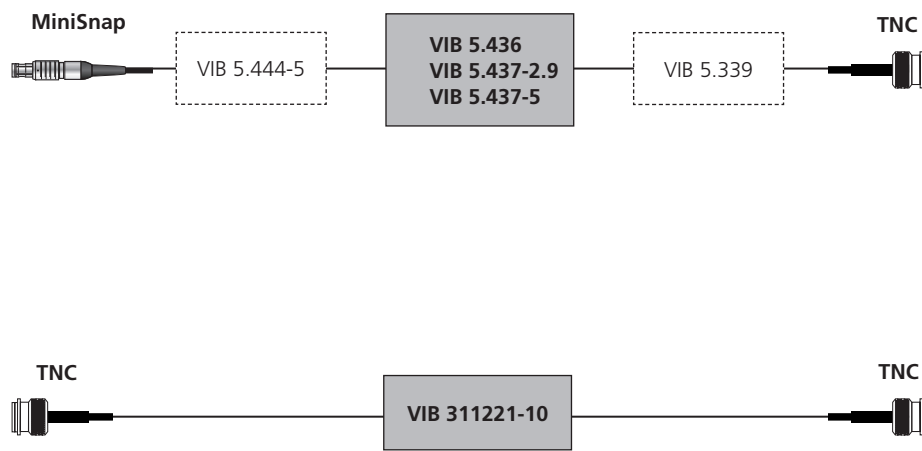

- C
- 1
- 2
- 3
- 4
- 5
- 6

## ICP-type Accelerometers

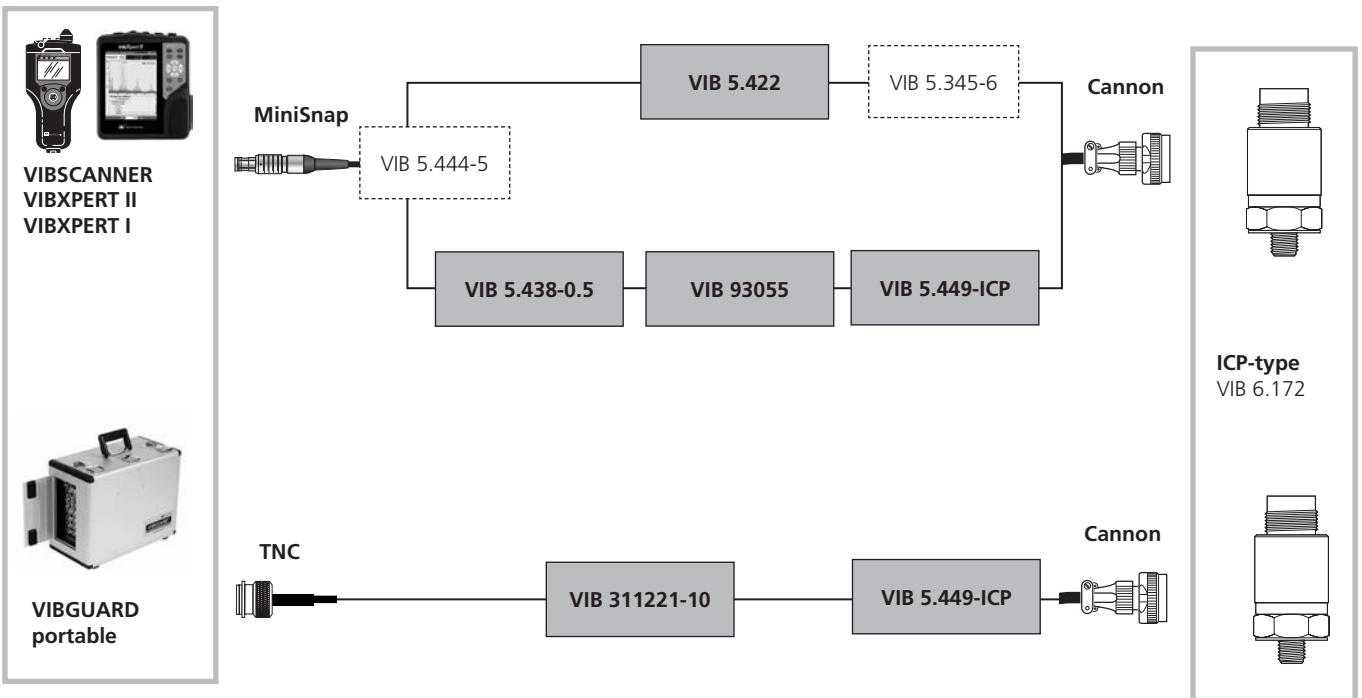

## A

## Microphone, ICP-type

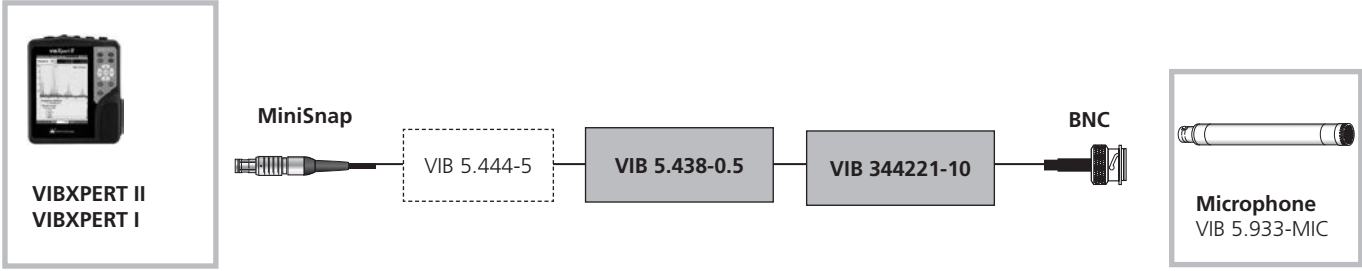

## VIBREX (mV)

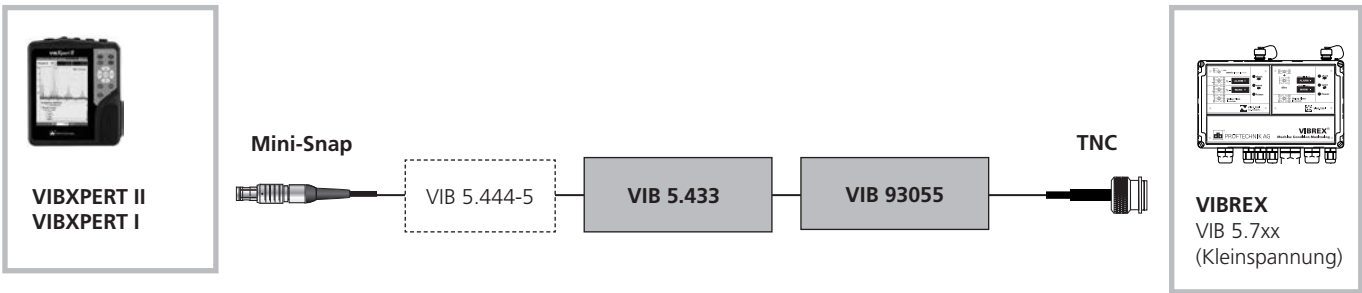

## VIBROTECTOR

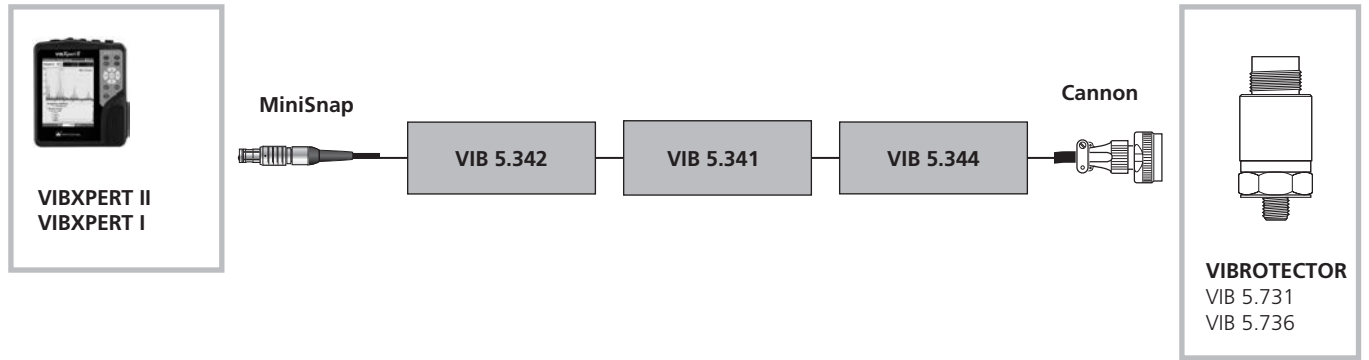

## Data collection via multiplexer

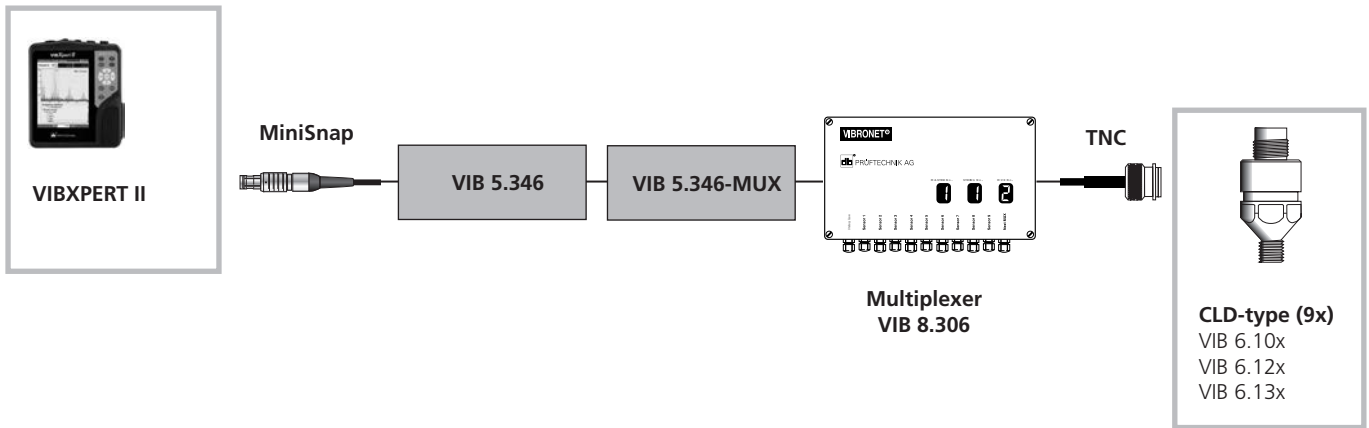

## Machine protection system

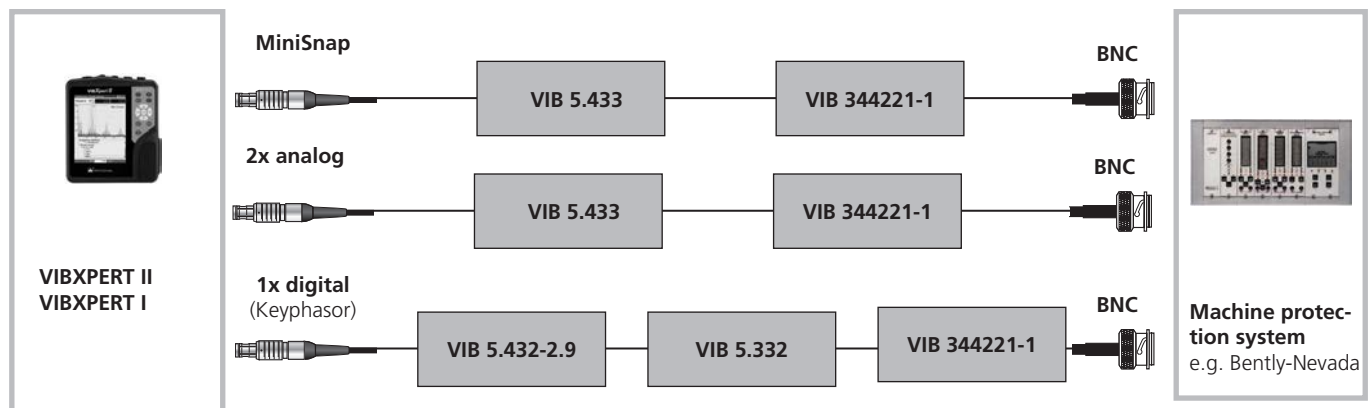

- C
- 1
- 2
- 3
- 4
- 5
- 6
- A

## C

## Information about installing sensors and cables in hazardous areas

## 1

### Conditions for safe operation of the signal evaluation units and the transducers

## 2

0. Responsibility for the installation of intrinsic safe systems:

## 3

- Each intrinsic safe company has an authorized EX protection representative who is solely aware which conditions, norms, etc. must be observed in his company. Only the specialist personnel he authorizes are allowed to work on the system.

## 4

- The following installation recommendations must be authorized by the EX protection representative.

## 5

1. Limiting device for transducers with Current LineDrive output: VIB 3.550

## 6

- The limiting device must be installed in a connection box or housing (min. IP 20).
- The limiting device must be at least 50 mm away from non-intrinsically safe circuits.
- The potential equalization connector must be applied first and should not be connected through.
- The signal evaluation unit must be earthed with the hazardous areas equipotential bonding system (PA) at the position of the limiting device.
- The only grounded point of the intrinsically safe circuits within the hazardous area is the limiting device.
- The limiting device should have potential equalization with the machines to be monitored.

## A

2. Transducers

- Electrically non-insulated transducers may only be used in the area of the machine with electrically non-insulated and PA-contacted fittings.
- The insulated sensors with Current Line- Drive output and the intermediate connectors must be reliably protected against physical contact. To do this, they must be fitted with the IP68 option or with caps beyond the insulated position and fixed with plastic clamps.



3. Wiring to the hazardous areas equipotential bonding system (PA)

- For reasons of noise suppression, a line resistance of <math><120\text{ m}\Omega</math> is recommended (e.g. Cu cable, AWG 16 (1.5 mm<sup>2</sup>) / 10 meters long).
- The following safety regulations must be implemented: personnel, goods, with respect to lightning, explosion, electricity and, if necessary, any other regulations of the respective customers, trade union, insurers, country, confederation, etc. must be taken into account.
- The respective installation regulations regarding the safety of the type of connection must also be followed here. Consequently, this must be performed by an authorized specialist there who is insured to do so.

4. Cables

Coaxial and triaxial cables are used for LineDrive sensors with TNC connectors (VIB 6.1..EX) or with sealed cable connection (VIB 6.2...XD, coaxial only) respectively. Twisted-pair cables are used for sensors with 2-pin ML connectors\*.

The outer shield of the triax cable must ...

- ... be connected to the hazardous areas equipotential bonding system at the limiting device (PA).
- ... not be connected to the sensor, but reliably insulated instead (under shrinkage tube or insulating cap, 5mm gap to the plug.)
- ... not be connected to the metal housing at the sensor intermediate connector (VIB 6.770/13), but reliably insulated instead or the metal housing should be insulated by shrinkage tube.
- ... be insulated by shrinkage tube or insulating cap when using cable interconnections.

5. The national safety regulations must be followed.

6. The conformity certifications must be observed.

7. The EX protection instructions in the various catalog pages must be adhered to.

\* VIBROTECTOR EX, VIB 5.73x EX  
ICP-type accelerometer EX, VIB 6.172XICP



**Connection examples:**

Limiting device (VIB 3.550) for Linedrive accelerometers

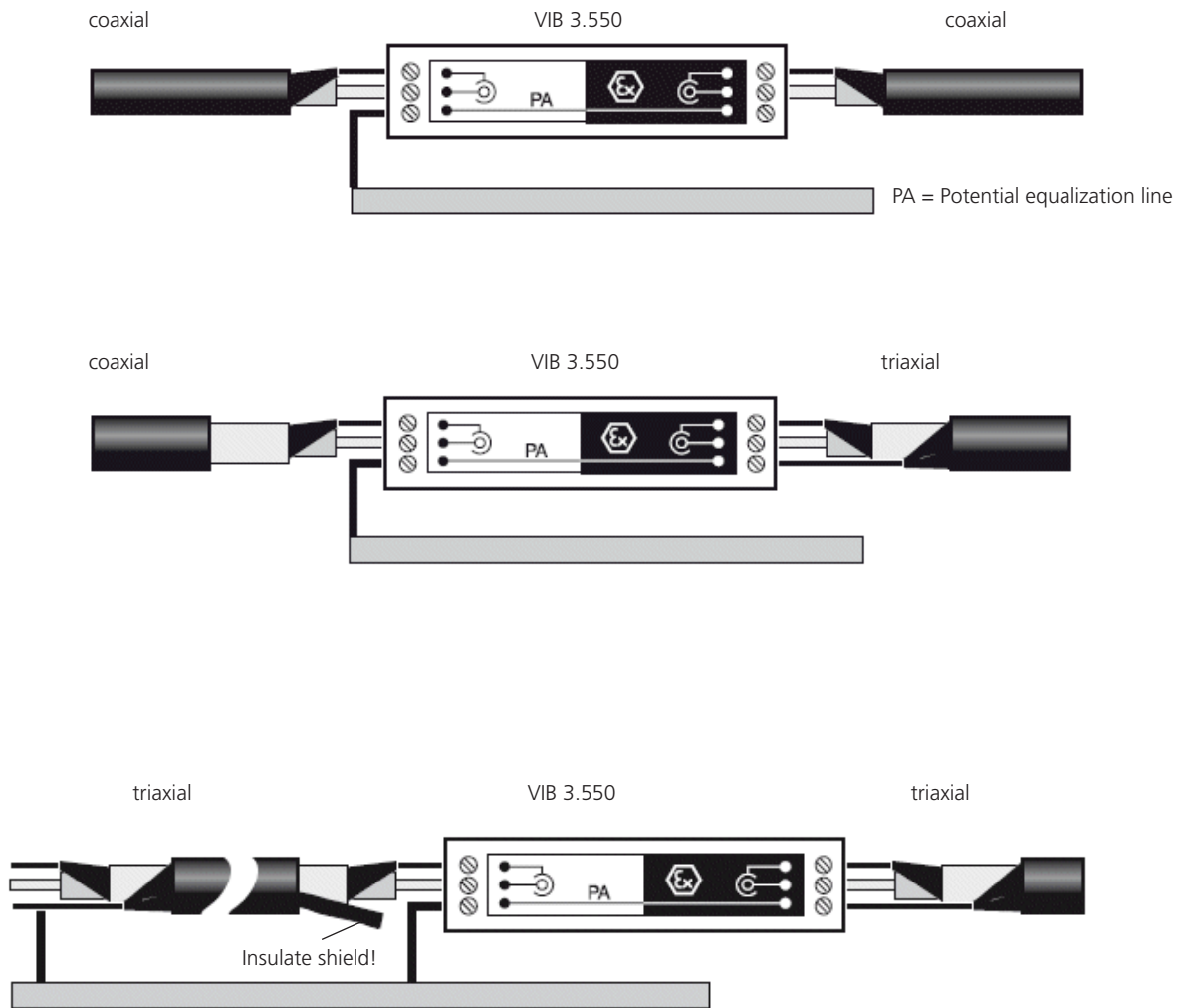

Evaluation unit side:  
Connect outer shield to PA!

**C Installation examples in the hazardous area:**

1

2

3

4

5

6

**A**

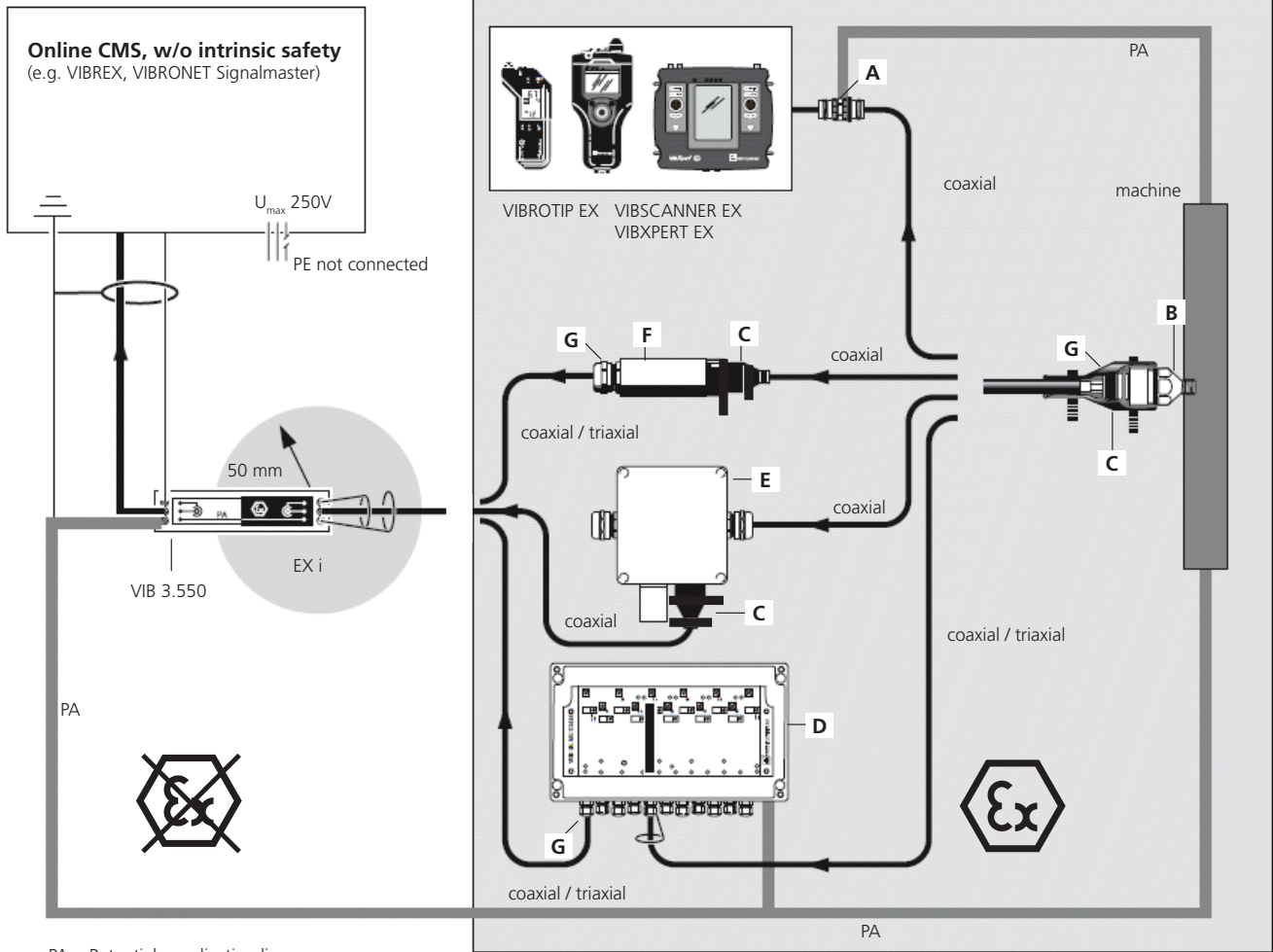

PA = Potential equalization line

A	B	C	D	E	F	G
VIB 93036 S	VIB 6.1x2 DEX x= 0, 2, 3, 4	VIB 6.700 + VIB 6.720 + VIB 6.721 + VIB 6.722	VIB 8.306 EX Field multiplexer, mounted insulated	VIB 6.775/9	VIB 6.770/9 mounted insulated	Outer shield is not connected
VIB 93036 F VIB 91000	VIB 6.1x7 DEX x= 0, 2, 3, 4	VIB 6.760 VIB 6.761	VIB 8.314 EX Vibration module	VIB 6.775/13	VIB 6.770/13 mounted insulated	

coaxial

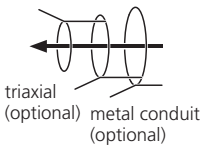

## The patented Tandem-Piezo accelerometer

### PRÜFTECHNIK accelerometers provide measurable success

PRÜFTECHNIKs patented Tandem-Piezo accelerometers set new standards in terms of reliability, versatility, mounting ease and economy.

The unique design practically eliminates temperature shock and base strain effects; it also handles condition evaluation of turbo machinery and gearboxes, anti-friction bearings and pump cavitation - all with the same transducer, thanks to a wide linear range and a defined shock pulse resonance characteristic at 36 kHz. The built-in current line drive amplifier ensures immunity to ground looping and extremely low signal loss, even over long transmission distances, as well as compatibility with the entire PRÜFTECHNIK line of mobile data collectors, FFT analyzers and online or remote condition monitoring equipment.

And the Tandem-Piezo transducer family not only costs far less than shear designs, but cuts installation expense as well: economical standard TNC fittings mount quickly and are available with flexible caps (silicone-free, if desired) for extra protection. Laser-welded and laser-marked, the

hermetically sealed housings withstand even the harshest industrial surroundings. Angled plugs require only 45 mm mounting clearance height; besides standard stud mounting, a revolutionary bonded arrangement is ideal for mounting on thin-profile bearing housings. A self-threading pin holds the accelerometer in place using only a small pilot hole while the bonding compound sets to a final hardness comparable to that of steel.

### Tandem-Piezo® accelerometer at a glance

- Low base strain sensitivity
- Low sensitivity to temperature transients
- Built-in 'Linedrive' amplifier offers unsurpassed immunity against cable noise and ground loops
- Low transverse sensitivity
- High shock resistance
- Integrated resonance suppression filters avoids amplifier overloading
- Factory burn-in for high long-term stability
- Intrinsically safe version also available

Tandem-Piezo® accelerometer design

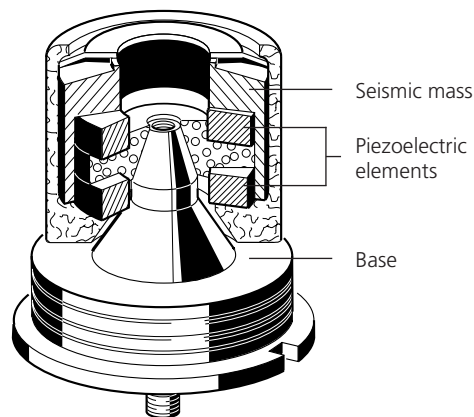

## C

## Advantages of current linedrive accelerometers

1 The long cables used in permanent monitoring systems must stand up to considerable electrical and mechanical interference. With traditional sensors the signals barely get through the network, being drowned out by the noise and interference.

2 The solution: use either expensive high-quality cable carefully laid away from interference sources or a 'line drive' system, which consists of a tiny electronic amplifier built into each sensor which boosts the vibration signal. The latter offers several advantages:

- 3
- 4 • Low sensitivity to mechanical and electrical interference (cable noise, electromagnetic sources, ground looping)
  - 5 • Very long low-cost cables possible with very little signal loss
  - 6 • Cable positioning during installation is not as critical
  - Power supply current carried along the very same coaxial cable carrying the vibration signal (power comes from a source built into the receiver instrument).

A There are two types of line drive systems on the market, providing either voltage output or current output. PRÜFTECHNIK systems use the latter, since it is a superior system with more sophisticated electronics and the following significant advantages:

- Much lower high frequency loss in very long cables even over 1000 meters.
- Much lower susceptibility to induced noise and ground-loop noise, also obviating in most cases the need for insulated sensors.

### High frequency loss in long cables

The PRÜFTECHNIK current line driver system has much lower high frequency loss in long cables than voltage output systems.

This is because the instrument has a significantly lower input impedance, and since the maximum frequency is inversely proportional to input impedance, the maximum frequency is greatly extended.

### Ground looping and noise

The PRÜFTECHNIK current line driver system has much lower susceptibility to induced noise and ground-loop noise than voltage output systems.

This is because the very low instrument input impedance minimizes influence from electromagnetic fields. The instrument virtually 'shorts' the cable conductors.

This has the added advantage that, with the exception of frequency rectifier-governed motors and high-voltage motors, costly insulated sensors can be avoided, eliminating the problem of insulator capacitance.

Frequency range and signal loss depend on cable length

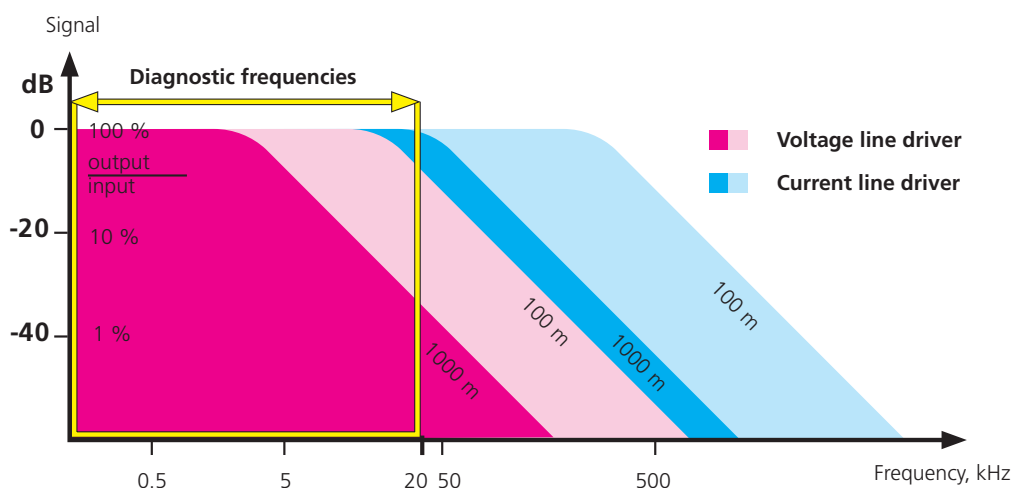

## PRÜFTECHNIK worldwide

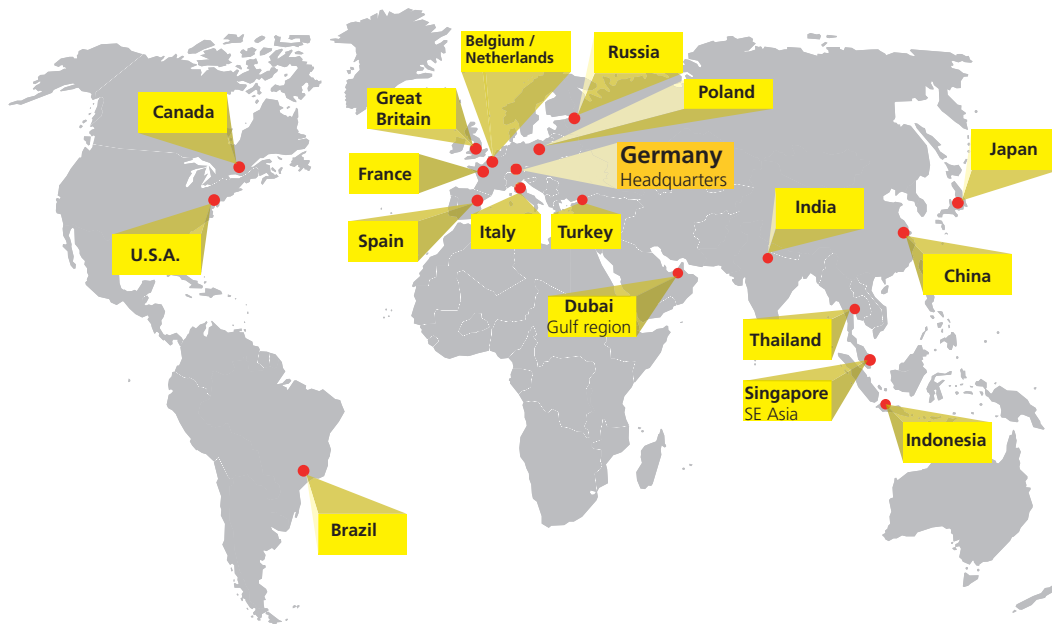
**Belgium / Netherlands**

PRUFTECHNIK N.V.  
Bothastraat 9  
B-2140 Antwerpen  
www.pruftechnik.be  
Tel.: +32 (0) 3 272 56 36  
Fax: +32 (0) 3 272 40 74  
info@pruftechnik.be  
Brain Park II  
Lichtenauerlaan 102-120  
NL-3062 ME Rotterdam  
Tel.: +31 (0)10 204 59 37  
Fax: +31 (0)10 204 55 55

**Brazil**

PRUFTECHNIK Ltda.  
R. Gaspar Soares, 178 - Santana  
02041-020 São Paulo - SP  
www.pruftechnik.com.br  
Tels.: +55 11 3571-7710  
Celular: +55 11 9944-1409  
info@pruftechnikbrasil.com.br

**Canada**

PRUFTECHNIK Maintenance  
Technology Service, Inc.  
4406, rue Louis-B.-Mayer  
Laval, QC H7P 0G1  
www.pruftechnik.ca  
Tel: +1 (514) 738-6565  
Fax: +1 (514) 227-5455  
info@pruftechnik.ca

**China**

PRUFTECHNIK  
Trading (Shanghai) Co., Ltd  
21F, Room 03,04 Tower A,  
Hongkou Plaza  
No. 388 West Jiangwan Road,  
Hongkou District  
Shanghai 200083, P.R. China  
Tel.: +86 21 65075118  
Fax: +86 21 65075115

**France**

PRUFTECHNIK S.A.R.L.  
Parc d'Activités Lavoisier  
Rue Laplace  
F - 59494 Petite Forêt  
www.pruftechnik.fr  
Tel.: +33 (0) 3 27 25 52 33  
Fax: +33 (0) 3 27 25 55 69  
info@pruftechnik.fr

**Germany**

PRUFTECHNIK AG  
Oskar-Messterstr. 19-21  
85737 Ismaning  
www.pruftechnik.com  
Tel.: +49 (89) 996160  
Fax: +49 (89) 99616300  
info@pruftechnik.com

**Great Britain / Ireland**

PRUFTECHNIK LTD.  
Plant Lane Business Park,  
Burntwood Staffordshire  
WS7 3GN  
www.pruftechnik.co.uk  
Tel.: +44 (0) 1543 448350  
Fax: +44 (0) 1543 275472  
info@pruftechnik.co.uk

**Gulf region**

PRUFTECHNIK Middle East FZE  
Dubai Airport Free Zone  
P.O. Box 293872  
United Arab Emirates  
Phone: +971 4 214 6386  
Fax: +971 4 214 6390  
info@pruftechnik.com

**Italy**

PRUFTECHNIK S.r.l.  
Via De Nicola, 12/E  
I-20090 Cesano Boscone (MI)  
www.pruftechnik.it  
Tel.: +39 02 4516141  
Fax: +39 02 45161430  
info@pruftechnik.it

**India**

PRUFTECHNIK AIMIL Technical  
Services Private Limited  
A-8 Mohan cooperative industrial  
estate, Mathura road,  
Phone: 91-265-3058800/03  
Dehli - 110044, India

**Indonesia**

PRUFTECHNIK S.E.A PTE LTD  
Indonesia Representative Office  
Jl. H. R. Rasuna Said, Blok X-5, Kav  
1-2, Menara Karya, Lantai 28  
Jakarta 12950 Indonesia

**Japan**

PRUFTECHNIK K.K.  
Hoshikawa Sanchoume Building  
3-3-29 Hoshikawa, Hodogaya-ku,  
Yokohama-city  
Kanagawa 240-0006  
www.pruftechnik.jp  
Tel: +81 45 444 8812  
Fax: +81 45 444 8813

**Poland**

PRUFTECHNIK WIBREM sp. z o.o.  
ul. Sulowska 43  
51-180 Wroclaw, Polska  
www.pruftechnik.com.pl  
Tel.: +48 71 326 57 00  
Fax: +48 71 326 57 10  
info@pruftechnik.com.pl

**Russia**

OOO PRUFTECHNIK  
Prospekt Stachek 48  
Office 505  
198097 Saint Petersburg  
www.pruftechnik.ru  
Tel.: +7 812 313 00 85  
info@pruftechnik.ru

**South East Asia**

PRUFTECHNIK S.E.A. Pte. Ltd.  
61 Alexandra Terrace  
#05-03 Harbour Link Complex  
Singapore 119936  
www.pruftechnik.com.sg  
Tel.: +65 6382 0662  
Fax: +65 6382 0776  
office@pruftechnik.com.sg

**Spain**

PRUFTECHNIK, S.L.  
Calle Frederic Mompou, 4b, 4º, 4  
08960 St. Just Desvern (Barcelona)  
www.pruftechnik.es  
Tel.: +34 934 802 700  
Fax: +34 934 802 705  
contacto@pruftechnik.es

**Thailand**

PRUFTECHNIK S.E.A PTE. Ltd.  
Thailand Representative Office  
Vanissa Building, Room 10B  
29 Soi Chidlom, Ploenchit Road  
Lumpini, Patumwan  
Bangkok 10330, Thailand  
Tel: +66 2 655-2989  
Fax: +66 2 655-0900  
eMail: office@pruftechnik.com.sg

**Turkey**

PRUFTECHNIK Proaktif Bakım  
Teknolojileri ve Hizmetleri San. ve  
Tic. Ltd. Şti.  
Barbaros mh. Çigdem Sokak No:1  
Ağaoğlu My Office Kat 4/18  
34746 Ataşehir İstanbul / Türkiye  
Tel: +90 216 250 22 44  
Fax: +90 216 250 55 56

**U.S.A.**

PRUFTECHNIK Service, Inc.  
22 West Church Street  
Blackwood, NJ 08012  
www.pruftechnik.com  
Tel.: +1 (856) 401-3095  
Fax: +1 (856) 401-1484  
info@pruftechnik-service.com

## C PRÜFTECHNIK Service & Diagnostic Center

1 PRÜFTECHNIK develops and produces not only top-class condition monitoring systems, but also offers its customers professional services and practically oriented seminars in the field of condition based maintenance.

2

3

4

5

6

A

The PRÜFTECHNIK Service & Diagnostic Center handles the coordination and execution of tasks.



### Mobile measurement and diagnostic service

- Measurements for acceptance tests
- Balancing and alignment services on special machines
- Mobile vibration diagnosis measurements
- Special mobile measurement such as noise and strain analyses
- Inspection services including videoscopy and thermographic examinations

### In-house engineering and training

- Implementation of Condition Monitoring programs, including reference measurements
- Consultation and assistance in introducing a Condition Monitoring program
- Customized in-house training courses for machine operators and service providers

### Temporary installations & tediagnosis service

- Temporary online monitoring of machines and systems
- Remote monitoring of machines and systems
- Load collective determination and automatic overload monitoring
- Regular vibration diagnosis service with results in the form of reports or on the Internet (OMNITREND Web)

### Consulting and engineering

- Development of Condition Monitoring strategies for machine operators and manufacturers
- Machine failure and damage analyses
- Machine condition assessment by independent surveyors
- Working load determination and simulation to optimize existing drive systems
- FMEA of mechanical drives (root cause analysis)

## Index by order number

Order no.	Page	Order no.	Page	Order no.	Page	Order no.	Page
0 2088 0009	127	VIB 5.731 EX	44	VIB 6.730	115	VIB 8.660 VD	64
0 2088 0010	127	VIB 5.736	32	VIB 6.760	144	VIB 8.660 VS	64
VIB 2.200	187	VIB 5.736 EX	44	VIB 6.761	144	VIB 8.660 XVD	66
VIB 3.306	104	VIB 5.740-X	120	VIB 6.770/9	129	VIB 8.660 XVS	66
VIB 3.411	93	VIB 5.741-X	120	VIB 6.770/9-S	129	VIB 8.666 VD	80
VIB 3.412	93	VIB 5.745-L	121	VIB 6.770/13	129	VIB 8.666 VS	80
VIB 3.413	93	VIB 5.746-L	121	VIB 6.770/13-S	129	VIB 8.679 SET	99
VIB 3.414	93	VIB 5.771	124	VIB 6.775/9	131	VIB 8.680 A25	99
VIB 3.415	93	VIB 5.955-X	183	VIB 6.775/13	131	VIB 8.680 SET	99
VIB 3.416	93	VIB 5.956-X	184	VIB 6.776	129	VIB 8.685 A25	102
VIB 3.417-M5	94	VIB 5.957-2	183	VIB 6.780	170	VIB 8.685 SET	102
VIB 3.417-M6	94	VIB 5.957-5	183	VIB 6.785	171	VIB 8.689 A25	99
VIB 3.418	96	VIB 5.991-DIS	48	VIB 7.115-6	125	VIB 8.689 SET	99
VIB 3.420	97	VIB 5.992-NX	49	VIB 7.115-12	125	VIB 8.690 A25	99
VIB 3.422	97	VIB 5.992-STD	50	VIB 7.205-2,9	28	VIB 8.690 SET	99
VIB 3.423	97	VIB 5.993-MIC	56	VIB 7.560	135	VIB 8.691	64
VIB 3.430	96	VIB 6.102 DEX	36	VIB 7.580	136	VIB 8.692	103
VIB 3.431	96	VIB 6.102 R	20	VIB 7.581	136	VIB 8.693	107
VIB 3.432	96	VIB 6.107	22	VIB 7.582	136	VIB 8.694	107
VIB 3.433	96	VIB 6.107 DEX	40	VIB 7.583	136	VIB 8.696	107
VIB 3.435	95	VIB 6.122 DEX	36	VIB 7.590	137	VIB 8.718	115
VIB 3.436	95	VIB 6.122 R	20	VIB 7.591	137	VIB 8.745	143
VIB 3.437	94	VIB 6.125 IDEX	24	VIB 7.592	137	VIB 8.746-VD	172
VIB 3.438	94	VIB 6.125 R	20	VIB 7.593	137	VIB 8.746-VS	172
VIB 3.439	94	VIB 6.125 RIP	24	VIB 7.595	137	VIB 8.749	167
VIB 3.440	95	VIB 6.127	22	VIB 8.140-USB	60	VIB 8.772	95
VIB 3.441	95	VIB 6.127 DEX	40	VIB 8.170	60	VIB 10473	170
VIB 3.450	106	VIB 6.129 IDEX	24	VIB 8.171	60	VIB 32000	105
VIB 3.474	95	VIB 6.129 IP	24	VIB 8.172	60	VIB 32010	105
VIB 3.475	95	VIB 6.132 DEX	36	VIB 8.173	60	VIB 32200	105
VIB 3.480	94	VIB 6.132 R	20	VIB 8.306	132	VIB 32210	105
VIB 3.550	127	VIB 6.135 R	20	VIB 8.306 EX	133	VIB 32310	105
VIB 3.570-L	122	VIB 6.137	22	VIB 8.306 S	132	VIB 32410	105
VIB 3.575-10	123	VIB 6.137 DEX	40	VIB 8.306 V	132	VIB 33000 A25	105
VIB 3.575-20	123	VIB 6.142 DEX	70	VIB 8.310	134	VIB 81025	105
VIB 4.701-2	150	VIB 6.142 R	68	VIB 8.310 EX	134	VIB 81026	114
VIB 4.701-5	150	VIB 6.147	69	VIB 8.312	134	VIB 81052	114
VIB 4.702-2	150	VIB 6.147 DEX	72	VIB 8.313	134	VIB 81053	114
VIB 4.702-5	150	VIB 6.152 DEX	38	VIB 8.313 EX	134	VIB 81054	114
VIB 4.704-2	150	VIB 6.162 VD	74	VIB 8.314 EX	134	VIB 81060	137
VIB 4.704-5	150	VIB 6.162 VT	74	VIB 8.563 A25	103	VIB 90006	112
VIB 4.705	169	VIB 6.172	34	VIB 8.566	103	VIB 90007	112
VIB 4.750-5	157	VIB 6.172 XICP	46	VIB 8.568/B	103	VIB 90008	112
VIB 5.330 MEM	177	VIB 6.195	34	VIB 8.568/GN	103	VIB 90009	112
VIB 5.330 MUSB	173,177	VIB 6.202-3	26	VIB 8.568/GR	103	VIB 90030	119
VIB 5.330 SUSB	173,177	VIB 6.202-6	26	VIB 8.568/W	103	VIB 90061	117
VIB 5.330 UNV	178	VIB 6.202-6XD	42	VIB 8.568/Y	103	VIB 90065	117
VIB 5.330-USB	177	VIB 6.202-10XD	42	VIB 8.571	101	VIB 90070	118
VIB 5.331	180	VIB 6.203-3	26	VIB 8.572	101	VIB 90080	113
VIB 5.332	159	VIB 6.203-3XD	42	VIB 8.573	101	VIB 90093	112
VIB 5.332-X	160	VIB 6.203-6	26	VIB 8.576	100	VIB 90180	113
VIB 5.333	161	VIB 6.203-6XD	42	VIB 8.577	100	VIB 91000	140
VIB 5.336	162	VIB 6.215	30	VIB 8.578	100	VIB 91001	138
VIB 5.338	178	VIB 6.216	30	VIB 8.580	100	VIB 91002	138
VIB 5.339	149	VIB 6.411 SET	58	VIB 8.581	100	VIB 91009	138
VIB 5.341	163	VIB 6.420-L	126	VIB 8.582	100	VIB 93022	138
VIB 5.342	163	VIB 6.421	126	VIB 8.586	98	VIB 93031	138
VIB 5.343	163	VIB 6.425	126	VIB 8.587	98	VIB 93033	138
VIB 5.344	163	VIB 6.426-L	126	VIB 8.588	98	VIB 93035	140
VIB 5.345-6	152	VIB 6.610	51	VIB 8.589	98	VIB 93036 F	140
VIB 5.346	173	VIB 6.620	52	VIB 8.590	98	VIB 93036 S	140
VIB 5.346-MUX	173	VIB 6.620 SET	52	VIB 8.591	98	VIB 93047	138
VIB 5.422	152	VIB 6.621	52,53	VIB 8.592	98	VIB 93055	138
VIB 5.430-2	181	VIB 6.622	53	VIB 8.594	101	VIB 93056	140
VIB 5.431	158	VIB 6.622 SET	53	VIB 8.595	101	VIB 93060	138
VIB 5.432-2,9	157	VIB 6.631	84	VIB 8.596	101	VIB 93061	140
VIB 5.433	153	VIB 6.631 EX	86	VIB 8.605	82	VIB 93062	138
VIB 5.433-X	155	VIB 6.632	104	VIB 8.606 VD	76	VIB 93067	138
VIB 5.434	153	VIB 6.640	88	VIB 8.606 VS	76	VIB 93077	138
VIB 5.436	147	VIB 6.641	54	VIB 8.606 XVD	78	VIB 93090	140
VIB 5.437-2,9	147	VIB 6.645 SET	55	VIB 8.606 XVS	78	VIB 94010	139
VIB 5.437-5	147	VIB 6.655	81	VIB 8.607-1,5	82	VIB 94011	139
VIB 5.438-0,5	152	VIB 6.672	89	VIB 8.608	82	VIB 309007-6	125
VIB 5.439	165	VIB 6.673	90	VIB 8.609	76,78	VIB 309007-10	125
VIB 5.443	157	VIB 6.700	141	VIB 8.610	107	VIB 309007-15	125
VIB 5.444-5	15,146,148	VIB 6.701	141	VIB 8.617	169	VIB 309007-20	125
VIB 5.445	166	VIB 6.710	141	VIB 8.618-1,5	151	VIB 321926-2	150
VIB 5.446	166	VIB 6.711	141	VIB 8.618-5	151		
VIB 5.448	181	VIB 6.720	141	VIB 8.619	181		
VIB 5.449-CLD	168	VIB 6.721	141	VIB 8.619-USB	182		
VIB 5.449-ICP	168	VIB 6.722	141	VIB 8.660	64		
VIB 5.731	32	VIB 6.725-100	116	VIB 8.660 HEX	66		

PRÜFTECHNIK  
Condition Monitoring  
Oskar-Messterstr. 19-21  
85737 Ismaning, Germany  
[www.pruftechnik.com](http://www.pruftechnik.com)  
Tel. +49 8999616-0  
Fax +49 8999616-300  
eMail: [info@pruftechnik.com](mailto:info@pruftechnik.com)



Printed in Germany LIT.01.700.11.2014.EN  
VIBXPERT®, VIBREX®, VIBRONET®, VIBCODE®, VIBROTIP®, VIBSCAN-  
NER®, WEARSCANNER®, OMNITREND®, VIBROTECTOR® are trademarks  
of PRÜFTECHNIK Dieter Busch AG. PRÜFTECHNIK products are the sub-  
ject of patents granted and pending throughout the world. Contents  
subject to change without further notice, particularly in the interest of  
further technical development. Reproduction, in any form whatsoever,  
only upon express written consent of PRÜFTECHNIK.  
© Copyright by PRÜFTECHNIK AG

**Productive maintenance technology**